

MAR GREGORIOS COLLEGE OF ARTS & SCIENCE

Block No.8, College Road, Mogappair West, Chennai – 37

Affiliated to the University of Madras
Approved by the Government of Tamil Nadu
An ISO 9001:2015 Certified Institution



DEPARTMENT OF MATHS

SUBJECT NAME: ALLIED MATHEMATICS - II

SUBJECT CODE: SM3AB

SEMESTER: II

PREPARED BY: PROF. S.KAVITHA

UNIVERSITY OF MADRAS
U.G. DEGREE COURSE
SYLLABUS WITH EFFECT FROM 2020-2021

BMA-CSA02

ALLIED MATHEMATICS –II

Credits: 5

Year: I/II, Sem:II/IV

LEARNING OUTCOMES:

- Students gain knowledge about basic concepts of Differential Equations, Laplace Transforms, Vector Analysis and Calculus.

UNIT I

Integral Calculus: Bernoulli's formula – Reduction formulae- $\int_0^{\pi/2} \sin^n x \, dx$, $\int_0^{\pi/2} \cos^n x \, dx$, $\int_0^{\pi/2} \sin^m x \cos^n x \, dx$ (m, n being positive integers), Fourier series for functions in $(0, 2\pi)$, $(-\pi, \pi)$.

Chapter 2: Section 2.7 & 2.9, Chapter 4: Section 4.1.

UNIT II

Differential Equations:

Ordinary Differential Equations: second order non-homogeneous differential equations with constant coefficients of the form $ay'' + by' + cy = X$ where X is of the form $e^{\alpha x} \cos \beta x$ and $e^{\alpha x} \sin \beta x$ -Related problems only.

Partial Differential Equations: Formation, complete integrals and general integrals, four standard types and solving Lagrange's linear equation $Pp + Qq = R$.

Chapter 5: Section 5.2.1, Chapter 6: Section 6.1 to 6.4

UNIT III

Laplace Transforms: Laplace transformations of standard functions and simple properties, inverse Laplace transforms, Application to solution of linear differential equations up to second order- simple problems.

Chapter 7: Section 7.1.1 to 7.1.4 & 7.2 to 7.3

UNIT IV

Vector Differentiation: Introduction, Scalar point functions, Vector point functions, Vector differential operator Gradient, Divergence, Curl, Solenoidal, irrotational, identities.

Chapter 8, Section 8.1 to 8.4.4

UNIT V

Vector Integration: Line, surface and volume integrals, Gauss, Stoke's and Green's theorems (without proofs). Simple problems on these.

Chapter 8, Section 8.5 to 8.6.3.

UNIVERSITY OF MADRAS
U.G. DEGREE COURSE
SYLLABUS WITH EFFECT FROM 2020-2021

Content and treatment as in

Allied Mathematics, Volume I and II, P. Duraipandian and S. Udayabaskaran, S. Chand Publications.

Reference:-

1. S. Narayanan and T.K. Manickavasagam Pillai – Ancillary Mathematics, S. Viswanathan Printers, 1986, Chennai.
2. Allied Mathematics by Dr. A. Singaravelu, Meenakshi Agency.

e-Resources:

1. <http://www.sosmath.com>
2. [http://www.analyzemath.com/Differential Equations/applications.html](http://www.analyzemath.com/Differential_Equations/applications.html)



UNIT-1

INTEGRAL CALCULUS

4.1 Reduction formulae for $\int \sin^n x dx$ and $\int \cos^n x dx$:

$$\text{Let } I_n = \int \sin^n x dx = \int \sin^{n-1} x \sin x dx$$

Integrating by parts by taking $\sin^{n-1} x$ as first function and $\sin x$ as second function.

$$I_n = \sin^{n-1} x (-\cos x) - \int (n-1) \sin^{n-2} x \cdot \cos x (-\cos x) dx$$

$$= -\sin^{n-1} x \cos x + (n-1) \int \sin^{n-2} x \cos^2 x dx$$

$$= -\sin^{n-1} x \cos x + (n-1) \int \sin^{n-2} x (1 - \sin^2 x) dx$$

$$= -\sin^{n-1} x \cos x + (n-1) \int \sin^{n-2} x dx - (n-1) \int \sin^n x dx$$

$$I_n = -\sin^{n-1} x \cos x + (n-1) I_{n-2} - (n-1) I_n$$

$$\Rightarrow I_n + (n-1) I_n = -\sin^{n-1} x \cos x + (n-1) I_{n-2}$$

$$\Rightarrow I_n = \frac{-\sin^{n-1} x \cos x}{n} + \frac{(n-1)}{n} I_{n-2}$$

is the required reduction formula for $\int \sin^n x dx$

$$\text{Similarly } \int \cos^n x dx = \frac{\cos^{n-1} x \sin x}{n} + \frac{(n-1)}{n} I_{n-2}$$

Derivation of formula for $\int_0^{\pi/2} \sin^n x dx$

$$\int \sin^n x dx = -\frac{1}{n} \sin^{n-1} x \cos x + \frac{n-1}{n} I_{n-2} \quad (\text{By reduction formula for } \int \sin^n x dx)$$

$$\begin{aligned} \therefore \int_0^{\pi/2} \sin^n x dx &= -\frac{1}{n} \sin^{n-1} x \cos x \Big|_0^{\pi/2} + \frac{n-1}{n} \int_0^{\pi/2} \sin^{n-2} x dx \\ &= 0 + \frac{n-1}{n} \int_0^{\pi/2} \sin^{n-2} x dx \end{aligned}$$

$$\therefore I_n = \frac{n-1}{n} I_{n-2} \quad (\text{where } I_n = \int_0^{\pi/2} \sin^n x dx)$$

Changing n to $n-2, n-4, n-6, \dots$ in successive steps, we get

$$I_{n-2} = \frac{n-3}{n-2} I_{n-4}$$

$$I_{n-4} = \frac{n-5}{n-4} I_{n-6} \text{ and so on.}$$

$$\therefore I_n = \frac{n-1}{n} \cdot \frac{n-3}{n-2} \cdot \frac{n-5}{n-4} I_{n-6}$$

Case (i) If n is an even positive integer, then

$$I_n = \frac{n-1}{n} \cdot \frac{n-3}{n-2} \cdots \frac{5}{6} \cdot \frac{3}{4} \cdot \frac{1}{2} \int_0^{\pi/2} 1 dx$$

$$\int_0^{\pi/2} \sin^n x \, dx = \frac{n-1}{n} \cdot \frac{n-3}{n-2} \cdots \frac{5}{6} \cdot \frac{3}{4} \cdot \frac{1}{2} \cdot \frac{\pi}{2}, \text{ if } n \text{ is even}$$

Case (ii) If n is an odd positive integer, then

$$\begin{aligned} I_n &= \frac{n-1}{n} \cdot \frac{n-3}{n-2} \cdot \frac{n-5}{n-4} \cdots \frac{4}{5} \cdot \frac{2}{3} \int_0^{\pi/2} \sin x \, dx \\ &= \frac{n-1}{n} \cdot \frac{n-3}{n-2} \cdot \frac{n-5}{n-4} \cdots \frac{4}{5} \cdot \frac{2}{3} \cdot \cos x \Big|_0^{\pi/2} \end{aligned}$$

$$\therefore \int_0^{\pi/2} \sin^n x \, dx = \frac{n-1}{n} \cdot \frac{n-3}{n-2} \cdot \frac{n-5}{n-4} \cdots \frac{4}{5} \cdot \frac{2}{3} \cdot 1, \text{ if } n \text{ is odd}$$

Example 1 Find $I_n = \int_0^{\pi/2} \cos^n x \, dx$

Solution: $I_n = \int_0^{\pi/2} \cos^n(\frac{\pi}{2} - x) \, dx$ ($\because \int_a^b f(x) \, dx = \int_a^b f(a-x) \, dx$, if f is continuous function on $[0, a]$)

$$\begin{aligned} &= \int_0^{\pi/2} \sin^n x \, dx = \frac{n-1}{n} \cdot \frac{n-3}{n-2} \cdot \frac{n-5}{n-4} \cdots \frac{4}{5} \cdot \frac{2}{3} \cdot \frac{\pi}{2} \text{ if } n \text{ is odd} \\ &= \frac{n-1}{n} \cdot \frac{n-3}{n-2} \cdots \frac{5}{8} \cdot \frac{3}{4} \cdot \frac{1}{2} \cdot \frac{\pi}{2} \text{ if } n \text{ is even} \end{aligned}$$

Example 2 Evaluate $\int_0^{\pi/2} \sin^4 x \, dx$

Solution: $\int_0^{\pi/2} \sin^4 x \, dx = \frac{3}{4} \cdot \frac{1}{2} \cdot \frac{\pi}{2} = \frac{3\pi}{16}$

Example 3 Evaluate $\int_0^{\infty} \frac{dx}{(1+x^2)^4}$

Solution: Put $x = \tan t \Rightarrow dx = \sec^2 t \, dt$

When $x \rightarrow 0$, $t \rightarrow 0$ and when $x \rightarrow \infty$, $t \rightarrow \frac{\pi}{2}$

\therefore Given integral becomes

$$\begin{aligned} \int_0^{\pi/2} \frac{\sec^2 t \, dt}{(1+\tan^2 t)^4} &= \int_0^{\pi/2} \frac{\sec^2 t \, dt}{(\sec^2 t)^4} = \int_0^{\pi/2} \frac{\sec^2 t \, dt}{\sec^6 t} \\ &= \int_0^{\pi/2} \frac{1}{\sec^4 t} \, dt = \int_0^{\pi/2} \cos^4 t \, dt \\ &= \frac{3}{4} \cdot \frac{1}{2} \cdot \frac{\pi}{2} = \frac{3\pi}{16} \end{aligned}$$

Example 4 Obtain the reduction formula for $\int \sin^m x \cos^n x \, dx$

Solution: Let $I_{m,n} = \int \sin^m x \cos^n x \, dx$

$$\begin{aligned} &= \int \sin^m x \cos^{n-1} x \cos x \, dx \\ &= \int \cos^{n-1} x (\sin^m x \cos x) \, dx \\ &= \cos^{n-1} x \frac{\sin^{m+1} x}{m+1} - \int (n-1) \cos^{n-2} x (-\sin x) \cdot \frac{\sin^{m+1} x}{m+1} \, dx \end{aligned}$$

$$\begin{aligned}
& \text{(Integrating by parts)} \int \sin^{m+1} x \cos^n x \, dx = \frac{\sin^{m+1} x \cos^n x}{m+1} \\
&= \frac{\sin^{m+1} x \cos^{n-1} x}{m+1} + \frac{n-1}{m+1} \int \cos^{n-2} x \sin^{m+2} x \, dx \\
&= \frac{\sin^{m+1} x \cos^{n-1} x}{m+1} + \frac{n-1}{m+1} \int \cos^{n-2} x \sin^m x \sin^2 x \, dx \\
&= \frac{\sin^{m+1} x \cos^{n-1} x}{m+1} + \frac{n-1}{m+1} \int \cos^{n-2} x \sin^m x (1 - \cos^2 x) \, dx \\
&= \frac{\sin^{m+1} x \cos^{n-1} x}{m+1} + \frac{n-1}{m+1} \int \cos^{n-2} x \sin^m x \, dx - \frac{n-1}{m+1} \int \cos^n x \sin^m x \, dx \\
I_{m,n} &= \frac{\sin^{m+1} x \cos^{n-1} x}{m+1} + \frac{n-1}{m+1} I_{m,n-2} - \frac{n-1}{m+1} I_{m,n} \\
I_{m,n} + \frac{n-1}{m+1} I_{m,n} &= \frac{\sin^{m+1} x \cos^{n-1} x}{m+1} + \frac{n-1}{m+n} I_{m,n-2} \\
\Rightarrow I_{m,n} (m+n) &= \sin^{m+1} x \cos^{n-1} x + (n-1) I_{m,n-2} \\
\Rightarrow I_{m,n} &= \frac{\sin^{m+1} x \cos^{n-1} x}{m+n} + \frac{n-1}{m+n} \int \sin^m x \cos^{n-2} x \, dx \\
\Rightarrow \int \sin^m x \cos^n x \, dx &= \frac{\sin^{m+1} x \cos^{n-1} x}{m+n} + \frac{n-1}{m+n} \int \sin^m x \cos^{n-2} x \, dx
\end{aligned}$$

Example 5 If $U_n = \int_0^{\pi/2} x^n \sin x \, dx$ and $n > 1$ prove that

$$U_n + n(n-1)U_{n-2} = n \int_0^{\pi/2} x^{n-1} \cos x \, dx$$

Solution: $U_n = \int_0^{\pi/2} x^n \sin x \, dx$

$$\begin{aligned}
&= x^n \int \sin x \, dx - \int \frac{d}{dx} (x^n) [\int \sin x \, dx] \, dx \\
&= x^n \cos x - \int_0^{\pi/2} n x^{n-1} x (-\cos x) \, dx \\
&= -\frac{\pi^n}{2} \cos \frac{\pi}{2} - 0 + \int_0^{\pi/2} n x^{n-1} \cos x \, dx \\
&= n \int_0^{\pi/2} x^{n-1} \cos x \, dx \\
&= n [x^{n-1} \sin x]_0^{\pi/2} - \int_0^{\pi/2} (n-1)x^{n-2} \sin x \, dx \\
&= n x^{n-1} \sin x \Big|_0^{\pi/2} - n(n-1) \int_0^{\pi/2} x^{n-2} \sin x \, dx \\
\Rightarrow U_n &= n \frac{\pi^{n-1}}{2} \sin \frac{\pi}{2} - 0 - n(n-1)U_{n-2} \\
\Rightarrow U_n + n(n-1)U_{n-2} &= n \int_0^{\pi/2} x^{n-1} \cos x \, dx
\end{aligned}$$

Example 6 Evaluate $\int_0^{\pi/2} x^4 \sin x \, dx$

Solution: $U_n = \int_0^{\pi/2} x^4 \sin x \, dx$

$$\text{Now } U_n + n(n-1)U_{n-2} - 2U_{n-1} = n \left(\frac{\pi}{2}\right)^{n-1} \dots \dots \dots (1)$$

Putting $n = 4$ in (1), we get

$$U_4 + 4(4-1)U_2 - 2U_3 = 4 \left(\frac{\pi}{2}\right)^{4-1}$$

$$\Rightarrow U_4 + 12U_2 = \frac{\pi^3}{2} \dots \dots \dots (2)$$

Putting $n = 2$ in (1), we get

$$U_2 + 2(2-1)U_0 - 2U_1 = 2 \left(\frac{\pi}{2}\right)^{2-1}$$

$$U_2 + 2U_0 = \pi \dots \dots \dots (3)$$

$$\begin{aligned} \text{Now } U_0 &= \int_0^{\pi/2} x^0 \sin x = \int_0^{\pi/2} \sin x \, dx \\ &= -\cos x \Big|_0^{\pi/2} = -\cos \frac{\pi}{2} + \cos 0 = 1 \end{aligned}$$

Hence equation (3) becomes

$$\begin{aligned} U_2 + 2(1) &= \pi \\ \Rightarrow U_2 &= \pi - 2 \end{aligned}$$

From (2) b

$$\begin{aligned} U_4 + 12(\pi - 2) &= \frac{\pi^3}{2} \\ U_4 &= \frac{\pi^3}{2} - 12\pi + 24 \\ \Rightarrow \int_0^{\pi/2} x^4 \sin x &= \frac{\pi^3}{2} - 12\pi + 24 \end{aligned}$$

Example 7 If $I_{m,n} = \int_0^{\pi/2} \sin^m x \cos^n x$ then prove that

$$I_{m,n} = \frac{m-1}{m+n} \cdot \frac{m-3}{m+n-2} \cdot \frac{m-5}{m+n-4} \dots \dots \dots \frac{2}{3+n} \cdot \frac{1}{1+n}$$

where m is an odd positive integer and n is a positive integer, even or odd.

Solution: $\int \sin^m x \cos^n x \, dx = \int \sin^{m-1} x (\sin x \cos^n x) \, dx$

$$= \frac{-\cos^{n+1} x}{n+1} + \frac{m-1}{n+1} \int \sin^{m-2} x \cos^n x \, dx$$

(Integrating using by parts)

$$= \frac{-\cos^{n+1} x}{n+1} + \frac{m-1}{n+1} \int \sin^{m-2} x \cos^n x \, dx - \frac{m-1}{n+1} \int \sin^{m-2} x \cos^n x \, dx$$

$$\Rightarrow \frac{m-1}{n+1} \int \sin^{m-2} x \cos^n x \, dx = \frac{\cos^{n+1} x \sin^{m-1} x}{n+1} + \frac{m-1}{n+1} \int \sin^{m-2} x \cos^n x \, dx$$

$$\Rightarrow \int \sin^{m-2} x \cos^n x \, dx = -\frac{\cos^{n+1} x \sin^{m-1} x}{n+1} + \frac{m-1}{n+1} \int \sin^{m-2} x \cos^n x \, dx$$

Now $I_{m,n} = \int_0^{\pi/2} \sin^m x \cos^n x dx = \frac{m-1}{m+n} \int_0^{\pi/2} \sin^{m-2} x \cos^n x dx$

$$= \frac{\sin^{m-1} x \cos^{n+1} x}{m+n} \Big|_0^{\pi/2} + \int_0^{\pi/2} \sin^{m-2} x \cos^n x dx$$

$$\Rightarrow \int_0^{\pi/2} \sin^m x \cos^n x dx = \frac{m-1}{m+n} \int_0^{\pi/2} \sin^{m-2} x \cos^n x dx$$

Hence, $I_{m,n} = \frac{m-1}{m+n} I_{m-2,n}$

Replacing m by m - 2, m - 4,3, 2, we obtain

$$I_{m-2,n} = \frac{m-3}{m+n-2} I_{m-4,n}$$

$$I_{m-4,n} = \frac{m-5}{m+n-4} I_{m-6,n}$$

$$I_{3,n} = \frac{2}{3+n} I_{1,n}$$

$$I_{2,n} = \frac{1}{2+n} I_{0,n}$$

From these relations, we obtain

$$I_{m,n} = \begin{cases} \frac{m-1}{m+n} \cdot \frac{m-3}{m+n-2} \cdot \frac{m-5}{m+n-4} \cdots \frac{2}{3+n} I_{1,n}, & \text{if } m \text{ is odd} \\ \frac{m-1}{m+n} \cdot \frac{m-3}{m+n-2} \cdot \frac{m-5}{m+n-4} \cdots \frac{1}{2+n} I_{0,n}, & \text{if } m \text{ is even} \end{cases}$$

Now, we have

$$I_{1,n} = \int_0^{\pi/2} \sin x \cos^n x dx = \frac{\sin^{n+1} x}{n+1} \Big|_0^{\pi/2} = \frac{1}{n+1}$$

$$\text{And } I_{0,n} = \int_0^{\pi/2} \cos^n x dx = \begin{cases} \frac{n-1}{n} \cdot \frac{n-3}{n-2} \cdots \frac{1}{2} \cdot \frac{\pi}{2}, & \text{if } n \text{ is odd} \\ \frac{n-1}{n} \cdot \frac{n-3}{n-2} \cdots \frac{2}{3} \cdot \frac{1}{2}, & \text{if } n \text{ is even} \end{cases}$$

$$\therefore I_{m,n} = \begin{cases} \frac{m-1}{m+n} \cdot \frac{m-3}{m+n-2} \cdots \frac{2}{3+n} \cdot \frac{1}{1+n} & \text{if } m \text{ is odd and } n \text{ may be even or odd} \\ \frac{m-1}{m+n} \cdot \frac{m-3}{m+n-2} \cdots \frac{1}{2+n} \cdot \frac{n-1}{n} \cdot \frac{n-3}{n-2} \cdots \frac{2}{3} & \text{if } m \text{ is even and } n \text{ is odd} \\ \frac{m-1}{m+n} \cdot \frac{m-3}{m+n-2} \cdots \frac{1}{2+n} \cdot \frac{n-1}{n} \cdot \frac{n-3}{n-2} \cdots \frac{1}{2} \cdot \frac{\pi}{2} & \text{if } m \text{ is even \& } n \text{ is even} \end{cases}$$

These formulae can be expressed as a single formula

$$\int_0^{\pi/2} \sin^m x \cos^n x dx = \frac{(n-1)(n-3)\dots(n-1)}{(m+n)(m+n-2)\dots(m+n-1)}$$

to be multiplied by $\frac{\pi}{2}$ when m & n both are even integers.

Example 8 Find $\int_0^{\pi/2} \sin^6 x \cos^5 x dx$

Solution: Here m = 6 and n = 5

$$\int_0^{\pi/2} \sin^6 x \cos^5 x dx = \frac{4 \cdot 2}{(6+5)(6+5-2)} = \frac{8}{693}$$

Example 9 Evaluate $\int_0^{\pi} x \sin^7 x \cos^4 x dx$

Solution: Let $I = \int_0^{\pi} x \sin^7 x \cos^4 x dx$

$$= \int_0^{\pi} (\pi - x) \sin^7 x \cos^4 x dx \quad (\because \int_0^a f(x) dx = \int_0^a f(a-x) dx)$$

$$= \int_0^{\pi} (\pi - x) \sin^7 x \cos^4 x dx$$

$$= \pi \int_0^{\pi} \sin^7 x \cos^4 x dx - \int_0^{\pi} x \sin^7 x \cos^4 x dx$$

$$\Rightarrow 2I = \pi \int_0^{\pi} \sin^7 x \cos^4 x dx$$

$$= 2 \int_0^{\pi/2} \sin^7 x \cos^4 x dx \quad \because \int_0^{2a} f(x) dx = 2 \int_0^a f(x) dx, \text{ if } f(a-x) = f(x)$$

$$\Rightarrow I = \pi \int_0^{\pi/2} \sin^7 x \cos^4 x dx$$

$$= \frac{\pi \cdot 6 \cdot 4 \cdot 2}{(7+4)(6+4-2)(6+4-4)(6+4-6)} = \frac{16\pi}{385}$$

$$\int_0^{\pi/2} \sin^m x \cos^n x dx = \frac{(m-1)(m-3)\dots(m-1)(n-1)(n-3)\dots(n-1)}{(m+n)(m+n-2)(m+n-4)\dots(m+n-1)}$$

Example 10 Evaluate $\int_0^4 x^3 \sqrt{4x - x^2} dx$

$$\begin{aligned} \text{Solution: Let } I &= \int_0^4 x^3 \sqrt{4x - x^2} dx = \int_0^4 x^3 \sqrt{4-x} dx \\ &= \int_0^4 x^3 \sqrt{x} \sqrt{4-x} dx \\ &= \int_0^4 x^{7/2} (4-x)^{1/2} dx \end{aligned}$$

$$\text{Putting } x = 4 \sin^2 t \Rightarrow dx = 8 \sin t \cos t dt$$

$$\text{Hence } I = \int_0^{\pi/2} 4^{7/2} \sin^7 t (4 - 4 \sin^2 t)^{1/2} \cdot 8 \sin t \cos t dt$$

$$= \int_0^{\pi/2} 4^{7/2} 4^{1/2} 8 \sin^7 t (1 - \sin^2 t)^{1/2} \sin t \cos t dt$$

$$= 8 \cdot 4^4 \int_0^{\pi/2} \sin^8 t \cos^2 t dt$$

$$= 8 \cdot 4^4 \frac{(8-1)(8-3)(8-5)(8-7)}{(8+4)(8+4-2)(8+4-4)(8+4-6)} \cdot \frac{\pi}{2} = \frac{8 \cdot 4^4 \cdot 7 \cdot 5 \cdot 3}{2 \cdot 12 \cdot 8 \cdot 6} \pi = 28\pi$$

)2 2

$$\int_0^{\infty} \frac{x^6 - x^2}{(1+x^3)^5} dx$$

Example 11 Evaluate

Solution: Let $I = \int_0^{\infty} \frac{x^6 - x^2}{(1+x^3)^5} dx$

Put $x^3 = \tan^2 t \Rightarrow 3x^2 dx = 2 \tan t \sec^2 t dt$

Then $I = \int_0^{\pi/2} \frac{\tan^4 t \sec^2 t}{(1+\tan^2 t)^5} \cdot \frac{2 \tan t \sec^2 t dt}{3}$

$$= \frac{2}{3} \int_0^{\pi/2} \frac{\tan^5 t \sec^2 t}{(\sec^2 t)^5} dt = \frac{2}{3} \int_0^{\pi/2} \frac{\tan^5 t}{\sec^8 t} dt$$

$$= \frac{2}{3} \int_0^{\pi/2} \sin^5 t \cos^3 t dt = \frac{2}{3} \int_0^{\pi/2} \sin^4 t \cos^2 t \sin t dt$$

$$= \frac{2}{3} \int_0^{\pi/2} \sin^3 t \cos^2 t dt = \frac{2}{3} \int_0^{\pi/2} (\sin^2 t) \sin t \cos^2 t dt$$

$$= \frac{2}{3} \int_0^{\pi/2} (1 - \cos^2 t) \sin t \cos^2 t dt$$

$$= \frac{2}{3} \left[\int_0^{\pi/2} \sin t \cos^2 t dt - \int_0^{\pi/2} \sin t \cos^4 t dt \right]$$

$$= \frac{2}{3} \left[-\frac{\cos^3 t}{3} + \frac{\cos^5 t}{5} \right]_0^{\pi/2} = \frac{2}{3} \left[0 - \left(-\frac{1}{3} + \frac{1}{5} \right) \right] = \frac{2}{3} \left[\frac{1}{3} - \frac{1}{5} \right] = \frac{2}{3} \cdot \frac{2}{15} = \frac{4}{45}$$

Example 12 Evaluate $\int_0^{\pi/2} \sin^5 x dx$

Solution: We know $\int \sin^n x dx = -\frac{\sin^{n-1} x \cos x}{n} + \frac{n-1}{n} \int \sin^{n-2} x dx$

$$\therefore \int_0^{\pi/4} \sin^5 x dx = \left[-\frac{\sin^4 x \cos x}{5} \right]_0^{\pi/4} + \frac{4}{5} \int_0^{\pi/4} \sin^3 x dx$$

$$= -\frac{1}{5} \left[\frac{\sin^4 x \cos x}{\sqrt{2}} \right]_0^{\pi/4} + \frac{4}{5} \int_0^{\pi/4} \sin^2 x dx \dots\dots(1)$$

Now $\int_0^{\pi/4} \sin^3 x dx = \left[-\frac{\sin^2 x \cos x}{3} \right]_0^{\pi/4} + \frac{2}{3} \int_0^{\pi/4} \sin x dx$

$$= -\frac{1}{3} \left[\frac{\sin^2 x \cos x}{\sqrt{2}} \right]_0^{\pi/4} + \frac{2}{3} \left[-\cos x \right]_0^{\pi/4}$$

$$= -\frac{1}{3} \left[\frac{1}{\sqrt{2}} \cdot \frac{1}{\sqrt{2}} \cdot \frac{1}{\sqrt{2}} \right] + \frac{2}{3} \left[-\frac{1}{\sqrt{2}} + 1 \right]$$

$$= -\frac{1}{3 \cdot 2\sqrt{2}} - \frac{2}{3} \left[\frac{1}{\sqrt{2}} - 1 \right]$$

Putting this value in (1), we get

$$\int_0^{\pi/4} \sin^5 x dx = -\frac{1}{5} \left[\frac{1}{\sqrt{2}} \cdot \frac{1}{\sqrt{2}} \cdot \frac{1}{\sqrt{2}} \right] + \frac{4}{5} \left[-\frac{1}{6\sqrt{2}} - \frac{1}{2} \left(\frac{1}{\sqrt{2}} - 1 \right) - 1 \right]$$

$$= \frac{-1}{5 \cdot 4\sqrt{2}} - \frac{4}{5} \left[\frac{1}{6\sqrt{2}} + \frac{1}{2\sqrt{2}} - \frac{1}{2} \right]$$

Example 13 Evaluate $\int_0^1 \frac{x^5}{2\sqrt{1-x^2}} dx$

Solution: Put $x = \sin t \Rightarrow dx = \cos t dt$

Then the given integral becomes

$$\begin{aligned} \frac{1}{2} \int_0^{\pi/2} \frac{\sin^5 t \cos t}{\sqrt{1-\sin^2 t}} dt &= \frac{1}{2} \int_0^{\pi/2} \sin^4 t \cos t dt \\ &= \frac{1}{2} \frac{(5-1)(5-3)}{5(5-2)(5-4)} = \frac{4}{15} \end{aligned}$$

Example 14 Evaluate $\int_{-\pi/2}^{\pi/2} \cos^3 t (1 + \sin t)^2 dt$

Solution: $\int_{-\pi/2}^{\pi/2} \cos^3 t (1 + \sin t)^2 dt = \int_{-\pi/2}^{\pi/2} \cos^3 t (1 + \sin^2 t + 2\sin t) dt$

$$\begin{aligned} &= \int_{-\pi/2}^{\pi/2} \cos^3 t dt + \int_{-\pi/2}^{\pi/2} \cos^3 t \sin^2 t dt + 2 \int_{-\pi/2}^{\pi/2} \cos^3 t \sin t dt \\ &= 2 \int_0^{\pi/2} \cos^3 t dt + 2 \int_0^{\pi/2} \cos^3 t \sin^2 t dt + 0 \\ &= \frac{2 \cdot 2 - 1}{3(3-2)} + 2 \frac{(2-1)(3-1)}{(3+2)(3+2-2) \cdot 2-4} \\ &= \frac{4}{3} + \frac{4}{15} = \frac{8}{5} \end{aligned}$$

Exercise 7A

- Evaluate $\int_0^{2a} x^3 (2ax - x^2)^{3/2} dx$ Ans. $\frac{9\pi a^7}{16}$
- Evaluate $\int_0^{\infty} \frac{x^3}{(1+x^2)^{9/2}} dx$ Ans. $\frac{2}{35}$
- Evaluate $\int_0^{\pi/2} (\cos 2t)^{3/2} \cos t dt$ Ans. $\frac{3\pi}{16\sqrt{2}}$
- Evaluate $\int_0^{\pi/2} \sin^4 x \cos 3x dx$ Ans. $\frac{-13}{35}$
- Evaluate $\int_0^a x^2 \sqrt{ax - x^2} dx$ Ans. $\frac{5\pi a^4}{128}$
- Evaluate $\int_0^{\pi/2} \frac{\cos^2 \theta}{\cos^2 \theta + 4} d\theta$ Ans. $\frac{\pi}{6}$
- Evaluate $\int_0^{\pi} \frac{\sin^4 \theta \sqrt{1-\cos \theta}}{\sin \theta} d\theta$ Ans. $\frac{64\sqrt{2}}{128}$
- Evaluate $\int_0^1 \frac{(1+\cos \theta)^2}{x^{3/2}(1-x)^{3/2}} dx$ Ans. $\frac{3\pi^{15}}{128}$

Fourier Series

PERIODIC FUNCTIONS

If the value of each ordinate $f(t)$ repeats itself at equal intervals in the abscissa, then $f(t)$ is said to be a periodic function.

If $f(t) = f(t + T) = f(t + 2T) = \dots$ then T is called the period of the function $f(t)$.

For example :

$\sin x = \sin(x + 2\pi) = \sin(x + 4\pi) = \dots$ so $\sin x$ is a periodic function with the period 2π . This is also called sinusoidal periodic function.

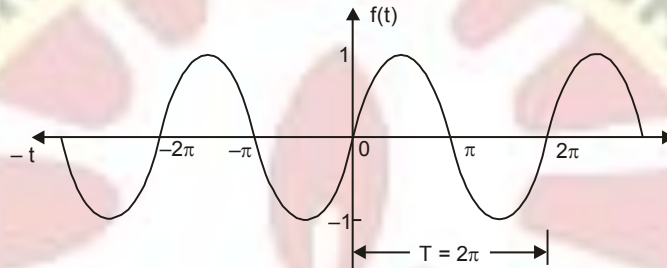

FOURIER SERIES

Here we will express a non-sinusoidal periodic function into a fundamental and its harmonics. A series of sines and cosines of an angle and its multiples of the form.

$$\begin{aligned} & \frac{a_0}{2} + a_1 \cos x + a_2 \cos 2x + a_3 \cos 3x + \dots + a_n \cos nx + \dots \\ & + b_1 \sin x + b_2 \sin 2x + b_3 \sin 3x + \dots + b_n \sin nx + \dots \\ & = \frac{a_0}{2} + \sum_{n=1}^{\infty} a_n \cos nx + \sum_{n=1}^{\infty} b_n \sin nx. \end{aligned}$$

is called the *Fourier series*, where $a_1, a_2, \dots, a_n, \dots, b_1, b_2, b_3, \dots, b_n, \dots$ are constants.

A periodic function $f(x)$ can be expanded in a Fourier Series. The series consists of the following:

- (i) A constant term a_0 (called d.c. component in electrical work).
- (ii) A component at the fundamental frequency determined by the values of a_1, b_1 .
- (iii) Components of the harmonics (multiples of the fundamental frequency) determined by $a_2, a_3, \dots, b_2, b_3, \dots$. And $a_0, a_1, a_2, \dots, b_1, b_2, \dots$ are known as *Fourier coefficients* or Fourier constants.

Fourier Series

DIRICHLET'S CONDITIONS FOR A FOURIER SERIES

If the function $f(x)$ for the interval $(-\pi, \pi)$

- (1) is single-valued
- (2) is bounded
- (3) has at most a finite number of maxima and minima.
- (4) has only a finite number of discontinuities
- (5) is $f(x + 2\pi) = f(x)$ for values of x outside $[-\pi, \pi]$, then

$$S_p(x) = \frac{a_0}{2} + \sum_{n=1}^p a_n \cos nx + \sum_{n=1}^p b_n \sin nx$$

converges to $f(x)$ as $P \rightarrow \infty$ at values of x for which $f(x)$ is continuous and to $\frac{1}{2}[f(x+0) + f(x-0)]$ at points of discontinuity.

ADVANTAGES OF FOURIER SERIES

1. Discontinuous function can be represented by Fourier series. Although derivatives of the discontinuous functions do not exist. (This is not true for Taylor's series).
2. The Fourier series is useful in expanding the periodic functions since outside the closed interval, there exists a periodic extension of the function.
3. Expansion of an oscillating function by Fourier series gives all modes of oscillation (fundamental and all overtones) which is extremely useful in physics.
4. Fourier series of a discontinuous function is not uniformly convergent at all points.
5. Term by term integration of a convergent Fourier series is always valid, and it may be valid if the series is not convergent. However, term by term, differentiation of a Fourier series is not valid in most cases.

USEFUL INTEGRALS

The following integrals are useful in Fourier Series.

$$(i) \int_0^{2\pi} \sin nx \, dx = 0$$

$$(ii) \int_0^{2\pi} \cos nx \, dx = 0$$

$$(iii) \int_0^{2\pi} \sin^2 nx \, dx = \pi$$

$$(iv) \int_0^{2\pi} \cos^2 nx \, dx = \pi$$

$$(v) \int_0^{2\pi} \sin nx \cdot \sin mx \, dx = 0$$

$$(vi) \int_0^{2\pi} \cos nx \cos mx \, dx = 0$$

$$(vii) \int_0^{2\pi} \sin nx \cdot \cos mx \, dx = 0$$

$$(viii) \int_0^{2\pi} \sin nx \cdot \cos nx \, dx = 0$$

$$(ix) \int uv \, dx = uv_1 - u'v_2 + u''v_3 - u'''v_4 + \dots$$

where $v_1 = \int v \, dx$, $v_2 = \int v_1 \, dx$ and so on $u' = \frac{du}{dx}$, $u'' = \frac{d^2u}{dx^2}$ and so on and

$$(x) \sin n\pi = 0, \cos n\pi = (-1)^n \text{ where } n \in I$$

DETERMINATION OF FOURIER COEFFICIENTS (EULER'S FORMULAE)

$$f(x) = \frac{a_0}{2} + a_1 \cos x + a_2 \cos 2x + \dots + a_n \cos nx + \dots$$

$$+ b_1 \sin x + b_2 \sin 2x + \dots + b_n \sin nx + \dots \quad \dots (1)$$

- (i) **To find a_0 :** Integrate both sides of (1) from $x = 0$ to $x = 2\pi$.

Fourier Series

$$\begin{aligned}
 \int_0^{2\pi} f(x) dx &= \frac{a_0}{2} \int_0^{2\pi} dx + a_1 \int_0^{2\pi} \cos x dx + a_2 \int_0^{2\pi} \cos 2x dx + \dots + a_n \int_0^{2\pi} \cos nx dx + \dots \\
 &\quad + b_1 \int_0^{2\pi} \sin x dx + b_2 \int_0^{2\pi} \sin 2x dx + \dots + b_n \int_0^{2\pi} \sin nx dx + \dots \\
 &= \frac{a_0}{2} \int_0^{2\pi} dx, \quad (\text{other integrals} = 0 \text{ by formulae (i) and (ii) of Art. 12.5}) \\
 \int_0^{2\pi} f(x) dx &= \frac{a_0}{2} \cdot 2\pi, \quad \Rightarrow \quad a_0 = \frac{1}{\pi} \int_0^{2\pi} f(x) dx \quad \dots (2)
 \end{aligned}$$

(ii) **To find a_n :** Multiply each side of (1) by $\cos nx$ and integrate from $x = 0$ to $x = 2\pi$.

$$\begin{aligned}
 \int_0^{2\pi} f(x) \cos nx dx &= \frac{a_0}{2} \int_0^{2\pi} \cos nx dx + a_1 \int_0^{2\pi} \cos x \cos nx dx + \dots + a_n \int_0^{2\pi} \cos^2 nx dx + \dots \\
 &\quad + b_1 \int_0^{2\pi} \sin x \cos nx dx + b_2 \int_0^{2\pi} \sin 2x \cos nx dx + \dots \\
 &= a_n \int_0^{2\pi} \cos^2 nx dx = a_n \pi \quad (\text{Other integrals} = 0, \text{ by formulae on Page 851}) \\
 \therefore a_n &= \frac{1}{\pi} \int_0^{2\pi} f(x) \cos nx dx
 \end{aligned}$$

By taking $n = 1, 2, \dots$ we can find the values of a_1, a_2, \dots

(iii) **To find b_n :** Multiply each side of (1) by $\sin nx$ and integrate from $x = 0$ to $x = 2\pi$.

$$\begin{aligned}
 \int_0^{2\pi} f(x) \sin nx dx &= \frac{a_0}{2} \int_0^{2\pi} \sin nx dx + a_1 \int_0^{2\pi} \cos x \sin nx dx + \dots + a_n \int_0^{2\pi} \cos nx \sin nx dx + \dots \\
 &\quad + b_1 \int_0^{2\pi} \sin x \sin nx dx + \dots + b_n \int_0^{2\pi} \sin^2 nx dx + \dots \\
 &= b_n \int_0^{2\pi} \sin^2 nx dx \quad (\text{All other integrals} = 0, \text{ Article No. 12.5}) \\
 \Rightarrow b_n &= \frac{1}{\pi} \int_0^{2\pi} f(x) \sin nx dx \quad \dots (4)
 \end{aligned}$$

Note : To get similar formula of a_n , $\frac{1}{\pi} \int_0^{2\pi} f(x) \cos nx dx$ has been written with a_n in Fourier series.

Example 1. Find the Fourier series representing

$$f(x) = x, \quad 0 < x < 2\pi$$

and sketch its graph from $x = -4\pi$ to $x = 4\pi$.

$$\text{Solution. Let } f(x) = \frac{a_0}{2} + a_1 \cos x + a_2 \cos 2x + \dots + b_1 \sin x + b_2 \sin 2x + \dots \quad \dots (1)$$

Fourier Series
Hence

$$a_0 = \frac{1}{2\pi} \int_{-\pi}^{\pi} f(x) dx = \frac{1}{2\pi} \int_{-\pi}^{\pi} x dx = \frac{1}{2} \left[\frac{x^2}{2} \right]_{-\pi}^{\pi} = 2\pi$$

$$a_n = \frac{1}{\pi} \int_{-\pi}^{\pi} f(x) \cos nx dx = \frac{1}{\pi} \int_{-\pi}^{\pi} x \cos nx dx$$

$$= \frac{1}{\pi} \left[x \frac{\sin nx}{n} - 1 \cdot \left(-\frac{\cos nx}{n^2} \right) \right]_{-\pi}^{\pi} = \frac{1}{\pi} \left[\frac{\cos 2n\pi}{n^2} - \frac{1}{n^2} \right] = \frac{1}{n^2\pi} (1-1) = 0$$

$$b_n = \frac{1}{\pi} \int_{-\pi}^{\pi} f(x) \sin nx dx = \frac{1}{\pi} \int_{-\pi}^{\pi} x \sin nx dx$$

$$= \frac{1}{\pi} \left[x \left(-\frac{\cos nx}{n} \right) - 1 \cdot \left(-\frac{\sin nx}{n^2} \right) \right]_{-\pi}^{\pi} = \frac{1}{\pi} \left[-2\pi \cos 2n\pi \right] = -\frac{2}{n}$$

Substituting the values of a_0, a_n, b_n in (1), we get

$$x = \pi - 2 \left[\sin x + \frac{1}{2} \sin 2x + \frac{1}{3} \sin 3x + \dots \right] \quad \text{Ans.}$$

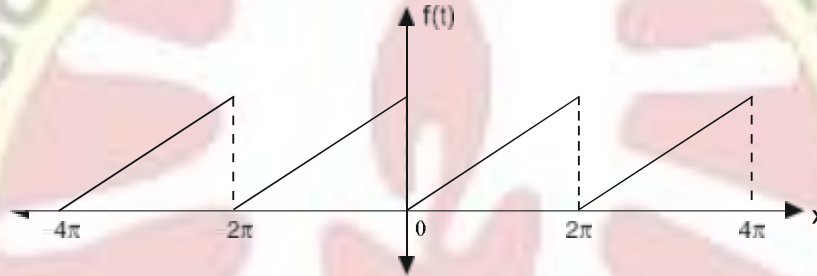

Example 2. Given that $f(x) = x + x^2$ for $-\pi < x < \pi$, find the Fourier expression of $f(x)$.

Deduce that $\frac{\pi^2}{6} = 1 + \frac{1}{2^2} + \frac{1}{3^2} + \frac{1}{4^2} + \dots$ (UP. II Semester; Summer 2003)

Solution. Let $x + x^2 = \frac{a_0}{2} + a_1 \cos x + a_2 \cos 2x + \dots + b_1 \sin x + b_2 \sin 2x + \dots$... (1)

$$a_0 = \frac{1}{\pi} \int_{-\pi}^{\pi} f(x) dx = \frac{1}{\pi} \int_{-\pi}^{\pi} (x + x^2) dx \quad (f(x) = x \text{ odd function})$$

$$= \frac{1}{\pi} \left[\frac{x^2}{2} + \frac{x^3}{3} \right]_{-\pi}^{\pi} = \frac{1}{\pi} \left[\frac{\pi^2}{2} + \frac{\pi^3}{3} - \left(\frac{\pi^2}{2} + \frac{\pi^3}{3} \right) \right] = \frac{2\pi^2}{3}$$

$$a_n = \frac{1}{\pi} \int_{-\pi}^{\pi} f(x) \cos nx dx = \frac{1}{\pi} \int_{-\pi}^{\pi} (x + x^2) \cos nx dx = \frac{2}{\pi} \int_0^{\pi} x^2 \cos nx dx$$

(x cos nx is odd function)

$$= \frac{2}{\pi} \left[x^2 \frac{\sin nx}{n} - (2x) \frac{(-\cos nx)}{n^2} + (2) \left(-\frac{\sin nx}{n^3} \right) \right]_0^{\pi}$$

$$= \frac{2}{\pi} \left[\frac{\pi^2 \sin n\pi}{n} - \frac{2\pi(-\cos n\pi)}{n^2} + \left(-\frac{2 \sin n\pi}{n^3} \right) \right] = \frac{4(-1)^n}{n^2}$$

$$b_n = \frac{1}{\pi} \int_{-\pi}^{\pi} f(x) \sin nx dx = \frac{1}{\pi} \int_{-\pi}^{\pi} (x + x^2) \sin nx dx$$

Fourier Series

$$\begin{aligned}
 &= \frac{2}{\pi} \int_0^{\pi} x \sin nx \, dx && (x^2 \sin nx \text{ is an odd function}) \\
 &= \frac{2}{\pi} \left[(x) \left(-\frac{\cos nx}{n} \right) - (1) \left(-\frac{\sin nx}{n^2} \right) \right]_0^{\pi} = \frac{2}{\pi} \left[-(\pi) \frac{\cos n\pi}{n} + \frac{\sin n\pi}{n^2} \right] \\
 &= \frac{2}{\pi} \left[-\frac{\pi \cos n\pi}{n} \right] = -\frac{2}{\pi} (-1)^n = \frac{2}{\pi} (-1)^{n+1}
 \end{aligned}$$

Substituting the values of a_0, a_n, b_n in (1) we get

$$x + x = \frac{\pi^2}{3} + 4 \left[-\cos x + \frac{1}{2^2} \cos 2x - \frac{1}{3^2} \cos 3x + \dots \right] + 2 \left[\sin x - \frac{1}{2} \sin 2x + \frac{1}{3} \sin 3x - \dots \right] \dots (2)$$

Put $x = \pi$ in (2),

$$\pi + \pi^2 = \frac{\pi^2}{3} + 4 \left[1 + \frac{1}{2^2} + \frac{1}{3^2} + \frac{1}{4^2} + \dots \right] \dots (3)$$

Put $x = -\pi$ in (2), $-\pi + \pi^2 = \frac{\pi^2}{3} + 4 \left[1 + \frac{1}{2^2} + \frac{1}{3^2} + \frac{1}{4^2} + \dots \right] \dots (4)$

Adding (3) and (4)

$$\begin{aligned}
 2\pi^2 &= \frac{2\pi^2}{3} + 8 \left[1 + \frac{1}{2^2} + \frac{1}{3^2} + \frac{1}{4^2} + \dots \right] \\
 \frac{4\pi^2}{3} &= 8 \left[1 + \frac{1}{2^2} + \frac{1}{3^2} + \frac{1}{4^2} + \dots \right] \\
 \frac{\pi^2}{6} &= 1 + \frac{1}{2^2} + \frac{1}{3^2} + \frac{1}{4^2} + \dots = \sum_{n=1}^{\infty} \frac{1}{n^2}
 \end{aligned}$$

Ans.

Exercise 12.1

1. Find a Fourier series to represent, $f(x) = \pi - x$ for $0 < x < 2\pi$.

$$\text{Ans. } 2 \left[\sin x + \frac{1}{2} \sin 2x + \frac{1}{3} \sin 3x + \dots + \frac{1}{n} \sin nx + \dots \right]$$

2. Find a Fourier series to represent $x - x^2$ from $x = -\pi$ to π and show that

$$\frac{\pi^2}{12} = \frac{1}{1^2} - \frac{1}{2^2} + \frac{1}{3^2} - \frac{1}{4^2} + \dots$$

$$\text{Ans. } -\frac{\pi^2}{3} + 4 \left[\frac{\cos x}{1^2} - \frac{\cos 2x}{2^2} + \frac{\cos 3x}{3^2} - \frac{\cos 4x}{4^2} + \dots \right] + 2 \left[\frac{\sin x}{2} - \frac{\sin 2x}{3} + \frac{\sin 3x}{4} - \frac{\sin 4x}{5} + \dots \right]$$

3. Find a Fourier series to represent: $f(x) = x \sin x$, for $0 < x < 2\pi$

$$\text{Ans. } -1 + \pi \sin x - \frac{\cos x + 2}{2} \cos 2x + \frac{\cos 3x + 4}{3} \cos 3x + \frac{\cos 4x + 8}{4} \cos 4x + \dots$$

4. Find a Fourier series to represent the function $f(x) = e^x$, for $-\pi < x < \pi$ and hence derive a series for $\frac{\pi}{\sinh \pi}$.

$$\text{Ans. } \frac{2 \sinh \pi}{\pi} \left[\left(\frac{1}{2 - 1^2 + 1} \cos x + \frac{1}{2^2 + 1} \cos 2x - \frac{1}{3^2 + 1} \cos 3x + \dots \right) \right]$$

$$+ \left[\frac{1}{1^2 + 1} \sin x - \frac{2}{2^2 + 1} \sin 2x + \frac{3}{3^2 + 1} \sin 3x - \dots \right] \text{ and } = 1 + 2 \left[\frac{1}{2} - \frac{1}{5} + \frac{1}{10} - \dots \right]$$

Fourier Series

5. Obtain the Fourier series for $f(x) = e^{-x}$ in the interval $0 \leq x < 2\pi$.

Ans. $\frac{1}{2} + \frac{1}{2} \cos x + \frac{1}{5} \cos 2x + \frac{1}{10} \cos 3x + \frac{1}{\pi^2} \sin x + \frac{1}{5} \sin 2x + \frac{3}{10} \sin 3x + \dots$

6. If $f(x) = \left(\frac{x}{2}\right)^2, 0 < x < 2\pi$, show that $f(x) = \frac{\pi^2}{12} + \sum_{n=1}^{\infty} \frac{\cos nx}{n^2}$

7. Prove that $x^2 = \frac{\pi^2}{3} + 4 \sum_{n=1}^{\infty} (-1)^n \frac{\cos nx}{n^2}, -\pi < x < \pi$

Hence show that (i) $\sum_{n=1}^{\infty} \frac{1}{n^2} = \frac{\pi^2}{6}$ (ii) $\sum_{n=1}^{\infty} \frac{1}{(2n-1)^2} = \frac{\pi^2}{8}$ (iii) $\sum_{n=1}^{\infty} \frac{1}{n^4} = \frac{90}{(3\pi^2 - 6x\pi + 2\pi^2)}$

8. If $f(x)$ is a periodic function defined over a period $(0, 2\pi)$ $f(x) = \frac{3x^2 - 6x\pi + 2\pi^2}{12}$

Prove that $f(x) = \sum_{n=1}^{\infty} \frac{\cos nx}{n^2}$ and hence show that $\frac{\pi^2}{6} = 1 + \frac{1}{2^2} + \frac{1}{3^2} + \dots$

FUNCTION DEFINED IN TWO OR MORE SUB-RANGES

Example 3. Find the Fourier series of the function

$$f(x) = \begin{cases} -1 & \text{for } -\pi < x < -\frac{\pi}{2} \\ 0 & \text{for } -\frac{\pi}{2} < x < \frac{\pi}{2} \\ +1 & \text{for } \frac{\pi}{2} < x < \pi \end{cases}$$

Solution. Let $f(x) = \frac{a_0}{2} + a \cos x + a \cos 2x + \dots + b \sin x + b \sin 2x + \dots$... (1)

$$a = \frac{1}{\pi} \int_{-\pi}^{\pi} f(x) dx = \frac{1}{\pi} \int_{-\pi}^{-\pi/2} (-1) dx + \frac{1}{\pi} \int_{-\pi/2}^{\pi/2} 0 dx + \frac{1}{\pi} \int_{\pi/2}^{\pi} 1 dx$$

$$= \frac{1}{\pi} \left[-x \right]_{-\pi}^{-\pi/2} + \frac{1}{\pi} \left[x \right]_{\pi/2}^{\pi} = \frac{1}{\pi} \left[\pi - \frac{\pi}{2} - \frac{\pi}{2} + \pi \right] = 0$$

$$a = \frac{1}{\pi} \int_{-\pi}^{\pi} f(x) \cos nx dx = \frac{1}{\pi} \int_{-\pi}^{-\pi/2} (-1) \cos nx dx + \frac{1}{\pi} \int_{-\pi/2}^{\pi/2} (0) \cos nx dx + \frac{1}{\pi} \int_{\pi/2}^{\pi} (1) \cos nx dx$$

$$= -\frac{1}{\pi} \left[\frac{\sin nx}{n} \right]_{-\pi}^{-\pi/2} + \frac{1}{\pi} \left[\frac{\sin nx}{n} \right]_{\pi/2}^{\pi} = -\frac{1}{\pi} \left[-\frac{\sin \frac{n\pi}{2}}{n} + \frac{\sin n\pi}{n} \right] + \frac{1}{\pi} \left[\frac{\sin n\pi}{n} - \frac{\sin \frac{n\pi}{2}}{n} \right] = 0$$

$$b_n = \frac{1}{\pi} \int_{-\pi}^{\pi} f(x) \sin nx dx = \frac{1}{\pi} \int_{-\pi}^{-\pi/2} (-1) \sin nx dx + \frac{1}{\pi} \int_{-\pi/2}^{\pi/2} (0) \sin nx dx + \frac{1}{\pi} \int_{\pi/2}^{\pi} (1) \sin nx dx$$

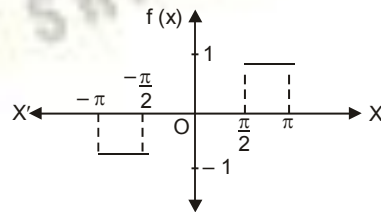

Fourier Series

$$\begin{aligned}
 &= \pi \left[\frac{\cos nx}{n} \right]_{-\pi}^{\pi} - \frac{1}{\pi} \left[\frac{\cos nx}{n} \right]_{-\pi}^{\pi} \\
 &= \frac{2}{n\pi} \left[\cos n\pi - \cos n\pi \right] = \frac{2}{n\pi} \left[\cos n\pi - \cos n\pi \right] \\
 b_1 &= \frac{2}{\pi}, \quad b_2 = -\frac{2}{\pi}, \quad b_3 = \frac{2}{3\pi} \\
 \text{Putting the values of } a_0, a_n, b_n \text{ in (1) we get } f(x) &= \frac{2}{\pi} \sin x - 2 \sin 2x + \frac{2}{3} \sin 3x + \dots
 \end{aligned}$$

Ans.

Example 4. Find the Fourier series for the periodic function

$$f(x) = \begin{cases} 0, & -\pi < x < 0 \\ x, & 0 < x < \pi \end{cases}$$

$$f(x + 2\pi) = f(x)$$

Solution. Let $f(x) = \frac{a_0}{2} + a_1 \cos x + a_2 \cos 2x + \dots + b_1 \sin x + b_2 \sin 2x + \dots$... (1)

$$\begin{aligned}
 a_0 &= \frac{1}{\pi} \int_{-\pi}^{\pi} f(x) dx = \frac{1}{\pi} \int_0^{\pi} x dx = \frac{1}{\pi} \left[\frac{x^2}{2} \right]_0^{\pi} = \frac{\pi^2}{2} \\
 a_n &= \frac{1}{\pi} \int_{-\pi}^{\pi} x \cos nx dx = \frac{1}{\pi} \int_0^{\pi} x \cos nx dx \\
 &= \frac{1}{\pi} \left[\frac{x \sin nx}{n} - \frac{\cos nx}{n^2} \right]_0^{\pi} = \frac{1}{\pi} \left[\frac{\pi \sin n\pi}{n} - \frac{\cos n\pi}{n^2} + \frac{1}{n^2} \right] \\
 &= \frac{1}{\pi} \left[\frac{(-1)^n}{n^2} - \frac{1}{n^2} \right] = -\frac{2}{n^2\pi} \text{ when } n \text{ is odd} \\
 &= 0, \text{ when } n \text{ is even.}
 \end{aligned}$$

$$b_n = \frac{1}{\pi} \int_0^{\pi} x \sin nx dx = \frac{1}{\pi} \left[-\frac{x \cos nx}{n} + \frac{\sin nx}{n^2} \right]_0^{\pi} = \frac{1}{\pi} \left[-\frac{\pi \cos n\pi}{n} + \frac{\sin n\pi}{n^2} \right] = \frac{(-1)^{n+1}}{n}$$

Substituting the values of $a_0, a_1, a_2, \dots, b_1, b_2, \dots$ in (1), we get

$$f(x) = \frac{\pi}{4} - \frac{2}{\pi} \left[\frac{\cos x}{1^2} + \frac{\cos 3x}{3^2} + \frac{\cos 5x}{5^2} + \dots \right] + \left[\frac{\sin x}{1} - \frac{\sin 2x}{2} + \frac{\sin 3x}{3} + \dots \right]$$

Ans.

DISCONTINUOUS FUNCTIONS

At a point of discontinuity, Fourier series gives the value of $f(x)$ as the arithmetic mean of left and right limits.

At the point of discontinuity, $x = c$

$$\text{At } x = c, f(x) = \frac{1}{2} [f(c-0) + f(c+0)]$$

Example 5. Find the Fourier series for $f(x)$, if $f(x) = \begin{cases} -\pi, & -\pi < x < 0 \\ x, & 0 < x < \pi \end{cases}$

Deduce that $\frac{1}{1^2} + \frac{1}{3^2} + \frac{1}{5^2} + \dots = \frac{\pi^2}{8}$

Solution. Let $f(x) = \frac{a_0}{2} + a_1 \cos x + a_2 \cos 2x + \dots + a_n \cos nx + \dots + b_1 \sin x + b_2 \sin 2x + \dots + b_n \sin nx + \dots$... (1)

$$\begin{aligned}
 \text{Then } a_0 &= \frac{1}{\pi} \int_{-\pi}^{\pi} f(x) dx = \frac{1}{\pi} \left[\int_{-\pi}^0 (-\pi) dx + \int_0^{\pi} x dx \right] = \frac{1}{\pi} \left[-\pi(x) \Big|_{-\pi}^0 + \frac{x^2}{2} \Big|_0^{\pi} \right] = \frac{1}{\pi} (-\pi^2 + \frac{\pi^2}{2}) = -\frac{\pi}{2}
 \end{aligned}$$

Fourier Series

$$a = \frac{1}{\pi} \int_{-\pi}^{\pi} f(x) \cos nx \, dx$$

$$a_n = \frac{1}{\pi} \left[\int_{-\pi}^0 (-\pi) \cos nx \, dx + \int_0^{\pi} x \cos nx \, dx \right] = \frac{1}{\pi} \left[-\pi \left(\frac{\sin nx}{n} \right) \Big|_{-\pi}^0 + \left(\frac{x \sin nx}{n} + \frac{\cos nx}{n^2} \right) \Big|_0^{\pi} \right]$$

$$= \frac{1}{\pi} \left[0 + \frac{1}{n^2} \cos n\pi - \frac{1}{n^2} \right] = \frac{1}{\pi n^2} (\cos n\pi - 1) = \frac{1}{n^2 \pi} [(-1)^n - 1] = \frac{-2}{n^2 \pi} \text{ when } n \text{ is odd}$$

$$b_n = \frac{1}{\pi} \left[\int_{-\pi}^0 (-\pi) \sin nx \, dx + \int_0^{\pi} x \sin nx \, dx \right] = \frac{1}{\pi} \left[\frac{\pi \cos nx}{n} \Big|_{-\pi}^0 + \left(-x \frac{\cos nx}{n} + \frac{\sin nx}{n^2} \right) \Big|_0^{\pi} \right]$$

$$= \frac{1}{\pi} \left[\frac{\pi}{n} (1 - \cos n\pi) - \frac{\pi \cos n\pi}{n} \right] = \frac{1}{n} (1 - 2 \cos n\pi) = \frac{1}{n} (1 - 2(-1)^n)$$

$$b_n = \frac{3}{n} \text{ when } n \text{ is odd}$$

$$= \frac{-1}{n} \text{ when } n \text{ is even}$$

$$f(x) = \frac{\pi}{4} - \frac{2}{\pi} \left(\frac{\cos 3x}{3^2} + \frac{\cos 5x}{5^2} + \dots \right) + 3 \sin x - \frac{\sin 2x}{2} + \frac{3 \sin 3x}{3} - \frac{\sin 4x}{4} + \dots \quad \dots (2)$$

Putting $x = 0$ in (2), we get $f(0) = -\frac{\pi}{4} - \frac{2}{\pi} \left(1 + \frac{1}{3^2} + \frac{1}{5^2} + \dots \infty \right)$... (3)

Now $f(x)$ is discontinuous at $x = 0$.
 But $f(0-0) = -\pi$ and $f(0+0) = 0$

$$\therefore f(0) = \frac{1}{2} [f(0-0) + f(0+0)] = -\pi/2$$

$$\text{From (3), } -\frac{\pi}{2} = -\frac{\pi}{4} - \frac{2}{\pi} \left[1 + \frac{1}{3^2} + \frac{1}{5^2} + \dots \right]$$

$$\text{or } \frac{\pi^2}{8} = \frac{1}{1^2} + \frac{1}{3^2} + \frac{1}{5^2} + \dots$$

Proved.

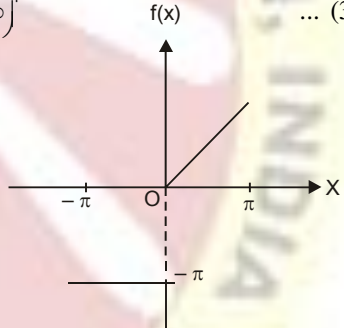

Example 6. Find the Fourier series expansion of the periodic function of period 2π , defined by

$$f(x) = \begin{cases} x & \text{if } -\frac{\pi}{2} < x < \frac{\pi}{2} \\ \pi - x & \text{if } \frac{\pi}{2} < x < \frac{3\pi}{2} \end{cases}$$

Solution. Let $f(x) = \frac{a_0}{2} + a_1 \cos x + a_2 \cos 2x + \dots + b_1 \sin x + b_2 \sin 2x + \dots$

$$\text{Now } a_0 = \frac{1}{\pi} \int_{-\pi/2}^{\pi/2} x \, dx + \frac{1}{\pi} \int_{\pi/2}^{3\pi/2} (\pi - x) \, dx = \frac{1}{\pi} \left(\frac{x^2}{2} \right) \Big|_{-\pi/2}^{\pi/2} + \frac{1}{\pi} \left(\pi x - \frac{x^2}{2} \right) \Big|_{\pi/2}^{3\pi/2}$$

$$= \frac{1}{\pi} \left(\frac{\pi^2}{8} - \frac{\pi^2}{8} \right) + \frac{1}{\pi} \left(\frac{3\pi^2}{2} - \frac{9\pi^2}{8} - \frac{\pi^2}{2} + \frac{\pi^2}{8} \right) = \frac{\pi}{\pi} \left(\frac{3}{2} - \frac{9}{8} - \frac{1}{2} + \frac{1}{8} \right) = 0$$

$$\begin{aligned}
 a_n &= \frac{1}{\pi} \int_{-\pi/2}^{\pi/2} x \cos nx dx + \frac{1}{\pi} \int_{\pi/2}^{3\pi/2} (\pi-x) \cos nx dx \\
 &= \frac{1}{\pi} \left[x \frac{\sin nx}{n} - (1) \left(-\frac{\cos nx}{n^2} \right) \right]_{-\pi/2}^{\pi/2} + \frac{1}{\pi} \left[(\pi-x) \frac{\sin nx}{n} - (-1) \left(-\frac{\cos nx}{n^2} \right) \right]_{\pi/2}^{3\pi/2} \\
 &= \frac{1}{\pi} \left[\frac{\pi \sin \frac{n\pi}{2}}{2} + \frac{\cos \frac{n\pi}{2}}{n^2} - \frac{\pi \sin \frac{n\pi}{2}}{2} - \frac{\cos \frac{n\pi}{2}}{n^2} \right] \\
 &\quad + \frac{1}{\pi} \left[-\frac{\pi \sin \frac{3n\pi}{2}}{2} + \frac{\cos \frac{3n\pi}{2}}{n^2} - \frac{\pi \sin \frac{n\pi}{2}}{2} + \frac{\cos \frac{n\pi}{2}}{n^2} \right] \\
 &= \frac{1}{\pi} \left[-\frac{2\pi}{n} \left(\sin \frac{3n\pi}{2} + \sin \frac{n\pi}{2} \right) - \frac{1}{n^2} \left(\cos \frac{3n\pi}{2} - \cos \frac{n\pi}{2} \right) \right] \\
 &= \frac{1}{\pi} \left[-\frac{\pi}{n} \sin n\pi \cos \frac{n\pi}{2} + \frac{2}{n^2} \sin \frac{n\pi}{2} \sin n\pi \right] = 0 \\
 b_n &= \frac{1}{\pi} \int_{-\pi/2}^{\pi/2} x \sin nx dx + \frac{1}{\pi} \int_{\pi/2}^{3\pi/2} (\pi-x) \sin nx dx = \frac{1}{\pi} \int_0^{\pi/2} x \sin nx dx + \frac{1}{\pi} \int_{\pi/2}^{3\pi/2} (\pi-x) \sin nx dx \\
 &= \frac{2}{\pi} \left[x \left(-\frac{\cos nx}{n} \right) - (1) \left(-\frac{\sin nx}{n^2} \right) \right]_0^{\pi/2} + \frac{1}{\pi} \left[(\pi-x) \left(-\frac{\cos nx}{n} \right) - (-1) \left(-\frac{\sin nx}{n^2} \right) \right]_{\pi/2}^{3\pi/2} \\
 &= \frac{2}{\pi} \left[-\frac{\pi \cos \frac{n\pi}{2}}{2} + \frac{\sin \frac{n\pi}{2}}{n^2} \right] + \frac{1}{\pi} \left[\frac{\pi \cos \frac{3n\pi}{2}}{2} - \frac{\sin \frac{3n\pi}{2}}{n^2} + \frac{\pi \cos \frac{n\pi}{2}}{2} + \frac{\sin \frac{n\pi}{2}}{n^2} \right] \\
 &= \frac{1}{\pi} \left[-\frac{\pi \cos \frac{n\pi}{2}}{2} + \frac{3 \sin \frac{n\pi}{2}}{n^2} + \frac{\pi \cos \frac{3n\pi}{2}}{2} - \frac{\sin \frac{3n\pi}{2}}{n^2} \right] \\
 &= \frac{1}{\pi} \left[\frac{2\pi}{n} \left(\cos \frac{3n\pi}{2} - \cos \frac{n\pi}{2} \right) + \frac{3}{n^2} \sin \frac{n\pi}{2} - \frac{1}{n^2} \sin \frac{3n\pi}{2} \right] \\
 &= \frac{1}{\pi} \left[-\frac{\pi}{n} \sin n\pi \sin \frac{n\pi}{2} + \frac{3}{n^2} \sin \frac{n\pi}{2} - \frac{1}{n^2} \sin \frac{3n\pi}{2} \right] = \frac{1}{\pi} \left[\frac{3 \sin \frac{n\pi}{2} - \sin \frac{3n\pi}{2}}{n^2} \right]
 \end{aligned}$$

Substituting the values of $a_n, a_1, a_2, \dots, b_1, b_2, \dots$ we get $f(x) = \frac{4}{\pi} \left[\frac{\sin x}{1^2} - \frac{\sin 3x}{3^2} + \frac{\sin 5x}{5^2} - \dots \right]$ **Ans.**

Example 7. Find the Fourier series of the function defined as $f(x) = \begin{cases} x & \text{for } 0 < x < \pi \\ -x - \pi & \text{for } -\pi < x < 0 \end{cases}$ and $f(x+2\pi) = f(x)$.

Solution.

$$\begin{aligned}
 a_n &= \frac{1}{\pi} \int_{-\pi}^{\pi} f(x) dx = \frac{1}{\pi} \int_{-\pi}^0 f(x) dx + \frac{1}{\pi} \int_0^{\pi} f(x) dx \\
 &= \frac{1}{\pi} \int_{-\pi}^0 (-x - \pi) dx + \frac{1}{\pi} \int_0^{\pi} (x) dx = \frac{1}{\pi} \left[-\frac{x^2}{2} - \pi x \right]_{-\pi}^0 + \frac{1}{\pi} \left[\frac{x^2}{2} \right]_0^{\pi} \\
 &= \frac{1}{\pi} \left[0 - \left(-\frac{\pi^2}{2} - \pi^2 \right) \right] + \frac{1}{\pi} \left[\frac{\pi^2}{2} - 0 \right] = \frac{1}{\pi} \left[\frac{\pi^2}{2} + \pi^2 \right] + \frac{1}{\pi} \left[\frac{\pi^2}{2} \right] = \frac{3\pi}{2}
 \end{aligned}$$

Fourier Series

$$\begin{aligned}
 a_n &= \frac{1}{\pi} \int_{-\pi}^{\pi} f(x) \cos nx \, dx = \frac{1}{\pi} \int_0^{\pi} f(x) \cos nx \, dx + \frac{1}{\pi} \int_{-\pi}^0 f(x) \cos nx \, dx \\
 &= \frac{1}{\pi} \int_0^{\pi} (-x - \pi) \cos nx \, dx + \frac{1}{\pi} \int_0^{\pi} (x + \pi) \cos nx \, dx \\
 &= \frac{1}{\pi} \left[(-x - \pi) \frac{\sin nx}{n} - (-1) \left\{ \frac{\cos nx}{n^2} \right\} \right]_0^{\pi} + \frac{1}{\pi} \left[(x + \pi) \frac{\sin nx}{n} - (-1) \left\{ \frac{\cos nx}{n^2} \right\} \right]_0^{\pi} \\
 &= \frac{1}{\pi} \left[-\frac{1}{n^2} + \frac{(-1)^n}{n^2} \right] + \frac{1}{\pi} \left[\frac{(-1)^n}{n^2} - \frac{1}{n^2} \right] = \frac{2}{n^2 \pi} [(-1)^n - 1]
 \end{aligned}$$

$$a_n = \frac{-4}{n^2 \pi}, \quad \text{If } n \text{ is odd.}$$

$$\text{and } a_n = 0 \quad \text{if } n \text{ is even.}$$

$$\begin{aligned}
 b_n &= \frac{1}{\pi} \int_{-\pi}^{\pi} f(x) \sin nx \, dx = \frac{1}{\pi} \int_0^{\pi} f(x) \sin nx \, dx + \frac{1}{\pi} \int_{-\pi}^0 f(x) \sin nx \, dx \\
 &= \frac{1}{\pi} \int_0^{\pi} (-x - \pi) \sin nx \, dx + \frac{1}{\pi} \int_0^{\pi} (x + \pi) \sin nx \, dx \\
 &= \frac{1}{\pi} \left[(-x - \pi) \left(-\frac{\cos nx}{n} \right) - (-1) \left(\frac{\sin nx}{n^2} \right) \right]_0^{\pi} + \frac{1}{\pi} \left[(x + \pi) \left(-\frac{\cos nx}{n} \right) - (-1) \left(\frac{\sin nx}{n^2} \right) \right]_0^{\pi} \\
 &= \frac{1}{\pi} \left[\pi + \frac{2\pi}{n} (-1)^n + \frac{\pi}{n} \right] = \frac{1}{\pi} [(1) - 2(-1)^n + (1)] = \frac{2}{\pi} [1 - (-1)^n] \\
 &= \frac{4}{\pi n}, \quad \text{if } n \text{ is odd.} \\
 &= 0, \quad \text{if } n \text{ is even.}
 \end{aligned}$$

$$\begin{aligned}
 \text{Fourier series is } f(x) &= \frac{a_0}{2} + a_1 \cos x + a_2 \cos 2x + \dots + b_1 \sin x + b_2 \sin 2x + \dots \\
 f(x) &= \frac{2}{\pi} \left(\cos x - \cos 3x + \dots \right) + \left(\sin x - \sin 3x + \dots \right) \\
 &= \frac{2}{\pi} \left(\frac{1^2}{1} - \frac{3^2}{3} + \dots \right) + 4 \left(\frac{1}{1} - \frac{3}{3} + \dots \right)
 \end{aligned}$$

Ans.

Exercise 12.2

1. Find the Fourier series of the function

$$f(x) = \begin{cases} -1 & \text{for } -\pi < x < 0 \\ 1 & \text{for } 0 < x < \pi \end{cases}$$

$$\text{where } f(x + 2\pi) = f(x). \quad \text{Ans. } \frac{4}{\pi} \left[\frac{1}{1} \sin x + \frac{1}{3} \sin 3x + \frac{1}{5} \sin 5x + \frac{1}{7} \sin 7x + \dots \right]$$

2. Find the Fourier series for the function

$$f(x) = \begin{cases} -\frac{\pi}{4} & \text{for } -\pi < x < 0 \\ \frac{\pi}{4} & \text{for } 0 < x < \pi \end{cases}$$

$$\text{and } f(-\pi) = f(0) = f(\pi) = 0, \quad f(x) = f(x + 2\pi) \text{ for all } x.$$

$$\text{Deduce that } \frac{\pi}{4} = 1 - \frac{1}{3} + \frac{1}{5} - \frac{1}{7} + \dots \quad \text{Ans. } \frac{\sin x}{1} + \frac{\sin 3x}{3} + \frac{\sin 5x}{5} + \frac{\sin 7x}{7} + \dots$$

3. Find the Fourier series of the function

$$f(x) = \begin{cases} 0 & \text{for } -\pi \leq x \leq 0 \\ 1 & \text{for } 0 < x < \frac{\pi}{2} \\ 0 & \text{for } \frac{\pi}{2} \leq x \leq \pi \end{cases}$$

4. Obtain a Fourier series to represent the following periodic function

$$f(x) = 0 \text{ when } 0 < x < \pi$$

$$f(x) = 1 \text{ when } \pi < x < 2\pi$$

$$\text{Ans. } \frac{1}{2} - \frac{1}{\pi} \left(\frac{1}{3} \sin x + \frac{1}{5} \sin 3x + \frac{1}{7} \sin 5x + \dots \right)$$

5. Find the Fourier expansion of the function defined in a single period by the relations.

$$f(x) = \begin{cases} 1 & \text{for } 0 < x < \pi \\ 2 & \text{for } \pi < x < 2\pi \end{cases}$$

$$\text{and from it deduce that } \frac{\pi}{4} = 1 - \frac{1}{3} + \frac{1}{5} - \frac{1}{7} + \dots$$

$$\text{Ans. } \frac{1}{2} - \frac{1}{\pi} \left(\frac{1}{3} \sin x + \frac{1}{5} \sin 3x + \frac{1}{7} \sin 5x + \dots \right)$$

6. Find a Fourier series to represent the function

$$f(x) = \begin{cases} 0 & \text{for } -\pi < x \leq 0 \\ \frac{1}{4}\pi x & \text{for } 0 < x < \pi \end{cases}$$

$$\text{and hence deduce that } \frac{\pi^2}{8} = \frac{1}{1^2} + \frac{1}{3^2} + \frac{1}{5^2} + \dots$$

$$\text{Ans. } \frac{\pi^2}{16} + \sum_{n=1}^{\infty} \left[\frac{(-1)^n - 1}{4n} \cos nx - \frac{(-1)^n \pi}{4n} \sin nx + \dots \right]$$

7. Find the Fourier series for $f(x)$, if

$$f(x) = -\pi \text{ for } -\pi < x \leq 0$$

$$= x \text{ for } 0 < x < \pi$$

$$= \frac{-\pi}{2} \text{ for } x = 0$$

$$\text{Deducethat } \frac{1}{1^2} + \frac{1}{3^2} + \frac{1}{5^2} + \dots = \frac{\pi^2}{8}$$

$$\text{Ans. } -\frac{\pi}{4} - \frac{1}{\pi} \left(\frac{1}{3^2} \cos x + \frac{1}{5^2} \cos 3x + \frac{1}{7^2} \cos 5x + \dots \right) + 3 \sin x - \frac{1}{2} \sin 2x + \frac{3}{3} \sin 3x - \frac{1}{4} \sin 4x + \dots$$

8. Obtain a Fourier series to represent the function

$$f(x) = |x| \text{ for } -\pi < x < \pi$$

$$\text{and hence deduce } \frac{\pi^2}{8} = \frac{1}{1^2} + \frac{1}{3^2} + \frac{1}{5^2} + \dots$$

$$\text{Ans. } \frac{\pi}{2} - \frac{4}{\pi} \left[\frac{1}{3^2} \cos x + \frac{1}{5^2} \cos 3x + \frac{1}{7^2} \cos 5x + \dots \right]$$

Fourier Series

9. Expand as a Fourier series, the function $f(x)$ defined as

$$f(x) = \begin{cases} \pi + x & \text{for } -\pi < x < -\frac{\pi}{2} \\ \frac{\pi}{2} & \text{for } -\frac{\pi}{2} < x < \frac{\pi}{2} \\ \pi - x & \text{for } \frac{\pi}{2} < x < \pi \end{cases}$$

Ans. $\frac{3\pi}{8} + \frac{2}{\pi} \left[\frac{1}{1^2} \cos x - \frac{2}{2^2} \cos 2x + \frac{1}{3^2} \cos 3x + \dots \right]$

10. Obtain a Fourier series to represent the function

$$f(x) = |\sin x| \text{ for } -\pi < x < \pi \quad \left\{ \begin{array}{l} \text{Hint } f(x) = -\sin x \text{ for } -\pi < x < 0 \\ = \sin x \text{ for } 0 < x < \pi \end{array} \right\}$$

Ans. $\frac{2}{\pi} - \frac{4}{\pi} \left[\frac{1}{3} \cos 2x + \frac{1}{15} \cos 4x + \frac{1}{35} \cos 6x + \dots \right]$

11.

An alternating current after passing through a rectifier has the form

$$i = I \sin \theta \text{ for } 0 < \theta < \pi \\ = 0 \text{ for } \pi < \theta < 2\pi$$

Find the Fourier series of the function.

Ans. $\frac{I}{\pi} - \frac{2I}{\pi} \left(\frac{\cos 2\theta}{3} + \frac{\cos 4\theta}{15} + \dots \right) + \frac{I}{2} \sin \theta$

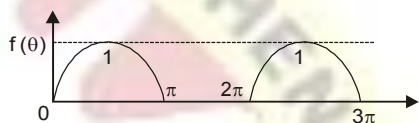

12. If $f(x) = 0$ for $-\pi < x < 0$
 $= \sin x$ for $0 < x < \pi$

Prove that $f(x) = \frac{1}{\pi} + \frac{1}{2} - \sum_{m=1}^{\infty} \frac{\cos 2mx}{4m^2 - 1}$.

Hence show that $\frac{1}{1.3} - \frac{1}{3.5} + \frac{1}{5.7} \dots \infty = \frac{1}{4}(\pi - 2)$

12.8(a) EVEN FUNCTION

A function $f(x)$ is said to be even (or symmetric) function if, $f(-x) = f(x)$

The graph of such a function is symmetric with respect to y-axis [$f(x)$ axis]. Here y-axis is a mirror for the reflection of the curve.

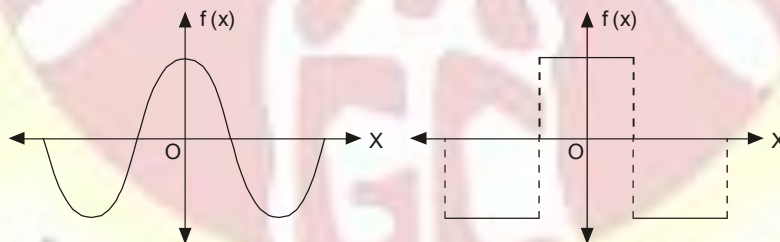

The area under such a curve from $-\pi$ to π is double the area from 0 to π .

$$\therefore \int_{-\pi}^{\pi} f(x) dx = 2 \int_0^{\pi} f(x) dx$$

(b) Odd Function

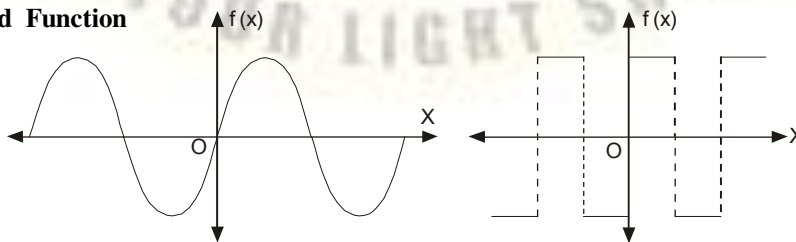

A function $f(x)$ is called odd (or skew symmetric) function if

$$f(-x) = -f(x)$$

Here the area under the curve from $-\pi$ to π is zero.

$$\int_{-\pi}^{\pi} f(x) dx = 0$$

Expansion of an even function:

$$\begin{aligned} a_0 &= \frac{1}{\pi} \int_{-\pi}^{\pi} f(x) dx = \frac{2}{\pi} \int_0^{\pi} f(x) dx \\ a_n &= \frac{1}{\pi} \int_{-\pi}^{\pi} f(x) \cos nx dx = \frac{2}{\pi} \int_0^{\pi} f(x) \cos nx dx \end{aligned}$$

As $f(x)$ and $\cos nx$ are both even functions.

\therefore The product of $f(x) \cdot \cos nx$ is also an even function. page 846

$$b_n = \frac{1}{\pi} \int_{-\pi}^{\pi} f(x) \sin nx dx = 0$$

As $\sin nx$ is an odd function so $f(x) \cdot \sin nx$ is also an odd function. We need not to calculate b_n . It saves our labour a lot.

The series of the even function will contain only cosine terms.

Expansion of an odd function :

$$\begin{aligned} a_0 &= \frac{1}{\pi} \int_{-\pi}^{\pi} f(x) dx = 0 \\ a_n &= \frac{1}{\pi} \int_{-\pi}^{\pi} f(x) \cos nx dx = 0 \quad [f(x) \cdot \cos nx \text{ is odd function.}] \\ b_n &= \frac{1}{\pi} \int_{-\pi}^{\pi} f(x) \sin nx dx = \frac{2}{\pi} \int_0^{\pi} f(x) \sin nx dx \\ &\quad [f(x) \cdot \sin nx \text{ is even function.}] \end{aligned}$$

The series of the odd function will contain only sine terms.

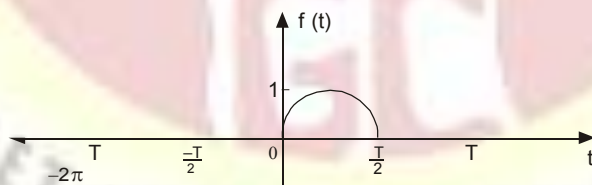

The function shown below is neither odd nor even so it contains both sine and cosine terms

Example 8. Find the Fourier series expansion of the periodic function of period 2π

$$f(x) = x^2, \quad -\pi \leq x \leq \pi$$

Hence, find the sum of the series $\frac{1}{1^2} - \frac{1}{2^2} + \frac{1}{3^2} - \frac{1}{4^2} + \dots$

Solution.

$$f(x) = x^2, \quad -\pi \leq x \leq \pi$$

Fourier Series

This is an even function. $\therefore b_n = 0$

$$a_0 = \frac{2}{\pi} \int_0^{\pi} f(x) dx = \frac{2}{\pi} \int_0^{\pi} x^2 dx = \frac{2}{\pi} \left[\frac{x^3}{3} \right]_0^{\pi} = \frac{2\pi^2}{3}$$

$$a_n = \frac{2}{\pi} \int_0^{\pi} f(x) \cos nx dx = \frac{2}{\pi} \int_0^{\pi} x^2 \cos nx dx$$

$$= \frac{2}{\pi} \left[x^2 \left(\frac{\sin nx}{n} \right) - (2x) \left(\frac{\cos nx}{n} \right) + (2) \left(\frac{\sin nx}{n} \right) \right]_0^{\pi}$$

$$= \frac{2}{\pi} \left[\frac{\pi^2 \sin n\pi}{n} + \frac{2\pi \cos n\pi}{n} - \frac{2 \sin n\pi}{n} \right] = \frac{4(-1)^n}{n^3}$$

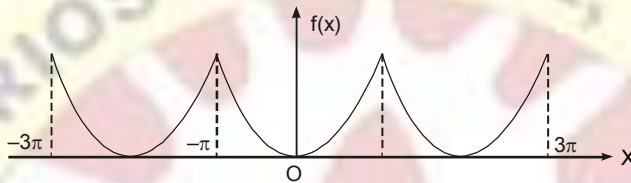

Fourier series is $f(x) = \frac{a_0}{2} + a_1 \cos x + a_2 \cos 2x + a_3 \cos 3x + \dots + a_n \cos nx + \dots$

$$x^2 = \frac{\pi^2}{3} - 4 \left[\frac{\cos x}{1^2} - \frac{\cos 2x}{2^2} + \frac{\cos 3x}{3^3} - \frac{\cos 4x}{4^2} + \dots \right]$$

On putting $x = 0$, we have

$$0 = \frac{\pi^2}{3} - 4 \left[\frac{1}{1^2} - \frac{1}{2^2} + \frac{1}{3^2} - \frac{1}{4^2} \dots \right]$$

$$\frac{1}{1^2} - \frac{1}{2^2} + \frac{1}{3^2} - \frac{1}{4^2} \dots = \frac{\pi^2}{12}$$

Ans.

Example 9. Obtain a Fourier expression for

$$f(x) = x^3 \text{ for } -\pi < x < \pi.$$

Solution. $f(x) = x^3$ is an odd function.

$$\therefore a_0 = 0 \text{ and } a_n = 0$$

$$b_n = \frac{2}{\pi} \int_0^{\pi} f(x) \sin nx dx = \frac{2}{\pi} \int_0^{\pi} x^3 \sin nx dx$$

$$= \frac{2}{\pi} \int_0^{\pi} \left[uv = uv - u'v + u''v - u'''v + \dots \right]$$

$$= \frac{2}{\pi} \left[x^3 \left(\frac{\cos nx}{n} \right) - 3x^2 \left(\frac{\sin nx}{n} \right) + 6x \left(\frac{\cos nx}{n} \right) - 6 \left(\frac{\sin nx}{n} \right) \right]_0^{\pi}$$

$$= \frac{2}{\pi} \left[\frac{-\pi^3 \cos n\pi}{n} + \frac{6\pi \cos n\pi}{n^3} \right] = 2(-1)^n \left[\frac{\pi^2}{n} + \frac{6}{n^3} \right]$$

$$\therefore x^3 = 2 \left[\left(\frac{\pi^2}{1} + \frac{6}{1^3} \right) \sin x + \left(\frac{\pi^2}{2} + \frac{6}{2^3} \right) \sin 2x - \left(\frac{\pi^2}{3} + \frac{6}{3^3} \right) \sin 3x \dots \right]$$

Ans.

UNIT-2

IIII Differential Equations

PARTIAL DIFFERENTIAL EQUATIONS are those equations which contain partial differential coefficients, independent variables and dependent variables.

The independent variables will be denoted by x and y and the dependent variable by z . The partial differential coefficients are denoted as follows:

$$\frac{\partial z}{\partial x} = p, \quad \frac{\partial z}{\partial y} = q,$$

$$\frac{\partial^2 z}{\partial x^2} = r, \quad \frac{\partial^2 z}{\partial x \partial y} = s, \quad \frac{\partial^2 z}{\partial y^2} = t$$

ORDER of a partial differential equation is the same as that of the order of the highest differential coefficient in it.

CLASSIFICATION

Consider the equation. $A \frac{\partial^2 u}{\partial x^2} + B \frac{\partial^2 u}{\partial x \partial y} + C \frac{\partial^2 u}{\partial y^2} + F(x, y, u, p, q) = 0$... (1)

Where A, B, C may be constants or functions of x and y . Now the equation (1) is

1. Parabolic; if $B^2 - 4AC = 0$
2. Elliptic; if $B^2 - 4AC < 0$
3. Hyperbolic; if $B^2 - 4AC > 0$

METHOD OF FORMING PARTIAL DIFFERENTIAL EQUATIONS

A partial differential equation is formed by two methods.

- (i) By eliminating arbitrary constants.
- (ii) By eliminating arbitrary functions.

(i) Method of elimination of arbitrary constants

Example 1. Form a partial differential equation from

$$x^2 + y^2 + (z - c)^2 = a^2.$$

Solution. $x^2 + y^2 + (z - c)^2 = a^2$... (1)

(1) contains two arbitrary constants a and c .

Differentiating (1) partially w.r.t. x we get

$$2x + 2(z - c) \frac{\partial z}{\partial x} = 0$$

$\Rightarrow x + (z - c) p = 0$... (2)

Differentiating (1) partially w.r.t. y we get

$$2y + 2(z - c) \frac{\partial z}{\partial y} = 0$$

LET YOUR LIGHT SHINE

Partial Differential Equations

$$y + (z - c) q = 0 \quad \dots(3)$$

Let us eliminate c from (2) and (3)

$$\text{From (2)} \quad (z - c) = -\frac{x}{p}$$

$$\text{Putting this value of } z - c \text{ in (3), we get } y - \frac{x}{p} q = 0$$

$$\text{or} \quad yp - xq = 0 \quad \text{Ans.}$$

(ii) Method of elimination of arbitrary functions

Example 2. Form the partial differential equation from

$$z = f(x^2 - y^2) \quad \dots (1)$$

Solution.

$$z = f(x^2 - y^2) \quad \dots (1)$$

Differentiating (1) w.r.t x and y

$$P = \frac{\partial z}{\partial x} = f'(x^2 - y^2) 2x \quad \dots(2)$$

$$q = \frac{\partial z}{\partial y} = f'(x^2 - y^2) (-2y) \quad \dots(3)$$

$$\text{Dividing (2) by (3) we get } \frac{p}{q} = \frac{-x}{y} \quad \text{or} \quad py = -qx$$

$$\text{or} \quad yp + xq = 0 \quad \text{Ans.}$$

EXERCISE 9.1

Form the partial differential equation

1. $z = (x + a)(y + b)$

Ans. $pq = z$

2. $(x - h)^2 + (y - k)^2 + z^2 = a^2$

Ans. $z^2(p^2 + q^2 + 1) = a^2$

3. $2z = (ax + y)^2 + b$

Ans. $px + qy = z^2$

4. $ax^2 + by^2 + z^2 = 1$

Ans. $z(px + qy) = z^2 - 1$

5. $x^2 + y^2 = (z - c)^2 \tan^2 \alpha$

Ans. $yp - xq = 0$

6. $z = f(x^2 + y^2)$

Ans. $yp - xq = 0$

7. $2z = \frac{x^2}{a^2} + \frac{y^2}{b^2}$ (A.M.I.E., Winter 2001)

Ans. $2z = xp + yq$

8. $f(x + y + z, x^2 + y^2 + z^2) = 0$

Ans. $(y - z)p + (z - x)q = x - y$

SOLUTION OF EQUATION BY DIRECT INTEGRATION

Example 3. Solve $\frac{\partial^3 z}{\partial x^2 \partial y} = \cos(2x + 3y)$

Solution. $\frac{\partial^3 z}{\partial x^2 \partial y} = \cos(2x + 3y)$

Integrating w.r.t. 'x', we get $\frac{\partial^2 z}{\partial x \partial y} = \frac{1}{2} \sin(2x + 3y) + f(y)$

Integrating w.r.t. x, we get $\frac{\partial z}{\partial y} = -\frac{1}{4} \cos(2x + 3y) + x \int f(y) dy + g(y)$

Partial Differential Equations

$$= -\frac{1}{4} \cos(2x + 3y) + x\phi(y) + g(y)$$

Integrating w.r.t. 'y' we get

$$z = \frac{1}{12} \sin(2x + 3y) + x \int \phi(y) dy + \int g(y) dy$$

$$z = -\frac{1}{12} \sin(2x + 3y) + x\phi_1(y) + \phi_2(y)$$

Ans.

Example 4. Solve $\frac{\partial^2 z}{\partial x \partial y} = x^2 y$

subject to the condition $z(x, 0) = x^2$ and $z(1, y) = \cos y$.

Solution. $\frac{\partial}{\partial x} \left(\frac{\partial z}{\partial y} \right) = x^2 y$

On integrating w.r.t. x, we obtain $\frac{\partial z}{\partial y} = \frac{x^3}{3} y + f(y)$

Integrating w.r.t. y, we obtain $z = \frac{x^3}{3} \cdot \frac{y^2}{2} + \int f(y) dy + g(x)$

$$[F(y) = \int f(y) dy]$$

or $z = \frac{x^3 y^2}{6} + F(y) + g(x) \dots (1)$

Condition 1: Putting $z = x^2$ and $y = 0$ in (1), we get

$$x^2 = 0 + F(0) + g(x)$$

Putting the value of $g(x)$ in (1), we get $z = \frac{x^3 y^2}{6} + F(y) + x^2 - F(0) \dots (2)$

Condition 2: $z(1, y) = \cos y$

Putting $x = 1$ and $z = \cos y$ in (2), we get

$$\cos y = \frac{y^2}{6} + F(y) + 1 - F(0)$$

Putting the value of $F(y)$ in (2), we obtain

$$z = \frac{1}{6} x^3 y^2 + \cos y - \frac{1}{6} y^2 - 1 + F(0) + x^2 - F(0)$$

or

$$z = \frac{1}{6} x^3 y^2 + \cos y - \frac{1}{6} y^2 - 1 + x^2$$

Ans.

Example 5. Solve $\frac{\partial^2 z}{\partial y^2} = z$, if $y = 0$, $z = e^x$ and $\frac{\partial z}{\partial y} = e^{-x}$

Solution. If z is a function of y alone, then

$$z = \sinh y \cdot f(x) + \cosh y \cdot \phi(x) \dots (1)$$

$$\frac{\partial^2 z}{\partial y^2} = z \Rightarrow (D^2 - 1)z = 0 \Rightarrow m = \pm 1$$

$$\Rightarrow z = A e^y + B e^{-y} = A \sinh y + B \cosh y$$

$$= f(x) \sinh y + \phi(x) \cdot \cosh y$$

Partial Differential Equations

On putting $y = 0$ and $z = e^x$ in (1), we obtain

$$e^x = \phi(x)$$

(1) becomes $z = \sinh y \cdot f(x) + \cosh y \cdot e^x$... (2)

On differentiating (2) w.r.t. y , we get

$$\frac{\partial z}{\partial y} = \cosh y \cdot f(x) + \sinh y \cdot e^x$$
 ... (3)

On putting $y = 0$ and $\frac{\partial z}{\partial y} = e^{-x}$ in (3), we obtain

$$e^{-x} = f(x)$$

(2) becomes, $z = e^{-x} \sinh y + e^x \cosh y$ **Ans.**

EXERCISE 9.2

Solve the following:

- $\frac{\partial^2 z}{\partial x^2} = xy$ **Ans.** $z = \frac{x^2 y^3}{6} + f(y) + \phi(x)$
- $\frac{\partial x \partial y}{\partial^2 z} = e^y \cos x$ **Ans.** $z = e^y \sin x + f(y) + \phi(x)$
- $\frac{\partial x \partial y}{\partial^2 z} = \frac{y}{x} + 2$ **Ans.** $z = \frac{y^2}{2} \log x + 2xy + f(y) + \phi(x)$
- $\frac{\partial x^2}{\partial^2 z} = a^2 z$, when $x=0$, $\frac{\partial z}{\partial x} = a \sin y$ and $\frac{\partial z}{\partial y} = 0$ **Ans.** $z = \sin x + e^y \cos x$
- $\frac{\partial x \partial y}{\partial^2 z} = \sin x \sin y$ if $\frac{\partial z}{\partial y} = -2 \sin y$ when $x=0$, and $z=0$ when y is an odd multiple of $\frac{\pi}{2}$. **Ans.** $z = \cos x \cos y + \cos y$
- The partial differential equation $y \frac{\partial^2 u}{\partial x^2} + 2x \frac{\partial^2 u}{\partial x \partial y} + y \frac{\partial^2 u}{\partial y^2} = 0$ is elliptic if
 - $x^2 = y^2$
 - $x^2 < y^2$
 - $x^2 + y^2 > 1$
 - $x^2 + y^2 = 1$
 (A.M.I.E.T.E., Dec. 2004) **Ans.** (b)

LAGRANGE'S LINEAR EQUATION IS AN EQUATION OF THE TYPE

$$Pp + Qq = R$$

where P, Q, R are the functions of x, y, z and $p = \frac{\partial z}{\partial x}, q = \frac{\partial z}{\partial y}$

Solution. $Pp + Qq = R$... (1)

This form of the equation is obtained by eliminating an arbitrary function f from

$$f(u, v) = 0$$
 ... (2)

where u, v are functions of x, y, z .

Differentiating (2) partially w.r.t. to x and y .

$$\frac{\partial f}{\partial u} \left(\frac{\partial u}{\partial x} + \frac{\partial u}{\partial z} \frac{\partial z}{\partial x} \right) + \frac{\partial f}{\partial v} \left(\frac{\partial v}{\partial x} + \frac{\partial v}{\partial z} \frac{\partial z}{\partial x} \right) = 0$$
 ... (3) and $\frac{\partial f}{\partial u} \left(\frac{\partial u}{\partial y} + \frac{\partial u}{\partial z} \frac{\partial z}{\partial y} \right) + \frac{\partial f}{\partial v} \left(\frac{\partial v}{\partial y} + \frac{\partial v}{\partial z} \frac{\partial z}{\partial y} \right) = 0$... (4)

Let us eliminate $\frac{\partial f}{\partial u}$ and $\frac{\partial f}{\partial v}$ from (3) and (4).

Partial Differential Equations

$$\text{From (3), } \frac{\partial f}{\partial u} \left[\frac{\partial u}{\partial x} + \frac{\partial u}{\partial z} p \right] = - \frac{\partial f}{\partial v} \left[\frac{\partial v}{\partial x} + \frac{\partial v}{\partial z} p \right] \quad \dots(5)$$

$$\text{From (4), } \frac{\partial f}{\partial u} \left[\frac{\partial u}{\partial y} + \frac{\partial u}{\partial z} q \right] = - \frac{\partial f}{\partial v} \left[\frac{\partial v}{\partial y} + \frac{\partial v}{\partial z} q \right] \quad \dots(6)$$

$$\text{Dividing (5) by (6), we get } \frac{\frac{\partial u}{\partial x} + \frac{\partial u}{\partial z} \cdot p}{\frac{\partial u}{\partial y} + \frac{\partial u}{\partial z} \cdot q} = \frac{\frac{\partial v}{\partial x} + \frac{\partial v}{\partial z} \cdot p}{\frac{\partial v}{\partial y} + \frac{\partial v}{\partial z} \cdot q}$$

$$\text{or } \left[\frac{\partial u}{\partial x} + \frac{\partial u}{\partial z} \cdot p \right] \left[\frac{\partial v}{\partial y} + \frac{\partial v}{\partial z} \cdot q \right] = \left[\frac{\partial u}{\partial y} + \frac{\partial u}{\partial z} \cdot q \right] \left[\frac{\partial v}{\partial x} + \frac{\partial v}{\partial z} \cdot p \right]$$

$$\frac{\partial u}{\partial x} \times \frac{\partial v}{\partial y} + \frac{\partial u}{\partial x} \times \frac{\partial v}{\partial z} \cdot q + \frac{\partial u}{\partial z} \times p \times \frac{\partial v}{\partial y} + \frac{\partial u}{\partial z} \times \frac{\partial v}{\partial z} \cdot pq$$

$$\text{or } \begin{aligned} &= \frac{\partial u}{\partial y} \times \frac{\partial v}{\partial x} + \frac{\partial u}{\partial y} \times \frac{\partial v}{\partial z} \cdot p + \frac{\partial u}{\partial z} \cdot q \times \frac{\partial v}{\partial y} + \frac{\partial u}{\partial z} \times \frac{\partial v}{\partial z} \cdot pq \\ &\left[\frac{\partial u}{\partial y} \times \frac{\partial v}{\partial z} - \frac{\partial u}{\partial z} \times \frac{\partial v}{\partial y} \right] p + \left[\frac{\partial u}{\partial z} \times \frac{\partial v}{\partial x} - \frac{\partial u}{\partial x} \times \frac{\partial v}{\partial z} \right] q = \frac{\partial u}{\partial x} \times \frac{\partial v}{\partial y} - \frac{\partial u}{\partial y} \times \frac{\partial v}{\partial x} \end{aligned} \quad \dots(7)$$

If (1) and (7) are the same, then the coefficients of p, q are equal.

$$\begin{aligned} P &= \frac{\partial u}{\partial y} \times \frac{\partial v}{\partial z} - \frac{\partial u}{\partial z} \times \frac{\partial v}{\partial y} \\ Q &= \frac{\partial u}{\partial z} \times \frac{\partial v}{\partial x} - \frac{\partial u}{\partial x} \times \frac{\partial v}{\partial z} \\ R &= \frac{\partial u}{\partial x} \times \frac{\partial v}{\partial y} - \frac{\partial u}{\partial y} \times \frac{\partial v}{\partial x} \end{aligned} \quad \dots(8)$$

Now suppose $u = c_1$ and $v = c_2$ are two solutions, where a, b are constants.

Differentiating $u = c_1$ and $v = c_2$

$$\frac{\partial u}{\partial x} dx + \frac{\partial u}{\partial y} dy + \frac{\partial u}{\partial z} dz = 0 \quad \dots(9)$$

$$\text{and } \frac{\partial v}{\partial x} dx + \frac{\partial v}{\partial y} dy + \frac{\partial v}{\partial z} dz = 0 \quad \dots(10)$$

Solving (9) and (10), we get

$$\frac{dx}{\frac{\partial u}{\partial y} \times \frac{\partial v}{\partial z} - \frac{\partial u}{\partial z} \times \frac{\partial v}{\partial y}} = \frac{dy}{\frac{\partial u}{\partial z} \times \frac{\partial v}{\partial x} - \frac{\partial u}{\partial x} \times \frac{\partial v}{\partial z}} = \frac{dz}{\frac{\partial u}{\partial x} \times \frac{\partial v}{\partial y} - \frac{\partial u}{\partial y} \times \frac{\partial v}{\partial x}} \quad \dots(11)$$

$$\text{From (8) and (11) } \frac{dx}{P} = \frac{dy}{Q} = \frac{dz}{R}$$

Solutions of these equations are $u = c_1$ and $v = C_2$

$\therefore f(u, v) = 0$ is the required solution of (1).

WORKING RULE

First step. Write down the auxiliary equations

$$\frac{dx}{P} = \frac{dy}{Q} = \frac{dz}{R}$$

Partial Differential Equations

Second step. Solve the above auxiliary equations.

Let the two solutions be $u = c_1$ and $v = c_2$.

Third step. Then $f(u, v) = 0$ or $u = \phi(v)$ is the required solution of

$$Pp + Qq = R.$$

Example 6. Solve the following partial differential equation

$$yq - xp = z. \quad \text{where } p = \frac{\partial z}{\partial x}, q = \frac{\partial z}{\partial y}.$$

Solution.

$$yq - xp = z$$

Here the auxiliary equations are

$$\Rightarrow \frac{dx}{-x} = \frac{dy}{y} = \frac{dz}{z}$$

$$\Rightarrow -\log x = \log y - \log a \quad \text{(From first two equations)}$$

$$\Rightarrow xy = a \quad \dots(1)$$

$$\Rightarrow \log y = \log z + \log b \quad \text{(From last two equations)}$$

$$\frac{y}{z} = b \quad \dots(2)$$

From (1) and (2)

Hence the solution is $f\left(x, y, \frac{y}{z}\right) = 0$

Ans.

Example 7. Solve $y^2p - xyq = x(z - 2y)$

(A.M.I.E., Summer 2001)

Solution.

$$y^2p - xyq = x(z - 2y)$$

The auxiliary equations are

$$\frac{dx}{y^2} = \frac{dy}{-xy} = \frac{dz}{x(z - 2y)} \quad \dots(1)$$

Considering first two members of the equations

$$\frac{dx}{y} = \frac{dy}{-x} \Rightarrow x dx = -y dy$$

Integrating $\frac{x^2}{2} = -\frac{y^2}{2} + \frac{C}{2} \Rightarrow x^2 + y^2 = C_1 \quad \dots(2)$

From last two equations of (1)

$$-z dy = \frac{dz}{y} \frac{y^2}{z - 2y}$$

$$\Rightarrow -z dy + 2y dy = y dz \Rightarrow 2y dy = y dz + z dy$$

On integration, we get

$$y^2 = yz + C_2$$

$$y^2 - yz = C_2 \dots\dots\dots(3)$$

From (2) and (3)

$$x^2 + y^2 = f(y^2 - yz) \quad \text{Ans.}$$

Partial Differential Equations

Example 8. Solve $(x^2 - yz)p + (y^2 - zx)q = z^2 - xy$ (A.M.I.E., Summer 2001)

Solution. $(x^2 - yz)p + (y^2 - zx)q = z^2 - xy$... (1)

The auxiliary equations are

$$\frac{dx}{x^2 - yz} = \frac{dy}{y^2 - zx} = \frac{dz}{z^2 - xy}$$

or

$$\frac{dx - dy}{x^2 - yz - y^2 + zx} = \frac{dy - dz}{y^2 - zx - z^2 + xy} = \frac{dz - dx}{z^2 - xy - x^2 + yz}$$

$$\frac{dx - dy}{(x - y)(x + y + z)} = \frac{dy - dz}{(x + y + z)(y - z)} = \frac{dz - dx}{(x + y + z)(z - x)}$$

$$\frac{dx - dy}{(x - y)} = \frac{dy - dz}{(y - z)} = \frac{dz - dx}{(z - x)} \quad \dots (2)$$

Integrating first members of (2), we have

$$\log(x - y) = \log(y - z) + \log c_1$$

$$\frac{x - y}{y - z} = c_1$$

Similarly from last two members of (2), we have

$$\frac{y - z}{z - x} = c_2$$

The required solution is

$$f\left[\frac{x - y}{y - z}, \frac{y - z}{z - x}\right] = 0$$

Ans.

METHOD OF MULTIPLIERS

Let the auxiliary equations be

$$\frac{dx}{p} = \frac{dy}{Q} = \frac{dz}{R}$$

l, m, n may be constants or functions of x, y, z then we have

$$\frac{dx}{p} = \frac{dy}{Q} = \frac{dz}{R} = \frac{ldx + mdy + ndz}{lp + mQ + nR}$$

l, m, n are chosen in such a way that

$$lP + mQ + nR = 0$$

Thus

$$ldx + mdy + ndz = 0$$

Solve this differential equation, if the solution is $u = c_1$.

Similarly, choose another set of multipliers (l_1, m_1, n_1) and if the second solution is $v = C_2$.

\therefore Required solution is $f(u, v) = 0$.

Example 9. Solve

$$(mz - ny) \frac{\partial z}{\partial x} + (nx - lz) \frac{\partial z}{\partial y} = ly - mx \quad \text{(A.M.I.E. Winter 2001)}$$

Solution. $(mz - ny) \frac{\partial z}{\partial x} + (nx - lz) \frac{\partial z}{\partial y} = ly - mx$

Partial Differential Equations

Here, the auxiliary equations are

$$\frac{dx}{mz - ny} = \frac{dy}{nx - lz} = \frac{dz}{ly - mx}$$

Using multipliers x, y, z we get

$$\text{Each fraction} = \frac{x dx + y dy + z dz}{x(mz - ny) + y(nx - lz) + z(ly - mx)} = \frac{x dx + y dy + z dz}{0}$$

$$\therefore \Rightarrow x dx + y dy + z dz = 0$$

$$\text{which on integration gives } x^2 + y^2 + z^2 = c_1 \dots \dots \dots (1)$$

Again using multipliers, l, m, n , we get

$$\text{each fraction} = \frac{l dx + m dy + n dz}{l(mz - ny) + m(nx - lz) + n(ly - mx)} = \frac{l dx + m dy + n dz}{0}$$

$$\therefore \Rightarrow l dx + m dy + n dz = 0$$

which, on integration gives.

$$lx + my + nz = c_2 \dots \dots \dots (2)$$

Hence from (1) and (2), the required solution is $x^2 + y^2 + z^2 = f(lx + my + nz)$ **Ans.**

Example 10. Find the general solution of

$$x(z^2 - y^2) \frac{\partial z}{\partial x} + y(x^2 - z^2) \frac{\partial z}{\partial y} = z(y^2 - x^2)$$

$$\text{Solution. } x(z^2 - y^2) \frac{\partial z}{\partial x} + y(x^2 - z^2) \frac{\partial z}{\partial y} = z(y^2 - x^2)$$

The auxiliary simultaneous equations are

$$\frac{dx}{x(z^2 - y^2)} = \frac{dy}{y(x^2 - z^2)} = \frac{dz}{z(y^2 - x^2)} \dots (1)$$

Using multipliers x, y, z we get

Each term of (1) is equal to

$$\frac{xdx + y dy + z dz}{x^2(z^2 - y^2) + y^2(x^2 - z^2) + z^2(y^2 - x^2)} = \frac{xdx + y dy + z dz}{0}$$

$$\Rightarrow x dx + y dy + z dz = 0$$

$$\text{On integration } x^2 + y^2 + z^2 = C_1 \dots (2)$$

Again (1) can be written as

$$\frac{\frac{dx}{x}}{z^2 - y^2} = \frac{\frac{dy}{y}}{x^2 - z^2} = \frac{\frac{dz}{z}}{y^2 - x^2} = \frac{\frac{dx}{x} + \frac{dy}{y} + \frac{dz}{z}}{(z^2 - y^2) + (x^2 - z^2) + (y^2 - x^2)} = \frac{\frac{dx}{x} + \frac{dy}{y} + \frac{dz}{z}}{0}$$

$$\Rightarrow \frac{dx}{x} + \frac{dy}{y} + \frac{dz}{z} = 0$$

$$\Rightarrow \log x + \log y + \log z = \log C_2$$

$$\Rightarrow \log xyz = \log C_2 \quad \Rightarrow \quad xyz = C_2 \dots (3)$$

From (2) and (3), the general solution is $xyz = f(x^2 + y^2 + z^2)$ **Ans.**

Partial Differential Equations

Example 11. Solve the partial differential equation

$$\frac{y-z}{yz} p = \frac{z-x}{zx} q = \frac{x-y}{xy} \quad (\text{A.M.I.E., Winter 2001})$$

Solution. $\frac{y-z}{yz} p = \frac{z-x}{zx} q = \frac{x-y}{xy}$

Multiplying by xyz , we get

$$x(y-z)p + y(z-x)q = z(x-y)$$

$$\frac{dx}{x(y-z)} = \frac{dy}{y(z-x)} = \frac{dz}{z(x-y)} = \frac{dz+dy+dx}{x(y-z)+y(z-x)+z(x-y)} \quad \dots (1)$$

$$= \frac{dx+dy+dz}{0}$$

$$\therefore dx+dy+dz=0$$

Which on integration gives

$$x+y+z=a \quad \dots (2)$$

Again (1) can be written

$$\frac{\frac{dx}{x}}{y-z} = \frac{\frac{dy}{y}}{z-x} = \frac{\frac{dz}{z}}{x-y} = \frac{\frac{dx}{x} + \frac{dy}{y} + \frac{dz}{z}}{(y-z)+(z-x)+(x-y)} = \frac{\frac{dx}{x} + \frac{dy}{y} + \frac{dz}{z}}{0}$$

or $\frac{dx}{x} + \frac{dy}{y} + \frac{dz}{z} = 0$

On integration we get

$$\log x + \log y + \log z = \log b \Rightarrow \log xyz = \log b \Rightarrow xyz = b \quad \dots (3)$$

From (2) and (3) the general solution is

$$xyz = f(x+y+z) \quad \text{Ans.}$$

Example 12. Solve $(x^2 - y^2 - z^2)p + 2xyq = 2xz$. (A.M.I.E., Summer, 2004, 2000)

Solution. $(x^2 - y^2 - z^2)p + 2xyq = 2xz$

Here the auxiliary equations are

$$\frac{dx}{x^2 - y^2 - z^2} = \frac{dy}{2xy} = \frac{dz}{2xz} \quad \dots (1)$$

From the last two members of (1) we have dz

$$\frac{dy}{y} = \frac{dz}{z}$$

which on integration gives

$$\log y = \log z + \log a \quad \text{or} \quad \log \frac{y}{z} = \log a$$

or $\frac{y}{z} = a \quad \dots (2)$

Using multipliers x, y, z we have

$$\frac{dx}{x^2 - y^2 - z^2} = \frac{dy}{2xy} = \frac{dz}{2xz} = \frac{xdx + ydy + zdz}{x(x^2 + y^2 + z^2)}$$

Partial Differential Equations

$$\frac{2x dx + 2y dy + 2z dz}{(x^2 + y^2 + z^2)} = \frac{dz}{z}$$

which on integration gives

$$\log(x^2 + y^2 + z^2) = \log z + \log b$$

$$\frac{x^2 + y^2 + z^2}{b} = \dots(3)$$

Hence from (2) and (3), the required solution is

$$x^2 + y^2 + z^2 = z f\left(\frac{y}{z}\right) \quad \text{Ans.}$$

Example 13. Solve the differential equation

$$x^2 \frac{\partial z}{\partial x} + y^2 \frac{\partial z}{\partial y} = (x + y)z.$$

Solution. $x^2 \frac{\partial z}{\partial x} + y^2 \frac{\partial z}{\partial y} = (x + y)z. \dots(1)$

The auxiliary equations of (1) are

$$\frac{dx}{x^2} = \frac{dy}{y^2} = \frac{dz}{(x + y)z} \dots(2)$$

Take first two members of (2) and integrate them

$$\frac{1}{x} = -\frac{1}{y} + c$$

$$\frac{1}{x} - \frac{1}{y} = c \dots(3)$$

(2) can be written as $\frac{dx}{x} = \frac{dy}{y} + \frac{dz}{z} = \frac{dx}{x} + \frac{dy}{y} - \frac{dz}{z}$

or $\frac{dx}{x} + \frac{dy}{y} - \frac{dz}{z} = 0$

On integration we get

or $\log x + \log y - \log z = \log c_2$

or $\log \frac{xy}{z} = \log c_2$ or $\frac{xy}{z} = c_2 \dots(4)$

From (3) and (4) we have

$$f\left[\frac{1}{x} - \frac{1}{y}, \frac{xy}{z}\right] = 0 \quad \text{Ans.}$$

Example 14. Find the general solution of

$$x \frac{\partial z}{\partial x} + y \frac{\partial z}{\partial y} + t \frac{\partial z}{\partial t} = xyt$$

Solution. The auxiliary equations are $\frac{dx}{x} = \frac{dy}{y} = \frac{dt}{t} = \frac{dz}{xyt} \dots(1)$

Taking the first two members and integrating, we get

$$\log x = \log y + \log a$$

Partial Differential Equations

$\Rightarrow \log x = \log ay \Rightarrow x = ay \Rightarrow y/x = a$... (2)
 Similarly, from the 2nd and 3rd members

$$\frac{t}{y} = b \quad \dots (3)$$

Multiplying the equations (1) by xyt , we get

$$dz = \frac{tydx}{1} = \frac{txdy}{1} = \frac{xydt}{1} = \frac{tydx + txdy + xydt}{3}$$

Integrating,

$$z = \frac{1}{3}xyt + c \quad \text{or} \quad z - \frac{1}{3}xyt = c \quad \dots (4)$$

From (2), (3) and (4) the solution is $z - \frac{1}{3}xyt = f\left(\frac{y}{x}\right) + \phi\left(\frac{t}{y}\right)$ **Ans.**

Example 15. Solve $(y + z)p - (x + z)q = x - y$

Solution. $(y+z)p - (x+z)q = x - y$... (1)

\therefore The auxiliary equations are

$$\frac{dx}{y+z} = \frac{dy}{-(x+z)} = \frac{dz}{x-y} \quad \dots (2)$$

$\Rightarrow \frac{dx}{y+z} = \frac{dy}{-(x+z)} = \frac{dz}{x-y} = \frac{dx+dy+dz}{y+z-(x+z)+x-y}$

$\Rightarrow \frac{dz}{x-y} = \frac{dx+dy+dz}{0}$

Thus, we have $dx + dy + dz = 0$
 which on integration gives $x + y + z = c_1$, ... (3)

Let us use multipliers $(x, y, -z)$ for (2)

$$\frac{dx}{y+z} = \frac{dy}{-(x+z)} = \frac{dz}{x-y} = \frac{x dx + y dy + z dz}{x(y+z) - y(x+z) - z(x-y)}$$

or $\frac{dx}{y+z} = \frac{dy}{-(x+z)} = \frac{dz}{x-y} = \frac{x dx + y dy - z dz}{0}$

Integrating $x dx + y dy - z dz = 0$, we get

$$\frac{x^2}{2} + \frac{y^2}{2} - \frac{z^2}{2} = c_2$$

or $x^2 + y^2 - z^2 = 2c_2$... (4)

From (3) and (4), we get the required solution

$f(x + y + z, x^2 + y^2 - z^2) = 0$ **Ans.**

Example 16. Solve $zp + yq = x$

Solution. $zp + yq = x$... (1)

The auxiliary equations are $\frac{dx}{z} = \frac{dy}{y} = \frac{dz}{x}$

- (i)
- (ii)
- (iii)

Partial Differential Equations

From (i) and (ii) $\frac{dx}{z} = \frac{dz}{x}$ or $x \cdot dx = z \cdot dz$

$$\Rightarrow \frac{x^2}{2} = \frac{z^2}{2} - \frac{c_1}{2} \text{ or } x^2 = z^2 - c_1 \quad \dots(2)$$

$$\Rightarrow z = \sqrt{x^2 + c_1}$$

Putting the value of z in (1)

$$\frac{dx}{\sqrt{x^2 + c_1}} = \frac{dy}{y}$$

$$\sinh^{-1} \frac{x}{\sqrt{c_1}} = \log y + c_2 \text{ or } \sinh^{-1} \frac{x}{\sqrt{c_1}} - \log y = c_2 \quad \dots(3)$$

From (2) and (3), the required solution is

$$f(z^2 - x^2) = \sinh^{-1} \frac{x}{\sqrt{c_1}} - \log y \quad \text{Ans.}$$

Example 17. Solve $px(z - 2y^2) = (z - qy)(z - y^2 - 2x^3)$. (A.M.I.E., Summer 2000)

Solution. $px(z - 2y^2) = (z - qy)(z - y^2 - 2x^3) \quad \dots(1)$

$$\Rightarrow px(z - 2y^2) + qy(z - y^2 - 2x^3) = z(z - y^2 - 2x^3)$$

Here the auxiliary equations are

$$\frac{dx}{x(z - 2y^2)} = \frac{dy}{y(z - y^2 - 2x^3)} = \frac{dz}{z(z - y^2 - 2x^3)} \quad \dots(2)$$

From the last two members of (2) we have

$$\frac{dy}{y} = \frac{dz}{z}$$

which gives on integration

$$\log y = \log z + \log a \text{ or } y = az \quad \dots(3)$$

From the first and third members of (2) we have

$$\frac{dx}{x(z - 2y^2)} = \frac{dz}{z(z - y^2 - 2x^3)}$$

Put $y = az$

$$\Rightarrow \frac{dx}{x(z - 2a^2z^2)} = \frac{dz}{z(z - a^2z^2 - 2x^3)}$$

$$\frac{dx}{x(1 - 2a^2z)} = \frac{dz}{z - a^2z^2 - 2x^3}$$

$$\Rightarrow z \, dx - a^2z^2 \, dx - 2x^3 \, dx = x \, dz - 2a^2xz \, dz$$

$$\Rightarrow (x \, dz - z \, dx) - a^2(2xz \, dz - z^2 \, dx) + 2x^3 \, dx = 0$$

On integrating, we have

$$\frac{z}{x} - a^2 \frac{z^2}{x} + x^2 = b \quad \dots(4)$$

From (3) and (4), we have

$$y \left(\frac{z}{x} - a^2 \frac{z^2}{x} \right) = f \left(\frac{z}{x} - a^2 \frac{z^2}{x} + x^2 \right) \quad \text{Ans.}$$

$$z \left(\frac{x}{x} - a^2 \frac{x^2}{x} \right)$$

Partial Differential Equations

EXERCISE 9.3

Solve the following partial differential equations :

1. $p \tan x + q \tan y = \tan z$ Ans. $f\left(\frac{\sin x}{\sin y}, \frac{\sin y}{\sin z}\right) = 0$
2. $y \frac{\partial z}{\partial x} + y \frac{\partial z}{\partial y} = z + 1$ (AMIE. Winter 2002) Ans. $f(x - y) = \log y - \tan^{-1} z$
3. $(y \frac{\partial x}{\partial z})p + (x - y)q = z - x$ Ans. $f(x + y + z, x^2 + 2yz) = 0$
4. $(y + zx)p - (x + yz)q = x^2 - y^2$ Ans. $f(x^2 + y^2 - z^2) = (x - y)^2 - (z + 1)^2$
5. $zx \frac{\partial}{\partial x} - zy \frac{\partial}{\partial y} = y - x$ Ans. $f(x^2 + y^2 + z^2, xy) = 0$
6. $pz \frac{\partial x}{\partial z} = z^2 + (x + y)^2$ Ans. $[z^2 + (x + y)^2] e^{-2x} = f(x + y)$
7. $p + q + 2xz = 0$ Ans. $f(x - y) = x^2 + \log z$
8. $x^2p + y^2q + z^2 = 0$ Ans. $f\left(\frac{1}{y}, \frac{1}{x}, \frac{1}{y}, \frac{1}{z}\right) = 0$
9. $(x^2 + y^2)p + 2xyq = (x + y)z$ Ans. $f\left(\frac{x + y}{z}, \frac{x^2 + y^2}{z^2}\right) = 0$
10. $\frac{\partial z}{\partial x} - 2 \frac{\partial z}{\partial y} = 2x - e^y + 1$ Ans. $f(2x + y) = z - \frac{(2x + 1)^2 e^y}{4} - \frac{e^{5x}}{2}$
11. $p + 3q = 5z + \tan(y - 3x)$ Ans. $f(y - 3x) = \frac{5z + \tan(y - 3x)}{5z + \tan(y - 3x)}$
12. $xp - yq + x^2 - y^2 = 0$ Ans. $f(xy) = \frac{x^2}{2} + \frac{y^2}{2} + z$
13. $(x + y) \left(\frac{\partial z}{\partial x} + \frac{\partial z}{\partial y} \right) = z - 1$ Ans. $f(x - y) = \frac{x^2 + y^2}{(z - 1)^2}$
14. $(x^3 + 3xy^2) \frac{\partial z}{\partial x} + (y^3 + 3x^2y) \frac{\partial z}{\partial y} = 2(x^2 + y^2)z$ Ans. $f\left(\frac{xy}{z^2}, (x - y)^{-2}, -(x + y)^{-2}\right) = 0$
15. $(z^2 - 2yz - y^2)P + (xy + zx)q = xy - zx$ Ans. $(x^2 + y^2 + z^2) = f(y^2 - 2yz - z^2)$
16. Find the solution of the equation $\frac{x \partial z}{\partial y} - \frac{y \partial z}{\partial x} = 0$, which passes through the curve $z = 1$, Ans. $f(x^2 + y^2 - 4, z - 1) = 0$
17. $2x(y + z^2)p + y(2y + z^2)q = z^3$ (AMIE Winter 2003)
18. $3 \frac{\partial u}{\partial x} + 2 \frac{\partial u}{\partial y} = 0, u(x, 0) = 4e^{-x}$ Ans. $u = ue^{-x + \frac{3y}{2}}$
19. $4 \frac{\partial u}{\partial t} + \frac{\partial u}{\partial x} = 3u, \text{ when } t = 0, u = 3e^{-x} - e^{-5x}$ Ans. $u = 3e^{-x+t} - 3e^{-5x+2t}$

PARTIAL DIFFERENTIAL EQUATIONS NON-LINEAR IN p AND q.

We give below the methods of solving non-linear partial differential equations in certain standard form only.

Type I. Equation of the Type $f(p, q) = 0$ i.e., equations containing p and q only.

Method. Let the required solution be

$$z = ax + by + c \quad \dots(1)$$

$$\therefore \frac{\partial z}{\partial x} = a, \quad \frac{\partial z}{\partial y} = b.$$

Partial Differential Equations

On putting these values in $f(p, q) = 0$
we get $f(a, b) = 0$,

From this, find the value of b in terms of a and substitute the value of b in (1), that will be the required solution.

Example 18. Solve $p^2 + q^2 = 1$... (1)

Solution. Let $z = ax + by + c$... (2)

$$\therefore p = \frac{\partial z}{\partial x} = a, \quad q = \frac{\partial z}{\partial y} = b$$

On substituting the values of p and q in (1), we have

$$\therefore a^2 + b^2 = 1 \text{ or } b = \sqrt{1 - a^2}$$

Putting the value of b in (2), we get $z = ax + \sqrt{1 - a^2} y + c$

This is the required solution.

Ans.

Example 19. Solve $x^2 p^2 + y^2 q^2 = z^2$.

(RGPV, Bhopal, Feb. 2008)

Solution. This equation can be transformed in the above type.

$$\begin{aligned} \frac{x^2}{z^2} p^2 + \frac{y^2}{z^2} q^2 &= 1 \\ \Rightarrow \left(\frac{x}{z} \frac{\partial z}{\partial x} \right)^2 + \left(\frac{y}{z} \frac{\partial z}{\partial y} \right)^2 &= 1 \Rightarrow \left(\frac{\frac{\partial z}{z}}{\frac{x}{z}} \right)^2 + \left(\frac{\frac{\partial z}{z}}{\frac{y}{z}} \right)^2 = 1 \end{aligned} \quad \dots(1)$$

$$\text{Let } \frac{\partial z}{z} = \partial Z, \quad \frac{\partial x}{x} = \partial X, \quad \frac{\partial y}{y} = \partial Y,$$

$$\therefore \log z = Z, \quad \log x = X, \quad \log y = Y$$

\therefore (1) can be written as

$$\left(\frac{\partial Z}{\partial X} \right)^2 + \left(\frac{\partial Z}{\partial Y} \right)^2 = 1 \quad \dots(2)$$

$$\Rightarrow P^2 + Q^2 = 1$$

Let the required solution be

$$Z = aX + bY + c$$

$$P = \frac{\partial Z}{\partial X} = a, \quad Q = \frac{\partial Z}{\partial Y} = b$$

From (2) we have

$$a^2 + b^2 = 1 \text{ or } b = \sqrt{1 - a^2}$$

$$Z = aX + \sqrt{1 - a^2} Y + c$$

$$\log z = a \log x + \sqrt{1 - a^2} \log y + c$$

Ans.

EXERCISE 9.4

Solve the following partial differential equations

1. $pq = 1$ **Ans.** $z = ax + \frac{1}{a} y + c$ 2. $\sqrt{p} + \sqrt{q} = 1$ **Ans.** $z = ax + (1 - \sqrt{a})^2 y + c$

3. $p^2 - q^2 = 1$ **Ans.** $z = ax - \sqrt{(a^2 - 1)} y + c$ 4. $pq + p + q = 0$ **Ans.** $z = ax - \frac{a}{1+a} y + c$

Partial Differential Equations

Type II. Equation of the type

$$z = px + qy + f(p, q)$$

Its solution is $z = ax + by + f(a, b)$

Example 20. Solve $z = px + qy + p^2 + q^2$ **Solution.** $z = px + qy + p^2 + q^2$ $p = a, q = b$

Its solution is $z = ax + by + a^2 + b^2$

Ans.**Example 21. Solve** $z = px + qy + 2\sqrt{pq}$ **Solution.** $z = px + qy + 2\sqrt{pq}$

Its solution is $z = ax + by + 2\sqrt{ab}$

Ans.**Type III. Equation of the type $f(z, p, q) = 0$ equations not containing x and y .**Let z be a function of u where

$$u = x + ay.$$

$$\frac{\partial u}{\partial x} = 1 \quad \text{and} \quad \frac{\partial u}{\partial y} = a$$

Then

$$p = \frac{\partial z}{\partial x} = \frac{dz}{du} \cdot \frac{\partial u}{\partial x} = \frac{dz}{du}$$

$$q = \frac{\partial z}{\partial y} = \frac{dz}{du} \cdot \frac{\partial u}{\partial y} = \frac{dz}{du}(a)$$

On putting the values of p and q in the given equation $f(z, p, q) = 0$, it becomes

$$f\left(z, \frac{dz}{du}, a\frac{dz}{du}\right) = 0 \text{ which is an ordinary differential equation of the first order.}$$

Rule. Assume $u = x + ay$; replace p and q by $\frac{dz}{du}$ and $a\frac{dz}{du}$ in the given equation and then

solve the ordinary differential equation obtained.

Example 22. Solve

$$p(1 + q) = qz$$

Solution. $p(1 + q) = qz$... (1)

Let $u = x + ay \Rightarrow \frac{\partial u}{\partial x} = 1, \frac{\partial u}{\partial y} = a$

$$p = \frac{\partial z}{\partial x} = \frac{dz}{du} \cdot \frac{\partial u}{\partial x} = \frac{dz}{du} \quad \text{and} \quad q = \frac{\partial z}{\partial y} = \frac{dz}{du} \cdot \frac{\partial u}{\partial y} = a \frac{dz}{du}$$

(1) becomes

$$\frac{dz}{du} \left(1 + a \frac{dz}{du}\right) = a \frac{dz}{du} z \quad \text{or} \quad 1 + a \frac{\partial z}{\partial u} = az$$

$$\Rightarrow a \frac{dz}{du} = az - 1 \Rightarrow du = \frac{a dz}{az - 1}$$

Integrating, we get

$$u = \log(az - 1) + \log c$$

$$x + ay = \log c (az - 1)$$

Ans.

Partial Differential Equations

Example 23. Solve $p(1 + q^2) = q(z - a)$.

Solution. Let $u = x + by$

So that $p = \frac{dz}{du}$ and $q = b \frac{dz}{du}$

Substituting these values of p and q in the given equation, we have

$$\frac{dz}{du} \left[1 + b^2 \left(\frac{dz}{du} \right)^2 \right] = b \frac{dz}{du} (z - a)$$

$$1 + b^2 \left(\frac{dz}{du} \right)^2 = b(z - a) \quad \text{or} \quad b^2 \left(\frac{dz}{du} \right)^2 = bz - ab - 1$$

$$\frac{dz}{du} = \frac{1}{b} \sqrt{bz - ab - 1}$$

$$\int \frac{b dz}{\sqrt{bz - ab - 1}} = \int du + c$$

$$2\sqrt{bz - ab - 1} = u + c$$

$$4(bz - ab - 1) = (u + c)^2$$

$$4(bz - ab - 1) = (x + by + c)^2$$

Ans.

...(1)

Example 24. Solve $z^2(p^2x^2 + q^2) = 1$

Solution. $z^2(p^2x^2 + q^2) = 1$

$$\Rightarrow z^2 \left[\left(\frac{\partial z}{\partial x} \right)^2 + \left(\frac{\partial z}{\partial y} \right)^2 \right] = 1 \quad \Rightarrow \quad z^2 \left[\left(\frac{\partial z}{\partial x} \right)^2 + \left(\frac{\partial z}{\partial y} \right)^2 \right] = 1$$

$$\Rightarrow z^2 \left[\left(\frac{\partial z}{\partial X} \right)^2 + \left(\frac{\partial z}{\partial y} \right)^2 \right] = 1 \quad \dots(2)$$

where $\frac{\partial x}{x} = \partial X$ or $\log x = X$

Let

$$u = X + ay$$

$$\frac{\partial z}{\partial X} = \frac{dz}{du} \quad \text{and} \quad \frac{\partial z}{\partial y} = a \frac{dz}{du}$$

Then (2) becomes

$$z^2 \left[\left(\frac{dz}{du} \right)^2 + \left(a \frac{dz}{du} \right)^2 \right] = 1 \quad \Rightarrow \quad \left(\frac{dz}{du} \right)^2 + a^2 \left(\frac{dz}{du} \right)^2 = \frac{1}{z^2}$$

$$\Rightarrow \left(\frac{dz}{du} \right)^2 = \frac{1}{z^2(1+a^2)} \quad \Rightarrow \quad \frac{dz}{du} = \frac{1}{z\sqrt{1+a^2}} \quad \Rightarrow \quad z dz = \frac{du}{\sqrt{1+a^2}}$$

$$\Rightarrow \int z dz = \int \frac{du}{\sqrt{1+a^2}} + c \quad \text{or} \quad \frac{z^2}{2} = \frac{u}{\sqrt{1+a^2}} + c$$

$$\sqrt{1+a^2} \frac{z^2}{2} = u + c \sqrt{1+a^2}$$

$$= X + ay + c\sqrt{1+a^2}$$

$$= \log x + ay + c\sqrt{1+a^2}$$

Ans.

Partial Differential Equations

EXERCISE 9.5

Solve

$$1. \quad z^2 (p^2 + q^2 + 1) = 1 \quad \text{Ans.} \quad (1 - z^2)^z = -\frac{x+ay}{\sqrt{1+a^2}} + c$$

$$2. \quad 1 + q^2 = q(z-a) \quad \text{Ans.} \quad \frac{x+by}{b} + 4(z-a) = 4(z-a) \sqrt{(z-a)^2 - 2^2} + 4 \cosh^{-1} \left(\frac{z-a}{2} \right)$$

$$3. \quad x^2 p^2 + y^2 q^2 = z \quad \text{Ans.} \quad 2\sqrt{z} = \frac{\log x + a \log y}{\sqrt{1+a^2}} + c$$

Type IV. Equation of the type $f_1(x, p) = f_2(y, q)$

In these equations, z is absent and the terms containing x and p can be written on one side and the terms containing y and q can be written on the other side.

Method. Let $f_1(x, p) = f_2(y, q) = a$

$$f_1(x, p) = a, \text{ solve it for } p. \quad \text{Let } p = F_1(x)$$

$$f_2(y, q) = a, \text{ solve it for } q. \quad \text{Let } q = F_2(y)$$

$$\text{Since} \quad dz = \frac{\partial z}{\partial x} dx + \frac{\partial z}{\partial y} dy \Rightarrow dz = p dx + q dy$$

$$\Rightarrow dz = F_1(x) dx + F_2(y) dy \Rightarrow z = \int F_1(x) dx + \int F_2(y) dy + c$$

Example 25. Solve $p - x^2 = q + y^2$.

$$\text{Solution.} \quad p - x^2 = q + y^2 = c \quad (\text{say})$$

$$\text{i.e.} \quad p = x^2 + c \quad \text{and} \quad q = c - y^2$$

Putting these values of p and q in

$$dz = p dx + q dy = (x^2 + c) dx + (c - y^2) dy$$

$$z = \left(\frac{x^3}{3} + cx \right) + \left(cy - \frac{y^3}{3} \right) + c_1$$

Ans.

Example 26. Solve $p^2 + q^2 = z^2(x+y)$.

$$\text{Solution.} \quad p^2 + q^2 = z^2(x+y) \Rightarrow \left(\frac{p}{z} \right)^2 + \left(\frac{q}{z} \right)^2 = (x+y)$$

$$\Rightarrow \left(\frac{1}{z} \frac{\partial z}{\partial x} \right)^2 + \left(\frac{1}{z} \frac{\partial z}{\partial y} \right)^2 = x+y \Rightarrow \left(\frac{\partial z}{z \partial x} \right)^2 + \left(\frac{\partial z}{z \partial y} \right)^2 = x+y$$

$$\Rightarrow \left(\frac{\partial z}{\partial x} \right)^2 + \left(\frac{\partial z}{\partial y} \right)^2 = x+y \quad \text{where} \quad \frac{\partial z}{z} = \partial Z \quad \text{or} \quad \log z = Z$$

$$\Rightarrow p^2 + Q^2 = x+y \Rightarrow p^2 - x = y - Q^2 = a$$

$$P^2 - x = a \Rightarrow P = \sqrt{a+x}$$

$$y - Q^2 = a \Rightarrow Q = \sqrt{y-a}$$

$$\text{Therefore, the equation} \quad dZ = \frac{\partial Z}{\partial x} dx + \frac{\partial Z}{\partial y} dy$$

$$dZ = P dx + Q dy \text{ gives}$$

$$dZ = \sqrt{a+x} dx + \sqrt{y-a} dy$$

Partial Differential Equations

$$z = \int \sqrt{a+x} dx + \int \sqrt{y-a} dy + c$$

$$\Rightarrow \log z = \frac{2}{3}(a+x)^{3/2} + \frac{2}{3}(y-a)^{3/2} + c \quad \text{Ans.}$$

EXERCISE 9.6

Solve

1. $q - p + x - y = 0$

Ans. $2z = (x+a)^2 + (y+a)^2 + b$

2. $\sqrt{p} + \sqrt{q} = 2x$

Ans. $z = \frac{1}{6} (2x-q)^3 + a^2y + b$

3. $q = xp + p^2$

Ans. $z = -\frac{1}{4} + \left\{ \frac{\sqrt{x^2+4a}}{4} + a \log \left(x + \sqrt{x^2+4a} \right) \right\} + ay + b$

4. $z^2(p^2 + q^2) = x^2 + y^2$

Ans. $z^2 = x\sqrt{x^2+a} + a \log(x + \sqrt{x^2+a}) + y\sqrt{y^2-a} - a \log(y + \sqrt{y^2-a}) + 2b$

5. $z(p^2 + q^2) = x - y$

Ans. $z^{3/2} = \frac{1}{2}(x+a)^{3/2} + \frac{1}{2}(y+a)^{3/2} + b$

6. $p^2 - q^2 = x - y$

Ans. $z = \frac{1}{3}(x+c)^{3/2} + \frac{1}{3}(y+c)^{3/2} + c$

7. $(p^2 + q^2)y = qz$

Ans. $z^2 = (cx+a)^2 + c^2y^2$

8. Tick \checkmark the correct answer.(a) The partial differential equation from $z = (a+x)^2 + y$ is

(i) $z = \frac{1}{4} \left(\frac{\partial z}{\partial x} \right)^2 + y$ (ii) $z = \frac{1}{4} \left(\frac{\partial z}{\partial y} \right)^2 + y$ (iii) $z = \left(\frac{\partial z}{\partial x} \right)^2 + y$ (iv) $z = \left(\frac{\partial z}{\partial y} \right)^2 + y$

(b) The solution of $xp + yq = z$ is

(i) $f(x, y) = 0$ (ii) $f\left(\frac{x}{y}, \frac{y}{z}\right) = 0$ (iii) $f(xy, yz) = 0$ (iv) $f(x^2, y^2) = 0$

(c) The solution of $p + q = z$ is

(i) $f(x+y, y + \log z) = 0$ (ii) $f(xy, y \log z) = 0$
(iii) $f(x-y, y - \log z) = 0$ (iv) None of these

(d) The solution of $(y-z)p + (z-x)q = x-y$ is

(i) $f(x+y+z) = xyz$ (ii) $f(x^2 + y^2 + z^2) = xyz$
(iii) $f(x^2 + y^2 + z^2, x^2y^2z^2) = 0$ (iv) $f(x+y+z) = x^2 + y^2 + z^2$

Ans. (a) (i), (b) (ii), (c) (iii), (d), (iv)

CHARPIT'S METHOD

General method for solving partial differential equation with two independent variables.

Solution. Let the general partial differential equation be

$$f(x, y, z, p, q) = 0 \quad \dots (1)$$

Since z depends on x, y , we have

$$dz = \frac{\partial z}{\partial x} dx + \frac{\partial z}{\partial y} dy$$
$$dz = p dx + q dy \quad \dots (2)$$

The main aim in Charpits method is to find another relation between the variables x, y, z and p, q . Let the relation be

$$\phi(x, y, z, p, q) = 0 \quad \dots (3)$$

On solving (1) and (3), we get the values of p and q .

Partial Differential Equations

These values of p and q when substituted in (2), it becomes integrable.

To determine ϕ , (1) and (3) are differentiated w.r.t. x and y giving

$$\left. \begin{aligned} \frac{\partial f}{\partial x} + \frac{\partial f}{\partial z} p + \frac{\partial f}{\partial p} \frac{\partial p}{\partial x} + \frac{\partial f}{\partial q} \frac{\partial q}{\partial x} &= 0 \\ \frac{\partial \phi}{\partial x} + \frac{\partial \phi}{\partial z} p + \frac{\partial \phi}{\partial p} \frac{\partial p}{\partial x} + \frac{\partial \phi}{\partial q} \frac{\partial q}{\partial x} &= 0 \end{aligned} \right\} \text{w.r.t. } x, \text{ (First pair)}$$

$$\left. \begin{aligned} \frac{\partial f}{\partial y} + \frac{\partial f}{\partial z} q + \frac{\partial f}{\partial p} \frac{\partial p}{\partial y} + \frac{\partial f}{\partial q} \frac{\partial q}{\partial y} &= 0 \\ \frac{\partial \phi}{\partial y} + \frac{\partial \phi}{\partial z} q + \frac{\partial \phi}{\partial p} \frac{\partial p}{\partial y} + \frac{\partial \phi}{\partial q} \frac{\partial q}{\partial y} &= 0 \end{aligned} \right\} \text{w.r.t. } y, \text{ (Second pair)}$$

Eliminating $\frac{\partial p}{\partial x}$ between the equation of first pair, we have

$$\frac{\frac{\partial f}{\partial x} + \frac{\partial f}{\partial z} p + \frac{\partial f}{\partial q} \frac{\partial q}{\partial x}}{\frac{\partial f}{\partial p}} = \frac{\frac{\partial \phi}{\partial x} + \frac{\partial \phi}{\partial z} p + \frac{\partial \phi}{\partial q} \frac{\partial q}{\partial x}}{\frac{\partial \phi}{\partial p}}$$

$$\text{or } \left(\frac{\partial f}{\partial x} \frac{\partial \phi}{\partial p} - \frac{\partial \phi}{\partial x} \frac{\partial f}{\partial p} \right) + p \left(\frac{\partial f}{\partial z} \frac{\partial \phi}{\partial p} - \frac{\partial \phi}{\partial z} \frac{\partial f}{\partial p} \right) + \frac{\partial q}{\partial y} \left(\frac{\partial f}{\partial q} \frac{\partial \phi}{\partial p} - \frac{\partial \phi}{\partial q} \frac{\partial f}{\partial p} \right) = 0 \quad \dots(4)$$

On eliminating $\frac{\partial q}{\partial y}$ between the equations of second pair, we have

$$\left(\frac{\partial f}{\partial y} \frac{\partial \phi}{\partial q} - \frac{\partial \phi}{\partial y} \frac{\partial f}{\partial q} \right) + q \left(\frac{\partial f}{\partial z} \frac{\partial \phi}{\partial q} - \frac{\partial \phi}{\partial z} \frac{\partial f}{\partial q} \right) + \frac{\partial q}{\partial y} \left(\frac{\partial f}{\partial p} \frac{\partial \phi}{\partial q} - \frac{\partial \phi}{\partial p} \frac{\partial f}{\partial q} \right) = 0 \quad \dots(5)$$

Adding (4) and (5) and keeping in view the relation on, the terms of the last brackets of (4) and (5) cancel. On rearranging, we get

$$\frac{\partial \phi}{\partial f} \left(\frac{\partial f}{\partial x} + p \frac{\partial f}{\partial z} \right) + \frac{\partial \phi}{\partial q} \left(\frac{\partial f}{\partial y} + q \frac{\partial f}{\partial z} \right) + \frac{\partial \phi}{\partial z} \left(-p \frac{\partial f}{\partial p} - q \frac{\partial f}{\partial q} \right) + \left(\frac{-\partial f}{\partial p} \right) \frac{\partial \phi}{\partial x} + \left(\frac{-\partial f}{\partial q} \right) \frac{\partial \phi}{\partial y} = 0$$

$$\text{or } \left(\frac{-\partial f}{\partial p} \right) \frac{\partial \phi}{\partial x} + \left(\frac{-\partial f}{\partial q} \right) \frac{\partial \phi}{\partial y} + \left(-p \frac{\partial f}{\partial p} - q \frac{\partial f}{\partial q} \right) \frac{\partial \phi}{\partial z} + \left(\frac{\partial f}{\partial x} + p \frac{\partial f}{\partial z} \right) \frac{\partial \phi}{\partial p} + \left(\frac{\partial f}{\partial y} + q \frac{\partial f}{\partial z} \right) \frac{\partial \phi}{\partial q} = 0 \quad \dots (6)$$

Equation (6) is a Lagrange's linear equation of the first order with x, y, z, p, q as independent variables and ϕ as dependent variable. Its subsidiary equations are

$$\frac{dx}{-\frac{\partial f}{\partial p}} = \frac{dy}{-\frac{\partial f}{\partial q}} = \frac{dz}{-p \frac{\partial f}{\partial p} - q \frac{\partial f}{\partial q}} = \frac{dp}{\frac{\partial f}{\partial x} + p \frac{\partial f}{\partial z}} = \frac{dq}{\frac{\partial f}{\partial y} + q \frac{\partial f}{\partial z}} = \frac{d\phi}{0} \quad \dots(7)$$

(Commit to memory)

Any of the integrals of (7) satisfies (6). Such an integral involving p or q or both may be taken as assumed relation (3). However, we should choose the simplest integral involving p and q derived from (7). This relation and equation (1) gives the values of p and q . The values of p and q are substituted in (2). On integration new eq. (2) gives the solution of (1).

Example 27. Solve $px + qy = pq$

Solution. $f(x, y, z, p, q) = 0$ is $px + qy - pq = 0 \quad \dots(1)$

Partial Differential Equations

$$\frac{\partial f}{\partial x} = p, \quad \frac{\partial f}{\partial y} = q, \quad \frac{\partial f}{\partial z} = 0, \quad \frac{\partial f}{\partial p} = x - q, \quad \frac{\partial f}{\partial q} = y - p$$

Charpits' equations are

$$\frac{dx}{-\frac{\partial f}{\partial p}} = \frac{dy}{-\frac{\partial f}{\partial q}} = \frac{dz}{-p\frac{\partial f}{\partial p} - q\frac{\partial f}{\partial q}} = \frac{dp}{\frac{\partial f}{\partial x} + p\frac{\partial f}{\partial z}} = \frac{dq}{\frac{\partial f}{\partial y} + q\frac{\partial f}{\partial z}} = \frac{d\phi}{0}$$

$$\frac{dx}{-(x-q)} = \frac{dy}{-(y-p)} = \frac{dz}{-p(x-q) - q(y-p)} = \frac{dp}{p} = \frac{dq}{q} = \frac{d\phi}{0}$$

We have to choose the simplest integral involving p and q

$$\Rightarrow \frac{dp}{p} = \frac{dq}{q} \text{ or } \log p = \log q + \log a \Rightarrow p = aq$$

Putting for p in the given equation (1), we get

$$q(ax + y) = aq^2 \quad \therefore q = \frac{y + ax}{a}$$

$$\therefore p = aq = y + ax$$

$$\text{Now } dz = pdx + qdy \quad \dots(2)$$

Putting for p and q in (2), we get

$$dz = (y + ax)dx + \frac{y + ax}{a}dy$$

$$adz = (y + ax)dx + (y + ax)dy$$

$$adz = (y + ax)(adx + dy)$$

$$az = \frac{(y + ax)^2}{2} + b$$

Integrating

Ans.

Example 28. Solve $(p^2 + q^2)y = qz$(1)

Solution. $f(x, y, z, p, q) = 0$ is $(p^2 + q^2)y - qz = 0$

$$\frac{\partial f}{\partial x} = 0, \quad \frac{\partial f}{\partial y} = p^2 + q^2, \quad \frac{\partial f}{\partial z} = -q, \quad \frac{\partial f}{\partial p} = 2py, \quad \frac{\partial f}{\partial q} = 2qy - z$$

Now Charpits equations are

$$\frac{dx}{-\frac{\partial f}{\partial p}} = \frac{dy}{-\frac{\partial f}{\partial q}} = \frac{dz}{-p\frac{\partial f}{\partial p} - q\frac{\partial f}{\partial q}} = \frac{dp}{\frac{\partial f}{\partial x} + p\frac{\partial f}{\partial z}} = \frac{dq}{\frac{\partial f}{\partial y} + q\frac{\partial f}{\partial z}} = \frac{d\phi}{0}$$

$$\Rightarrow \frac{dx}{-2py} = \frac{dy}{-2q + z} = \frac{dz}{-2p^2y - 2q^2y + qz} = \frac{dp}{-pq} = \frac{dq}{p^2 + q^2 - q^2} = \frac{d\phi}{0}$$

We have to choose the simplest integral involving p and q .

$$\frac{dp}{-pq} = \frac{dq}{p^2} \Rightarrow \frac{dp}{q} = \frac{dq}{p} \Rightarrow pdp + qdp = 0$$

Integrating $p^2 + q^2 = a^2$ (say)

Putting for $p^2 + q^2$ in the equation (1), we get

$$a^2 y = qz \Rightarrow q = \frac{a^2 y}{z} \text{ so } p = \sqrt{a^2 - q^2} = \sqrt{a^2 - \frac{a^4 y^2}{z^2}}$$

$$p = \frac{a}{z} \sqrt{z^2 - a^2 y^2}$$

Partial Differential Equations

Now $dz = p dx + q dy$... (2)

Putting for p and q in (2), we get,

$$dz = \frac{a}{z} \sqrt{z^2 - a^2 y^2} dx + \frac{a^2 y}{z} dy \Rightarrow z dz = a \sqrt{z^2 - a^2 y^2} + a^2 y dy$$

$$\frac{z dz - a^2 y dy}{\sqrt{z^2 - a^2 y^2}} = a dx$$

Integrating, we get, $\frac{1}{2} \frac{2}{1} \sqrt{z^2 - a^2 y^2} = ax + b$

On squaring, $z^2 - a^2 y^2 = (ax + b)^2$ **Ans.**

EXERCISE 9.7

Solve the following:

- | | |
|-------------------------------|--|
| 1. $z = p \cdot q$ | Ans. $2 \sqrt{az} = ax + y + \sqrt{ab}$ |
| 2. $(p + q)(px + qy) - 1 = 0$ | Ans. $z \sqrt{(1+a)} = 2 \sqrt{(ax+y)} + b$ |
| 3. $z = px + qy + p^2 + q^2$ | Ans. $z = ax + by + a^2 + b^2$ |
| 4. $z = p^2 x + q^2 y$ | Ans. $(1+a)z = \left[\sqrt{ax} + \sqrt{(b+y)} \right]^2$ |
| 5. $z^2 = pqxy$ | Ans. $z = ax^b y^{1/b}$ |
| 6. $px + pq + qy = yz$ | Ans. $\log(z - ax) = y - a \log(a + y) + b$ |
| 7. $q + xp = p^2$ | Ans. $z = ax e^{-y} - \frac{1}{2} a^2 e^{-2y} + b$ |

LINEAR HOMOGENEOUS PARTIAL DIFFERENTIAL EQUATIONS OF nTH ORDER WITH CONSTANT COEFFICIENTS

An equation of the type

$$a_0 \frac{\partial^n z}{\partial x^n} + a_1 \frac{\partial^{n-1} z}{\partial x^{n-1} \partial y} + \dots + a_n \frac{\partial^n z}{\partial y^n} = F(x, y) \quad \dots (1)$$

is called a homogeneous linear partial differential equation of nth order with constant coefficients.

It is called homogeneous because all the terms contain derivatives of the same order.

Putting $\frac{\partial}{\partial x} = D$ and $\frac{\partial}{\partial y} = D'$, (1) becomes

$$(a_0 + D^n + a_1 D^{n-1} D' + \dots + a_n D' ^n) z = F(x, y)$$

or $f(D, D') z = F(x, y)$

RULES FOR FINDING THE COMPLEMENTARY FUNCTION

Consider the equation

$$a_0 \frac{\partial^2 z}{\partial x^2} + a_1 \frac{\partial^2 z}{\partial x \partial y} + a_2 \frac{\partial^2 z}{\partial y^2} = 0 \quad \text{or} \quad (a_0 D^2 + a_1 D D' + a_2 D'^2) z = 0$$

1st step : Put $D = m$ and $D' = 1$

$$a_0 m^2 + a_1 m + a_2 = 0$$

This is the auxiliary equation.

2nd step : Solve the auxiliary equation.

Case 1. If the roots of the auxiliary equation are real and different; say m_1, m_2

Then C.F. = $f_1(y + m_1 x) + f_2(y + m_2 x)$.

Partial Differential Equations

Case 2. If the roots are equal; say m

$$\text{Then C.F.} = f_1(y + mx) + xf_2(y + mx)$$

Example 29. Solve $(D^3 - 4D^2 D' + 3D D'^2)z = 0$.

Solution. $(D^3 - 4D^2 D' + 3D D'^2)z = 0$ [$D = m, D' = 1$]

Its auxiliary equation is

$$m^3 - 4m^2 + 3m = 0 \quad \Rightarrow \quad m(m^2 - 4m + 3) = 0$$

$$m(m-1)(m-3) = 0 \quad \Rightarrow \quad m = 0, 1, 3$$

The required solution is $z = f_1(y) + f_2(y+x) + f_3(y+3x)$ **Ans.**

Example 30. Solve $\frac{\partial^2 z}{\partial x^2} - 4\frac{\partial^2 z}{\partial x \partial y} + 4\frac{\partial^2 z}{\partial y^2} = 0$

Solution. $(D^2 - 4D D' + 4D'^2)z = 0$

Its auxiliary equation is [$D = m, D' = 1$]

$$m^2 - 4m + 4 = 0 \quad \Rightarrow \quad (m-2)^2 = 0 \quad \Rightarrow \quad m = 2, 2$$

The required solution is $z = f_1(y+2x) + xf_2(y+2x)$ **Ans.**

EXERCISE 9.8

Solve the following equations :

1. $\frac{\partial^2 z}{\partial x^2} + 4\frac{\partial^2 z}{\partial x \partial y} - \frac{\partial^2 z}{\partial y^2} = 0$

Ans. $z = f_1(y+x) + f_2(y-5x)$

2. $2\frac{\partial^2 z}{\partial x^2} + 5\frac{\partial^2 z}{\partial x \partial y} + 2\frac{\partial^2 z}{\partial y^2} = 0$

Ans. $z = f_1(2y-x) + f_2(y-2x)$

3. $(D^3 - 6D^2 D' + 11D D'^2 - 6D'^3)z = 0$

Ans. $z = f_1(y+x) + f_2(y+2x) + f_3(y+3x)$

4. $\frac{\partial^2 z}{\partial x^2} - 2\frac{\partial^2 z}{\partial x \partial y} + \frac{\partial^2 z}{\partial y^2} = 0$

Ans. $z = f_1(y+x) + xf_2(y+x)$

5. $(D^3 - 6D^2 D' + 12D D'^2 - 8D'^3)z = 0$

Ans. $z = f_1(y+2x) + xf_2(y+2x) + x^2 f_3(y+2x)$

6. $\frac{\partial^4 z}{\partial x^2} - \frac{\partial^4 z}{\partial y^2} = 0$

Ans. $z = f_1(y+x) + f_2(y-x) + f_3(y+ix) + f_4(y-ix)$

7. $\frac{\partial^2 u}{\partial x^2} + \frac{\partial^2 u}{\partial y^2} = 0$, when $u = \sin y, x = 0$ for all y and $u \rightarrow 0$ when $x \rightarrow \infty$.

Ans. $u = f_1(y+ix) + f_2(y-ix)$

9.13. RULES FOR FINDING THE PARTICULAR INTEGRAL

Given partial differential equation is

$$f(D, D')z = F(x, y)$$

$$P.I. = \frac{1}{f(D, D')} F(x, y)$$

(i) When $F(x, y) = e^{ax+by}$

$$P.I. = \frac{1}{f(D, D')} e^{ax+by} = \frac{e^{ax+by}}{f(a, b)} \quad [\text{Put } D = a, D' = b]$$

Partial Differential Equations

(ii) When $F(x,y) = \sin(ax + by)$ or $\cos(ax + by)$

$$P.I. = \frac{1}{f(D^2, DD', D'^2) \sin(ax + by) \text{ or } \cos(ax + by)}$$

$$= \frac{\sin(ax + by) \text{ or } \cos(ax + by)}{f(-a^2, -ab, -b^2)} \quad \left[\begin{array}{l} \text{Put } D^2 = -a^2 \\ DD' = -ab, D'^2 = -b^2 \end{array} \right]$$

(iii) When $F(x,y) = x^m y^n$

$$P.I. = \frac{1}{f(D, D')} x^m y^n = [f(D, D')]^{-1} x^m y^n$$

Expand $[f(D, D')]^{-1}$ in ascending power of D or D' and operate on $x^m y^n$ term by term.

(iv) When = Any function $F(x, y)$

$$P.I. = \frac{1}{f(D, D')} F(x, y)$$

Resolve $\frac{1}{f(D, D')}$ into partial fractions

Considering $f(D, D')$ as a function of D alone

$$P.I. = \frac{1}{D - mD'} F(x, y) = \int F(x, c - mx) dx$$

where c is replaced by $y + mx$ after integration.

Case 1. When R.H. S. = e^{ax+by}

Example 31. Solve : $\frac{\partial^3 z}{\partial x^3} - 3 \frac{\partial^3 z}{\partial x^2 \partial y} + 4 \frac{\partial^3 z}{\partial y^3} = e^{x+2y}$

Solution. $\frac{\partial^3 z}{\partial x^3} - 3 \frac{\partial^3 z}{\partial x^2 \partial y} + 4 \frac{\partial^3 z}{\partial y^3} = e^{x+2y}$

Given equation in symbolic form is

$$(D^3 - 3D^2 D' + 4D'^3)z = e^{x+2y}$$

Its A.E. is $m^3 - 3m^2 + 4 = 0$ whence, $m = -1, 2, 2$.

$$C.F. = f_1(y-x) + f_2(y+2x) + xf_3(y+2x)$$

$$P.I. = \frac{1}{D^3 - 3D^2 D' + 4D'^3} e^{x+2y}$$

Put $D = 1, D' = 2$

$$= \frac{1}{1-6+32} e^{x+2y} = \frac{e^{x+2y}}{27}$$

Hence complete solution is

$$z = f_1(y-x) + f_2(y+2x) + xf_3(y+2x) + \frac{e^{x+2y}}{27}$$

Ans.

EXERCISE 9.9

Solve the following equations:

1. $\frac{\partial^2 z}{\partial x^2} - \frac{\partial^2 z}{\partial y^2} = e^{x+2y}$

Ans. $z = f_1(y+x) + f_2(y-x) - \frac{e^{x+2y}}{3}$

2. $\frac{\partial^2 z}{\partial x^2} - 5 \frac{\partial^2 z}{\partial x \partial y} + 6 \frac{\partial^2 z}{\partial y^2} = e^{x+y}$

Ans. $z = f_1(y+2x) + f_2(y+3x) + \frac{e^{x+y}}{2}$

Partial Differential Equations

3. $\frac{\partial^2 z}{\partial x^2} - 4 \frac{\partial^2 z}{\partial x \partial y} + 4 \frac{\partial^2 z}{\partial y^2} = e^{2x+y}$ **Ans.** $z = f_1(y+2x) + x f_2(y+2x) + \frac{x^2}{2} e^{2x+y}$
4. $\frac{\partial^2 z}{\partial x^2} - 7 \frac{\partial^2 z}{\partial x \partial y} + 12 \frac{\partial^2 z}{\partial y^2} = e^{x-y}$ **Ans.** $z = f_1(y+3x) + f_2(y+4x) + \frac{1}{20} e^{x-y}$
5. $\frac{\partial^2 z}{\partial x^2} - 2 \frac{\partial^2 z}{\partial x \partial y} = 2e^{2x-y}$ **Ans.** $z = f_1(y) + x f_2(y) + f_3(y+2x) + \frac{1}{8} e^{2x-y}$
6. $(D^2 - 2D D' + D'^2)z = e^{x+2y}$ **Ans.** $z = f_1(y+x) + x f_2(y+x) + e^{x+2y}$
7. $\frac{\partial^2 z}{\partial x^2} - \frac{\partial^2 z}{\partial y^2} - 2 \frac{\partial z}{\partial x} + 2 \frac{\partial z}{\partial y} = e^{2x+3y}$ **Ans.** $z = f_1(y+x) + e^{2x} f_2(y-x) - \frac{1}{3} e^{2x+3y}$
8. $\frac{\partial^2 z}{\partial x^2} - 5 \frac{\partial^2 z}{\partial x \partial y} + 6 \frac{\partial z}{\partial y} = \exp(3x-2y)$ **Ans.** $z = f_1(y+2x) + f_2(y+3x) + \frac{1}{63} e^{3x-2y}$

Case II. When R.H.S. = $\sin(ax+by)$ or $\cos(ax+by)$

Example 32. Solve $\frac{\partial^3 z}{\partial x^3} - 4 \frac{\partial^3 z}{\partial x^2 \partial y} + 4 \frac{\partial^3 z}{\partial x \partial y^2} = 2 \sin(3x+2y)$

Solution. $\frac{\partial^3 z}{\partial x^3} - 4 \frac{\partial^3 z}{\partial x^2 \partial y} + 4 \frac{\partial^3 z}{\partial x \partial y^2} = 2 \sin(3x+2y)$
 Putting $\frac{\partial}{\partial x} = D, \frac{\partial}{\partial y} = D'$

$$D^3 z - 4D^2 D' z + 4D D'^2 z = 2 \sin(3x+2y)$$

A.E. is $D^3 - 4D^2 D' + 4D D'^2 = 0 \Rightarrow D(D^2 - 4D D' + 4D'^2) = 0$

Put $D = m, D' = 1$

$$m(m^2 - 4m + 4) = 0 \Rightarrow m(m-2)^2 = 0 \Rightarrow m = 0, 2, 2$$

C.F. is $f_1(y) + f_2(y+2x) + x f_3(y+2x)$

$$\begin{aligned} P.I. &= \frac{1}{D^3 - 4D^2 D' + 4D D'^2} 2 \sin(3x+2y) = 2 \cdot \frac{1}{D(D^2 - 4D D' + 4D'^2)} \sin(3x+2y) \\ &= 2 \cdot \frac{1}{D} \sin(3x+2y) = -\frac{2}{D} \sin(3x+2y) \\ &= -\frac{2}{D} \left[-9 - 4(-6) + 4\left(-\frac{4}{2}\right) \right] \\ &= -\frac{2}{[-\cos(3x+2y)]} = \frac{2}{3} \cos(3x+2y) \end{aligned}$$

General solution is

$$z = f_1(y) + f_2(y+2x) + x f_3(y+2x) + \frac{2}{3} \cos(3x+2y)$$

Ans.

Example 33. Solve $\frac{\partial^2 z}{\partial x^2} - \frac{\partial^2 z}{\partial x \partial y} = \sin x \cos 2y$

Solution. $\frac{\partial^2 z}{\partial x^2} - \frac{\partial^2 z}{\partial x \partial y} = \sin x \cos 2y$

The given equation can be written in the form

$$(D^2 - D D') z = \sin x \cos 2y$$

$$\text{where } D = \frac{\partial}{\partial x}, D' = \frac{\partial}{\partial y}$$

Partial Differential Equations

Writing $D = m$ and $D' = 1$, the auxiliary equation is

$$m^2 - m = 0 \Rightarrow m(m-1) = 0 \Rightarrow m = 0, 1$$

$$C.F. = f_1(y) + f_2(y+x)$$

$$\begin{aligned} P.I. &= \frac{1}{D^2 - DD'} \sin x \cos 2y = \frac{1}{D^2 - DD'} \frac{1}{2} [\sin(x+2y) + \sin(x-2y)] \\ &= \frac{1}{2} \frac{1}{D^2 - DD'} \sin(x+2y) + \frac{1}{2} \frac{1}{D^2 - DD'} \sin(x-2y) \end{aligned}$$

Put $D^2 = -1$, $DD' = -2$ in the first integral and $D^2 = -1$, $DD' = 2$ in the second integral.

$$P.I. = \frac{1}{2} \frac{\sin(x+2y)}{-1 - (-2)} + \frac{1}{2} \frac{\sin(x-2y)}{-1 - (2)} = \frac{1}{2} \sin(x+2y) - \frac{1}{6} \sin(x-2y)$$

Hence the complete solution is $z = C.F. + P.I.$

$$\text{i.e. } z = f_1(y) + f_2(y+x) + \frac{1}{2} \sin(x+2y) - \frac{1}{6} \sin(x-2y)$$

Ans.

Example 34. Solve $(D^2 + DD' - 6D'^2)z = \cos(2x+y)$

Solution. $(D^2 + DD' - 6D'^2)z = \cos(2x+y)$

$$\text{A.E. is } m^2 + m - 6 = 0 \Rightarrow m = 2, -3$$

$$C.F. = f_1(y+2x) + f_2(y-3x)$$

$$P.I. = \frac{1}{D^2 + DD' - 6D'^2} \cos(2x+y)$$

$$D^2 + DD' - 6D'^2 = -4 - 2 - 6(-1) = 0$$

\therefore It is a case of failure.

$$\text{Now } P.I. = \frac{1}{D^2 + DD' - 6D'^2} \cos(2x+y)$$

(Case IV)

$$= x \frac{1}{2D + D'} \cos(2x+y) = x \frac{D}{2D^2 + DD'} \cos(2x+y)$$

$$= x \frac{D}{2(-4) - 2} \cos(2x+y) = -\frac{x}{10} D \cos(2x+y)$$

$$= 2 \frac{x}{10} \sin(2x+y) = \frac{x}{5} \sin(2x+y)$$

$$z = f_1(y+2x) + f_2(y-3x) + \frac{x}{5} \sin(2x+y)$$

Ans.

Example 35. Solve the equation

$$(D^3 - 7DD'^2 - 6D'^3)z = \sin(x+2y) + e^{2x+y}$$

Solution $(D^3 - 7DD'^2 - 6D'^3)z = \sin(x+2y) + e^{2x+y}$

...(1)

Its auxiliary equation is

$$m^3 - 7m - 6 = 0 \Rightarrow (m+1)(m+2)(m-3) = 0 \Rightarrow m = -1, -2, 3$$

$$C.F. = f_1(y-x) + f_2(y-2x) + f_3(y+3x)$$

$$P.I. = \frac{1}{D^3 - 7DD'^2 - 6D'^3} [\sin(x+2y) + e^{2x+y}]$$

Partial Differential Equations

$$\begin{aligned}
&= \frac{1}{D^3 - 7DD'^2 - 6D'^3} \sin(x+2y) + \frac{1}{D^3 - 7DD'^2 - 6D'^3} e^{2x+y} \\
&= \frac{1}{D^2 \cdot D - 7DD'^2 - 6D'^2 D'} \sin(x+2y) + \frac{1}{(2)^3 - 7(2)(1)^2 - 6(1)^3} e^{2x+y} \\
\text{Put } D^2 &= -1, D'^2 = -2^2 \\
&= \frac{1}{-D - 7D(-4) - 6(-4)D'} \sin(x+2y) + \frac{1}{8-14-6} e^{2x+y} \\
&= \frac{1}{27D + 24D'} \sin(x+2y) - \frac{1}{12} e^{2x+y} = \frac{1}{3 \cdot 9D + 8D'} \sin(x+2y) - \frac{1}{12} e^{2x+y} \\
&= \frac{1}{3 \cdot 9D^2 + 8DD'} \sin(x+2y) - \frac{1}{12} e^{2x+y} = \frac{1}{3 \cdot 9(-1) + 8(-2)} \sin(x+2y) - \frac{1}{12} e^{2x+y} \\
&= -\frac{1}{75} D \sin(x+2y) - \frac{1}{12} e^{2x+y} = -\frac{1}{75} \cos(x+2y) - \frac{1}{12} e^{2x+y}
\end{aligned}$$

Hence the complete solution is

$$z = f_1(y-x) + f_2(y-2x) + f_3(y+3x) - \frac{1}{75} \cos(x+2y) - \frac{1}{12} e^{2x+y} \quad \text{Ans.}$$

EXERCISE 9.10

Solve the following equations :

- $\frac{\partial^2 z}{\partial x^2} - 2 \frac{\partial^2 z}{\partial x \partial y} + \frac{\partial^2 z}{\partial y^2} = \sin x$ Ans. $z = f_1(y+x) + x f_2(y+x) - \sin x$
- $[2D^2 - 5DD' + 2D'^2] z = 5 \sin(2x+y)$ Ans. $z = f_1(y+2x) + f_2(2y+x) - \frac{5}{3} x \cos(2x+y)$
- $\frac{\partial^2 z}{\partial x^2} - \frac{\partial^2 z}{\partial x \partial y} = \cos(x+2y)$ Ans. $z = f_1(y) + f_2(y+x) + \cos(x+2y)$
- $(D^2 - DD') z = \cos x \cos 2y$ Ans. $z = f_1(y) + f_2(y+x) + \frac{1}{2} \cos(x+2y) - \frac{1}{6} \cos(x-2y)$
- $(D^2 + 2DD' + D'^2) z = \sin(x+2y)$ Ans. $z = f_1(y-x) + x f_2(y-x) - \frac{1}{9} \sin(x+2y)$
- $\frac{\partial^2 z}{\partial x^2} - 3 \frac{\partial^2 z}{\partial x \partial y} + 2 \frac{\partial^2 z}{\partial y^2} = e^{2x+3y} + \sin(x+2y)$ Ans. $z = c f_1(y+x) + f_2(y+2x) + \frac{1}{4} e^{2x+3y} - \frac{1}{15} \sin(x-2y)$

Case III. When R.H.S. = $x^m y^n$

Example 36. Find the general integral of the equation

$$\frac{\partial^2 z}{\partial x^2} + 3 \frac{\partial^2 z}{\partial x \partial y} + 2 \frac{\partial^2 z}{\partial y^2} = x+y$$

Solution. $\frac{\partial^2 z}{\partial x^2} + 3 \frac{\partial^2 z}{\partial x \partial y} + 2 \frac{\partial^2 z}{\partial y^2} = x+y$

with $D = \frac{\partial}{\partial x}, D' = \frac{\partial}{\partial y}$, the given equation can be written in the form

$$(D^2 + 3DD' + 2D'^2) z = x+y$$

Writing $D = m$ and $D' = 1$, the auxiliary equation is

$$m^2 + 3m + 2 = 0 \Rightarrow (m+1)(m+2) = 0 \Rightarrow m = -1, -2$$

Partial Differential Equations

$$\therefore \text{C.F.} = f_1(y-x) + f_2(y-2x)$$

$$\begin{aligned} \text{P.I.} &= \frac{1}{D^2 + 3DD' + 2D'^2}(x+y) \\ &= \frac{1}{D^2} \left(1 + \frac{3D'}{D} + \frac{2D'^2}{D^2} \right)^{-1} (x+y) = \frac{1}{D^2} \left(1 - \frac{3D'}{D} + \dots \right) (x+y) \\ &= \frac{1}{D^2} \left(x+y - 3 \frac{1}{D}(1) \right) = \frac{1}{D^2} [x+y-3x] \\ &= \frac{1}{D^2} [y-2x] = \frac{x^2}{2} y - \frac{x^3}{3} \end{aligned}$$

Hence the complete solution is $z = f_1(y-x) + f_2(y-2x) + \frac{x^2 y}{2} - \frac{x^3}{3}$

Ans.

Example 37. Solve $\frac{\partial^2 z}{\partial x^2} + \frac{\partial^2 z}{\partial x \partial y} - \frac{\partial^2 z}{\partial y^2} = x + y$

Solution. With $D = \frac{\partial}{\partial x}$, $D' = \frac{\partial}{\partial y}$, the given equation can be written in the form

$$(D^2 + DD' - 6D'^2)z = x + y$$

Writing $D = m$ and $D' = 1$, the auxiliary equation is $m^2 + m - 6 = 0$

$$\Rightarrow (m+3)(m-2) = 0 \Rightarrow m = -3, 2$$

$$\therefore \text{C.F.} = f_1(y-3x) + f_2(y+2x)$$

$$\begin{aligned} \therefore \text{P.I.} &= \frac{1}{D^2 + DD' - 6D'^2}(x+y) \\ &= \frac{1}{D^2} \left(1 + \frac{D'}{D} - \frac{6D'^2}{D^2} \right)^{-1} (x+y) = \frac{1}{D^2} \left[1 - \frac{D'}{D} + \dots \right] (x+y) \\ &= \frac{1}{D^2} \left(x+y - \frac{1}{D}(1) \right) = \frac{1}{D^2} (x+y-x) = \frac{1}{D^2} y = \frac{yx^2}{2} \end{aligned}$$

The complete solution is

$$z = f_1(y-3x) + f_2(y+2x) + \frac{yx^2}{2}$$

Ans.

Example 38. Solve $\frac{\partial^3 z}{\partial x^3} - 2 \frac{\partial^3 z}{\partial x^2 \partial y} = 2e^{2x} + 3x^2 y$ (A.M.I.E., Summer 2004, 2001)

Solution. $\frac{\partial^3 z}{\partial x^3} - 2 \frac{\partial^3 z}{\partial x^2 \partial y} = 2e^{2x} + 3x^2 y$

$$\Rightarrow (D^3 - 2D^2 D')z = 2e^{2x} + 3x^2 y$$

Its auxiliary equation is

$$\begin{aligned} m^3 - 2m^2 &= 0 \\ \Rightarrow m^2(m-2) &= 0 \\ \Rightarrow m &= 0, 0, 2. \end{aligned}$$

$$\text{C.F.} = f_1(y) + x f_2(y) + f_3(y+2x)$$

$$\text{P.I.} = \frac{1}{D^3 - 2D^2 D'}(2e^{2x} + 3x^2 y)$$

Partial Differential Equations

$$\begin{aligned}
&= \frac{1}{D^3 - 2D^2D'} 2e^{2x} + \frac{1}{D^3 - 2D^2D'} 3x^2y \\
&= 2 \frac{e^{2x}}{(2)^3 - 2(2)^2(0)} + 3 \frac{1}{D \left(1 - \frac{2D'}{D}\right)} x^2y = \frac{2e^{2x}}{8} + \frac{3 \left(1 - \frac{2D'}{D}\right)^{-1} x^2y}{D^3} \\
&= \frac{e^{2x}}{4} + \frac{3 \left(1 - \frac{2D'}{D}\right)^{-1} x^2y}{D^3} = \frac{e^{2x}}{4} + \frac{3 \left[x^2y + \frac{2x^3}{3} \right]}{D^3} \\
&= \frac{e^{2x}}{4} + 3y \frac{1}{D^3} x^2 + \frac{2}{D^3} x^3 = \frac{e^{2x}}{4} + 3y \frac{x^5}{3 \cdot 4 \cdot 5} + 2 \frac{x^6}{4 \cdot 5 \cdot 6} = \frac{e^{2x}}{4} + \frac{x^5y}{20} + \frac{x^6}{60} \\
&= \frac{1}{60} (15e^{2x} + 3x^5y + x^6)
\end{aligned}$$

Hence the complete solution is

$$z = f_1(y) + xf_2(y) + f_3(y + 2x) + \frac{1}{60} (15e^{2x} + 3x^5y + x^6) \quad \text{Ans.}$$

EXERCISE 9.11

Solve the following equations :

$$1. \frac{\partial^2 z}{\partial x^2} - \frac{\partial^2 z}{\partial y^2} = x - y$$

$$\text{Ans. } z = f_1(y - x) + f_2(y + x) + \frac{x^3}{6} - \frac{x^2y}{2}$$

(A.M.I.E., Winter 2001)

$$2. \frac{\partial^2 z}{\partial x^2} + \frac{\partial^2 z}{\partial x \partial y} + \frac{\partial^2 z}{\partial y^2} = 12xy$$

$$\text{Ans. } z = f_1(y - x) + f_2(y - 2x) + 2x^3y - \frac{3x^4}{2}$$

$$3. \frac{\partial^2 z}{\partial x^2} - \frac{\partial^2 z}{\partial x \partial y} - 6 \frac{\partial^2 z}{\partial y^2} = xy$$

$$\text{Ans. } z = f_1(y - 2x) + f_2(y + 3x) + \frac{x^3y}{6} + \frac{x^4}{24}$$

$$4. r + 2s + t = 2(y - x) + \sin(x - y)$$

$$\text{Ans. } z = f_1(y - x) + xf_2(y - x) + x^2y - x^3 + \frac{x^2}{2} \sin(x - y)$$

$$5. \frac{\partial^2 z}{\partial x^2} - a^2 \frac{\partial^2 z}{\partial y^2} = x^2$$

$$\text{Ans. } z = f_1(y + ax) + f_2(y - ax) + \frac{x^4}{12}$$

$$6. \frac{\partial^2 z}{\partial x^2} - 2 \frac{\partial^2 z}{\partial x \partial y} + \frac{\partial^2 z}{\partial y^2} = x^2 + y$$

$$\text{Ans. } z = f_1(y + x) + xf_2(y + x) + \frac{x^3}{12} + \frac{xy}{2} + \frac{y^3}{3}$$

$$7. \frac{\partial^2 z}{\partial x^2} + \frac{\partial^2 z}{3 \partial x \partial y} - 4 \frac{\partial^2 z}{\partial y^2} = x + \sin y$$

$$\text{Ans. } z = f_1(y + x) + f_2(y - 4x) + \frac{x}{6} + \frac{1}{4} \sin y$$

$$8. (D^3 - 3D^2D') z = x^2y$$

$$\text{Ans. } z = f_1(y) + xf_2(y) + f_3(y + 3x) + \frac{x^5y}{60} + \frac{x^6}{120}$$

Case IV. When R.H.S. = Any function

Example 39. Solve $(D^2 - DD' - 2D'^2)z = (y - 1)e^x$

Solution. $(D^2 - DD' - 2D'^2)z = (y - 1)e^x$

$$\text{A.E. is } D^2 - DD' - 2D'^2 = 0 \Rightarrow m^2 - m - 2 = 0$$

$$\Rightarrow (m - 2)(m + 1) = 0 \Rightarrow m = 2, -1$$

$$\text{C.F.} = f_1(y + 2x) + f_2(y - x)$$

$$\text{P.I.} = \frac{1}{D^2 - DD' - 2D'^2} (y - 1)e^x$$

Partial Differential Equations

$$\begin{aligned}
 &= \frac{1}{(D+D')(D-2D')}(y-1)e^x = \frac{1}{D+D'} \int [(c-2x-1)e^x dx] && \text{[Put } y = c - 2x\text{]} \\
 &= \frac{1}{D+D'} [(c-2x-1)e^x + 2e^x] \\
 &= \frac{1}{D+D'} [ce^x - 2xe^x + e^x] && \text{[Put } c = y + 2x\text{]} \\
 &= \frac{1}{D+D'} [(y+2x)e^x - 2xe^x + e^x] = \frac{1}{D+D'} [ye^x + e^x] \\
 &= \int [(c+x)e^x + e^x] dx && \text{[Put } y = c + x\text{]} \\
 &= (c+x)e^x - e^x + e^x \\
 &= ce^x + xe^x = (y-x)e^x + xe^x && \text{[Put } c = y - x\text{]} \\
 &= ye^x
 \end{aligned}$$

Hence complete solution is $z = f_1(y+2x) + f_2(y-x) + ye^x$

Ans.

Example 40. Solve $\frac{\partial^2 z}{\partial x^2} + \frac{\partial^2 z}{\partial x \partial y} - \frac{\partial^2 z}{\partial y^2} = y \cos x$

Solution. $\frac{\partial^2 z}{\partial x^2} + \frac{\partial^2 z}{\partial x \partial y} - \frac{\partial^2 z}{\partial y^2} = y \cos x$

$$(D^2 + DD' - 6D'^2)z = y \cos x$$

Its auxiliary equation is $m^2 + m - 6 = 0$

$$(m+3)(m-2) = 0$$

$$m = 2, -3$$

$$\text{C.F.} = f_1(y+2x) + f_2(y-3x)$$

$$\text{P.I.} = \frac{1}{D^2 + DD' - 6D'^2} y \cos x = \frac{1}{(D-2D')(D+3D')} y \cos x$$

$$= \frac{1}{D-2D'} \int (c+3x) \cos x dx \quad \text{Put } y = c + 3x$$

$$= \frac{1}{D-2D'} [(c+3x) \sin x + 3 \cos x] = \frac{1}{D-2D'} [y \sin x + 3 \cos x] \quad \text{Put } c + 3x = y$$

$$= \int [(c-2x) \sin x + 3 \cos x] dx \quad \text{Put } y = c - 2x$$

$$= (c-2x)(-\cos x) - 2 \sin x + 3 \sin x = -y \cos x + \sin x \quad \text{Put } c - 2x = y$$

Hence the complete solution is

$$z = f_1(y+2x) + f_2(y-3x) + \sin x - y \cos x \quad \text{Ans.}$$

EXERCISE 9.12

Solve the following equations:

1. $(D-D')(D+2D')z = (y+1)e^x$

Ans. $z = f_1(y+x) + f_2(y-2x) + ye^x$

2. $\frac{\partial^2 z}{\partial x^2} - \frac{\partial^2 z}{\partial y^2} = \tan^3 x \tan y - \tan x \tan^3 y$

Ans. $z = f_1(y+x) + f_2(x-y) + \frac{1}{2} \tan x \tan y$

3. $(D^2 - DD' - 2D'^2)z = (2x^2 + xy - y^2) \sin xy - \cos xy$ **Ans.** $z = f_1(y+2x) + f_2(y-x) + \sin xy$

4. Tick ✓ the correct answer :

- (a) The solution of $\frac{\partial^3 z}{\partial x^3} = 0$ is
- (i) $z = f_1(y) + xf_2(y) + x^2f_3(y)$ (ii) $z = (1 + x + x^2)f(y)$
 (iii) $z = f_1(x) + yf_2(x) + y^2f_3(x)$ (iv) $z = (1 + y + y^2)f(x)$
- (b) The solution of $\frac{\partial^2 z}{\partial x^2} - \frac{\partial^2 z}{\partial y^2} = 0$ is
- (i) $z = f_1(y + x) + f_1(y - x)$ (ii) $z = f_1(y + x) + f_2(y - x)$
 (iii) $z = f_2(y + x) + f_2(y - x)$ (iv) $z = f(x^2 - y^2)$
- (c) Particular integral of $(2D^2 - 3DD' + D'^2)z = e^{x+2y}$ is
- (i) xe^{x+2y} (ii) $\frac{1}{2}e^{x+2y}$ (iii) $-\frac{x}{2}e^{x+2y}$ (iv) $\frac{x^2}{2}e^{x+2y}$
- (d) Particular integral of $(D^2 - D'^2)z = \cos(x + y)$ is
- (i) $\frac{x}{2}\cos(x + y)$ (ii) $x\sin(x + y)$ (iii) $x\cos(x + y)$ (iv) $\frac{x}{2}\sin(x + y)$

Ans. (a) (i), (b) (ii), (c) (iii), (d) (iv).

9.14 NON-HOMOGENEOUS LINEAR EQUATIONS

The linear differential equations which are not homogeneous are called Non-homogeneous Linear Equations.

For example,

$$3\frac{\partial^2 z}{\partial x^2} + 2\frac{\partial^2 z}{\partial x\partial y} + 4\frac{\partial^2 z}{\partial y^2} + 5\frac{\partial z}{\partial x} + \frac{\partial z}{\partial y} + z = 0$$

$$f(D, D') = f_1(x, y)$$

Its solution,

$$z = \text{C.F.} + \text{P.I.}$$

Complementary Function: Let the non-homogeneous equation be

$$(D - mD' - a)z = 0 \Rightarrow \frac{\partial z}{\partial x} - m\frac{\partial z}{\partial y} - az = 0$$

$$p - mq = az$$

The Lagrange's subsidiary equations are

$$\frac{dx}{1} = \frac{dy}{-m} = \frac{dz}{az}$$

From first two relations we have, $-mdx = dy$

$$dy + mdx = 0 \Rightarrow y + mx = c_1 \quad \dots (1)$$

$$\text{and from first and third relation, } dx = \frac{dz}{az} \Rightarrow x = \frac{1}{a} \log z + c \Rightarrow z = c e^{ax} \quad \dots (2)$$

From (1) and (2), we have $z = e^{ax} \phi(y + mx)$

Similarly the solution of $(D - mD' - a)^2 Z = 0$ is

$$z = e^{ax}\phi_1(y + mx) + xe^{ax}\phi_2(y + mx)$$

Example 41. Solve $(D + D' - 2)(D + 4D' - 3)z = 0$

Solution. The equation can be rewritten as $\{D - (-D)' - 2\}\{D - (-4D') - 3\}z = 0$

Partial Differential Equations

Hence the solution is

$$z = e^{2x} \phi_1(y - mx) + e^{3x} \phi_2(y - 4mx)$$

Ans.

Example 42. Solve $(D + 3D' + 4)^2 z = 0$

Solution. The equation is rewritten as

$$[D - (-3D') - (-4)]^2 z = 0$$

Hence the solution is

$$z = e^{-4x} \phi_1(y - 3x) + x e^{-4x} \phi_2(y - 3x)$$

Ans.

Example 43. Solve $r + 2s + t + 2p + 2q + z = 0$

Solution. The equation is rewritten as

$$(D^2 + 2DD' + D^2 + 2D + 2D' + 1)z = 0$$

$$\Rightarrow [(D + D')^2 + 2(D + D') + 1]z = 0$$

$$\Rightarrow (D + D' + 1)^2 z = 0$$

$$\Rightarrow [D - (-D') - (-1)]^2 z = 0$$

Hence the solution is

$$z = e^{-x} \phi_1(y - x) + x e^{-x} \phi_2(y - x)$$

Example 44. Solve $r - t + p - q = 0$

Solution. The equation is rewritten as

$$(D^2 - D'^2 + D - D')z = 0$$

$$\Rightarrow [(D - D')(D + D') + 1(D - D')]z = 0$$

$$\Rightarrow (D - D')(D + D' + 1)z = 0$$

Hence the solution is

$$z = \phi_1(y + x) + e^{-x} \phi_2(y - x)$$

Ans.

Particular Integral

Case 1. $\frac{1}{F(D, D')} e^{ax+by} = \frac{1}{F(a, b)} e^{ax+by}$

Example 45. Solve $(D - D' - 2)(D - D' - 3)z = e^{3x-2y}$

The complementary function is

$$\text{P.I.} = \frac{e^{2x} \phi_1(y+x) + e^{3x} \phi_2(y+x)}{(D - D' - 2)(D - D' - 3)} e^{3x-2y} = \frac{1}{[3 - (-2) - 2][3 - (-2) - 3]} e^{3x-2y} = \frac{1}{6} e^{3x-2y}$$

Hence the complete solution is

$$z = e^{2x} \phi_1(y+x) + e^{3x} \phi_2(y+x) + \frac{1}{6} e^{3x-2y}$$

Ans.

Case 2. $\frac{1}{F(D^2, DD', D'^2)} \sin(ax+by) = \frac{1}{F(-a^2, -ab, -b^2)} \sin(ax+by)$

Example 46. Solve $(D + 1)(D + D' - 1)z = \sin(x + 2y)$

Solution. C.F. = $e^{-x} \phi_1(y) + e^{-x} \phi_2(y - x)$

$$\text{P.I.} = \frac{1}{(D+1)(D+D'-1)} \sin(x+2y) = \frac{1}{D^2 + DD' + D' - 1} \sin(x+2y)$$

Partial Differential Equations

$$\begin{aligned}
 &= \frac{1}{-1+(-2)+D'-1} \sin(x+2y) = \frac{1}{D'-4} \sin(x+2y) \\
 &= \frac{D'+4}{(D'^2-16)} \sin(x+2y) = \frac{D'+4}{(-4-16)} \sin(x+2y) \\
 &= -\frac{1}{20}(D'+4)\sin(x+2y) = -\frac{1}{20}[D'\sin(x+2y)+4\sin(x+2y)] \\
 &= -\frac{1}{20}[2\cos(x+2y)+4\sin(x+2y)]
 \end{aligned}$$

Hence, the solution is $z = e^{-x}\phi_1(y) + e^{-x}\phi_2(y-x) - \frac{1}{10}[\cos(x+2y) + 2\sin(x+2y)]$ **Ans.**

Case 3. $\frac{1}{F(D, D')} x^m y^n = [F(D, D')]^{-1} x^m y^n$

Example 47. Solve $[D^2 - D'^2 + D + 3D' - 2]z = x^2 y$

Solution. $(D - D' + 2)(D + D' - 1)z = 0$

C.F. = $e^{-2x}\phi_1(y+x) + e^x\phi_2(y-x)$

P.I. = $\frac{1}{(D - D' + 2)(D + D' - 1)} x^2 y$

$$= \frac{1}{D^2 - D'^2 + D + 3D' - 2} x^2 y = -\frac{1}{2} \frac{1}{3D' - D} \frac{1}{D^2 - D'^2} x^2 y$$

$$= -\frac{1}{2} \left[1 - \frac{1}{3D' + D - D'^2} + D^2 \right]^{-1} x^2 y$$

$$= -\frac{1}{2} \left[\frac{1}{3D' + D - D'^2 + D^2} + \frac{1}{(3D' + D - D'^2 + D^2)^2} \right] x^2 y$$

$$= -\frac{1}{2} \left[\frac{1}{2} + \frac{1}{4} (3D' + D - D'^2 + D^2)^2 + \frac{1}{8} (3D' + D - D'^2 + D^2)^3 \right] x^2 y$$

$$= -\frac{1}{2} \left[1 + \frac{1}{2} (3D' + D - D'^2 + D^2) + \frac{1}{4} (9D'^2 + D^2 + 6DD' + 6D^2D') + \frac{1}{8} (9D^2D') \right] x^2 y$$

$$= -\frac{1}{2} \left[x^2 y + \frac{1}{4} (3x^2 + 2xy - 0 + 2y) + \frac{1}{4} (0 + 2y + 12x + 12) + \frac{1}{8} (18) \right] x^2 y$$

$$= -\frac{1}{2} \left[x^2 y + \frac{3x^2}{2} + xy + y + \frac{4}{2} y + 3x + 3 + \frac{9}{4} \right] = -\frac{1}{2} \left(x^2 y + \frac{3x^2}{2} + xy + \frac{4y}{2} + 3x + \frac{9}{4} \right)$$

Hence the complete solution is

$$z = e^{-2x} \phi_1(y+x) + e^x \phi_2(y-x) - \frac{1}{2} \left(x^2 y + \frac{3x^2}{2} + xy + \frac{4y}{2} + 3x + \frac{9}{4} \right)$$
 Ans.

Case 4. $\frac{1}{F(D, D')} [e^{ax+by}\phi(x, y)] = e^{ax+by} \frac{1}{F(D+a, D'+b)} \phi(x, y)$

Partial Differential Equations

Example 48. Solve $(D - 3D' - 2)^2 z = 2e^{2x} \sin(y + 3x)$

Solution. A.E.is $(D - 3D' - 2)^2 = 0$

$$\text{C.F.} = e^{2x}\phi_1(y + 3x) + x e^{2x}\phi_2(y + 3x)$$

$$\text{P.I.} = \frac{2e^{2x} \cdot \sin(y + 3x)}{(D - 3D' - 2)^2}$$

$$= 2e^{2x} \frac{1}{(D + 2 - 3D' - 2)^2} \sin(y + 3x) = 2e^{2x} \frac{1}{(D - 3D')^2} \sin(y + 3x)$$

$$= 2e^{2x} \cdot x \frac{1}{2(D - 3D')} \sin(y + 3x) \quad (\text{As denominator becomes zero})$$

$$= 2x^2 e^{2x} \frac{1}{2} \sin(y + 3x) \quad (\text{Again differentiate})$$

$$= x^2 e^{2x} \sin(y + 3x)$$

Hence the complete solution is

$$z = e^{2x}\phi(y + 3x) + x e^{2x}\phi_2(y + 3x) + x^2 e^{2x} \sin(y + 3x) \quad \text{Ans.}$$

Example 49. Solve $(D^2 + DD' - 6D'^2)z = x^2 \sin(x + y)$

Solution. $(D^2 + DD' - 6D'^2)z = x^2 \sin(x + y)$

For complementary function

$$(D^2 + DD' - 6D'^2) = 0 \Rightarrow (D - 2D')(D + 3D') = 0$$

$$\text{C.F.} = \phi_1(y + 2x) + \phi_2(y - 3x)$$

$$\text{P.I.} = \frac{1}{D - DD' - 6D'^2} x^2 \sin(x + y)$$

$$= \text{Imaginary part of } \frac{1}{D^2 - DD' - 6D'^2} x^2 [\cos(x + y) + i \sin(x + y)]$$

$$= \text{Imaginary part of } \frac{1}{D^2 - DD' - 6D'^2} x^2 e^{i(x+y)} = \text{Imaginary part of } e^{iy} \frac{1}{D^2 - Di - 6(i)^2} x^2 e^{ix}$$

$$= \text{Imaginary part of } e^{i(x+y)} \frac{1}{(D+i)^2 + (D+i)i + 6} x^2$$

$$= \text{Imaginary part of } e^{i(x+y)} \frac{1}{D^2 + 3iD + 4} x^2 = \text{Imaginary part of } \frac{e^{i(x+y)}}{4} \frac{1}{1 + \frac{3iD}{4} + \frac{D^2}{4}} x^2$$

$$= \text{Imaginary part of } \frac{e^{i(x+y)}}{4} \left[1 + \frac{3iD}{4} + \frac{D^2}{4} \right]^{-1} x^2$$

$$= \text{Imaginary part of } \frac{e^{i(x+y)}}{4} \left[1 - \frac{3iD}{4} - \frac{D^2}{4} + \frac{9D^2}{16} \dots \right] x^2$$

$$= \text{Imaginary part of } \frac{e^{i(x+y)}}{4} \left[x^2 - \frac{3ix}{2} - \frac{2}{4} - \frac{9}{16} (2) \right]$$

$$= \text{Imaginary part of } \frac{1}{4} \left[\cos(x + y) + i \sin(x + y) \right] \left[x^2 - \frac{3ix}{2} - \frac{13}{8} \right]$$

$$= \frac{1}{4} \left[\sin(x+y) \left(x^2 - \frac{13}{8} \right) - \frac{3}{2} x \cos(x+y) \right] = \frac{1}{4} \sin(x+y) \left(x^2 - \frac{13}{8} \right) - \frac{3x}{8} \cos(x+y)$$

Hence, the complete solution is

$$z = \phi_1(y+2x) + \phi_2(y-3x) + \frac{1}{4} \sin(x+y) \left(x^2 - \frac{13}{8} \right) - \frac{3x}{8} \cos(x+y) \quad \text{Ans.}$$

EXERCISE 9.13

Solve the following equations:

1. $(D^2 + 2DD' + D'^2 - 2D - 2D')z = 0$. **Ans.** $z = f_1(x-y) + e^{2x}f_2(x-y)$

2. $(D^2 - D'^2 - 3D + 3D')z = e^{x-2y}$ **Ans.** $z = \phi_1(y+x) + e^{3x}\phi_2(y-x) - \frac{1}{12}e^{x-2y}$

3. $(D - D' - 1)(D + D' - 2)z = e^{2x-y}$ **Ans.** $z = e^x\phi_1(x+y) + e^{2x}\phi_2(y-x) - \frac{1}{2}e^{2x-y}$

4. $(D^2 - D'^2 - 3D + 3D')z = e^{x+2y}$ **Ans.** $z = \phi_1(y+x) + e^{3x}\phi_2(x-y) - xe^{x+2y}$

5. $(D + D')(D + D' - 2)z = \sin(x+2y)$

$$\text{Ans. } z = \phi_1(y-x) + e^{2x}(y-x) + \frac{1}{117} [6 \cos(x+2y) - 9 \sin(x+2y)]$$

6. $(D^2 - DD' - 2D)z = \cos(3x+4y)$

$$\text{Ans. } z = \phi_1(y) + e^{2x}\phi_2(y+x) + \frac{1}{15} [\cos(3x+4y) - 2 \sin(3x+4y)]$$

7. $(DD' + D - D' - 1)z = xy$ **Ans.** $z = e^{-y}\phi_1(x) + e^x\phi_2(y) - (xy + y - x - 1)$

8. $(D + D' - 1)(D + 2D' - 3)z = 4 + 3x + 6y$ **Ans.** $z = e^x\phi_1(x-y) + e^{3x}\phi_2(2x-y) + 6 + x + 2y$

9. $\frac{\partial^2 z}{\partial x^2} - \frac{\partial^2 z}{\partial y^2} - 3\frac{\partial z}{\partial x} + 3\frac{\partial z}{\partial y} = xy + e^{x+2y}$ (UP. HI Semester, Summer 2002)

$$\text{Ans. } z = f_1(y+x) + e^{3x}f_2(y-x) - \frac{1}{3} \left(\frac{x^2 y}{3} + \frac{x^3}{6} + \frac{x^2}{3} + \frac{xy}{3} + \frac{2x}{9} \right) - xe^{2x-y}$$

10. $(D - D' - 1)(D - D' - 2)z = e^{2x-y}$ **Ans.** $z = e^x f_1(y+x) + e^{2x} f_2(y+x) + \frac{1}{2} e^{2x-y}$

11. $D(D + D' - 1)(D + 3D' - 2)z = x^2 - 4xy + 2y^2$

$$\text{Ans. } z = \phi_1(y) + e^x \phi_2(x-y) + e^{2x} \phi_3(3x-y) + \frac{1}{2} \left[\frac{x^3}{3} - 2x^2 y + 2xy^2 - \frac{7}{2} x^2 + 4xy + \frac{x}{2} \right]$$

12. $(D - D' + 2)(D + D' - 1)z = e^{x-y} - x^2 y$

$$\text{Ans. } z = e^{2y} \phi_1(x+y) e^x \phi_2(x-y) - \frac{e^{x-y}}{4} + \frac{1}{2} \left[x^2 y + xy + \frac{3x^2}{2} + \frac{3}{2} y + 3x + \frac{21}{4} \right]$$

13. $(D^2 - DD' - 2D'^2 + 2D' + 2D)z = e^{2x+3y} + \sin(2x+y) + xy$

$$\text{Ans. } z = \phi_1(x-y) + e^y \phi_2(2x+y) - \frac{1}{10} e^{2x+3y} - \frac{1}{6} \cos(2x+y) + \frac{x}{24} (6xy - 6y + 9x - 2x^2 - 12)$$

UNIT-3

Laplace Transformation

INTRODUCTION

Laplace transforms help in solving the differential equations with boundary values without finding the general solution and the values of the arbitrary constants.

LAPLACE TRANSFORM

Definition. Let $f(t)$ be function defined for all positive values of t , then

$$F(s) = \int_0^{\infty} e^{-st} f(t) dt$$

provided the integral exists, is called the **Laplace Transform** of $f(t)$. It is denoted as

$$L[f(t)] = F(s) = \int_0^{\infty} e^{-st} f(t) dt$$

IMPORTANT FORMULAE

- | | |
|--|--|
| <p>1. $L(1) = \frac{1}{s}$</p> <p>3. $L(e^{at}) = \frac{1}{s-a} \quad (s > a)$</p> <p>5. $L(\sinh at) = \frac{a}{s^2 - a^2} \quad (s^2 > a^2)$</p> <p>7. $L(\cos at) = \frac{s}{s^2 + a^2} \quad (s > 0)$</p> | <p>2. $L(t^n) = \frac{n!}{s^{n+1}}$, when $n = 0, 1, 2, 3, \dots$</p> <p>4. $L(\cosh at) = \frac{s}{s^2 - a^2} \quad (s > a)$</p> <p>6. $L(\sin at) = \frac{a}{s^2 + a^2} \quad (s > 0)$</p> |
|--|--|

1. $L(1) = \frac{1}{s}$

Proof. $L(1) = \int_0^{\infty} 1 \cdot e^{-st} dt = \left[\frac{e^{-st}}{-s} \right]_0^{\infty} = -\frac{1}{s} \left[\frac{1}{e} \right]_0^{\infty} = -\frac{1}{s} [0 - 1] = \frac{1}{s}$

Hence $L(1) = \frac{1}{s}$

Proved.

2. $L(t^n) = \frac{n!}{s^{n+1}}$ where n and s are positive.

Proof. $L(t^n) = \int_0^{\infty} e^{-st} t^n dt$

Putting $st = x \Rightarrow t = \frac{x}{s} \Rightarrow dt = \frac{dx}{s}$

LET YOUR LIGHT SHINE

Thus, we have $L(t^n) = \int_0^{\infty} \frac{e^{-sx} (x)^n dx}{n!} \Rightarrow L(t^n) = \frac{1}{s^{n+1}} \int_0^{\infty} e^{-x} x^n dx$

$\Rightarrow L(t^n) = \frac{n+1}{s^{n+1}} \Rightarrow L(t^n) = \frac{1}{s^{n+1}}$ and $\begin{cases} n+1 = \int_0^{\infty} e^{-x} x^n dx \\ n+1 = n! \end{cases}$ **Proved.**

3. $L(e^{at}) = \frac{1}{s-a}$, where $s > a$

Proof. $L(e^{at}) = \int_0^{\infty} e^{-st} \cdot e^{at} dt = \int_0^{\infty} e^{-st+at} dt$

$= \int_0^{\infty} e^{-(s-a)t} dt = \int_0^{\infty} e^{-\frac{(s-a)t}{1}} dt = \left[\frac{e^{-(s-a)t}}{-(s-a)} \right]_0^{\infty} = -\frac{1}{s-a} \left[\frac{1}{e^{-(s-a)t}} \right]_0^{\infty}$

$= \frac{-1}{(s-a)} (0-1) = \frac{1}{s-a}$ **Proved.**

4. $L(\cosh at) = \frac{s}{s^2 - a^2}$

Proof. $L(\cosh at) = L\left[\frac{e^{at} + e^{-at}}{2}\right]$ $\left(\because \cosh at = \frac{e^{at} + e^{-at}}{2}\right)$

$= \frac{1}{2} L(e^{at}) + \frac{1}{2} L(e^{-at}) = \frac{1}{2} \left[\frac{1}{s-a} + \frac{1}{s+a} \right]$ $\left[L(e^{at}) = \frac{1}{s-a} \right]$

$= \frac{1}{2} \left[\frac{s+a+s-a}{s^2 - a^2} \right] = \frac{s}{s^2 - a^2}$ **Proved.**

5. $L(\sinh at) = \frac{a}{s^2 - a^2}$

Proof. $L(\sinh at) = L\left[\frac{1}{2}(e^{at} - e^{-at})\right]$

$= \frac{1}{2} [L(e^{at}) - L(e^{-at})] = \frac{1}{2} \left[\frac{1}{s-a} - \frac{1}{s+a} \right] = \frac{1}{2} \left[\frac{s+a-s+a}{s^2 - a^2} \right]$

$= \frac{a}{s^2 - a^2}$ **Proved.**

6. $L(\sin at) = \frac{a}{s^2 + a^2}$

Proof. $L(\sin at) = L\left[\frac{e^{iat} - e^{-iat}}{2i}\right]$ $\left[\because \sin at = \frac{e^{iat} - e^{-iat}}{2i}\right]$

$= \frac{1}{2i} [L(e^{iat}) - L(e^{-iat})] = \frac{1}{2i} [L(e^{iat}) - L(e^{-iat})]$

$= \frac{1}{2i} \left[\frac{1}{s-ia} - \frac{1}{s+ia} \right] = \frac{1}{2i} \left[\frac{s+ia-s+ia}{s^2 + a^2} \right] = \frac{1}{2i} \frac{2ia}{s^2 + a^2} = \frac{a}{s^2 + a^2}$ **Proved.**

7. $L(\cos at) = \frac{s}{s^2 + a^2}$

Proof. $L(\cos at) = L\left[\frac{e^{iat} + e^{-iat}}{2}\right]$ $\left[\because \cos at = \frac{e^{iat} + e^{-iat}}{2}\right]$

Laplace Transformation

$$\begin{aligned}
 &= \frac{1}{2} [\mathcal{L}(e^{iat} + e^{-iat})] = \frac{1}{2} [\mathcal{L}(e^{iat}) + \mathcal{L}(e^{-iat})] = \frac{1}{2} \left[\frac{1}{s-ia} + \frac{1}{s+ia} \right] = \frac{1}{2} \frac{s+ia+s-ia}{s^2+a^2} \\
 &= \frac{s}{s^2+a^2} \qquad \qquad \qquad \text{Proved.}
 \end{aligned}$$

Example 1. Find the Laplace transform of $f(t)$ defined as

$$f(t) = \begin{cases} \frac{t}{k}, & \text{when } 0 < t < k \\ 1, & \text{when } t > k \end{cases}$$

$$\begin{aligned}
 \text{Solution. } L[f(t)] &= \int_0^k \frac{t}{k} e^{-st} dt + \int_k^\infty 1 \cdot e^{-st} dt = \frac{1}{k} \left[\left(\frac{e^{-st}}{-s} \right)_0^k - \int_0^k \frac{e^{-st}}{-s} dt \right] + \left[\frac{e^{-st}}{-s} \right]_k^\infty \\
 &= \frac{1}{k} \left[\frac{ke^{-ks}}{-s} - \left(\frac{e^{-st}}{-s} \right)_0^k \right] + \frac{e^{-ks}}{s} = \frac{1}{k} \left[\frac{ke^{-ks}}{-s} - \frac{e^{-sk}}{s^2} + \frac{1}{s^2} \right] + \frac{e^{-ks}}{s} \\
 &= -\frac{e^{-sk}}{s} - \frac{1}{k} \frac{e^{-ks}}{s^2} + \frac{1}{k} \frac{1}{s^2} + \frac{e^{-ks}}{s} = \frac{1}{ks^2} [e^{-ks} + 1] \qquad \qquad \qquad \text{Ans.}
 \end{aligned}$$

Example 2. From the first principle, find the Laplace transform of $(1 + \cos 2t)$.

Solution. Laplace transform of $(1 + \cos 2t)$

$$\begin{aligned}
 &= \int_0^\infty e^{-st} (1 + \cos 2t) dt = \int_0^\infty e^{-st} \left(1 + \frac{e^{2it} + e^{-2it}}{2} \right) dt \\
 &= \frac{1}{2} \int_0^\infty [2e^{-st} + e^{(-s+2i)t} + e^{(-s-2i)t}] dt = \frac{1}{2} \left[\frac{2e^{-st}}{-s} + \frac{e^{(-s+2i)t}}{-s+2i} + \frac{e^{(-s-2i)t}}{-s-2i} \right]_0^\infty \\
 &= \frac{1}{2} \left[\left(\frac{0+2}{s} \right) + \frac{1}{-s+2i} (0-1) + \frac{1}{-s-2i} (0-1) \right] \\
 &= \frac{1}{2} \left[\frac{2}{s} + \frac{1}{s} + \frac{1}{s} \right] = \frac{1}{2} \left[\frac{2}{s} + \frac{2s}{s^2+4} \right] \\
 &= \frac{1}{s} + \frac{1}{s^2+4} = \frac{s^2+4+s^2}{s(s^2+4)} \qquad \qquad \qquad \text{Ans.}
 \end{aligned}$$

PROPERTIES OF LAPLACE TRANSFORMS

$$(1) \quad \mathcal{L}[af_1(t) + bf_2(t)] = a \mathcal{L}[f_1(t)] + b \mathcal{L}[f_2(t)]$$

$$\begin{aligned}
 \text{Proof.} \quad \mathcal{L}[af_1(t) + bf_2(t)] &= \int_0^\infty e^{-st} [af_1(t) + bf_2(t)] dt \\
 &= a \int_0^\infty e^{-st} f_1(t) dt + b \int_0^\infty e^{-st} f_2(t) dt \\
 &= a \mathcal{L}[f_1(t)] + b \mathcal{L}[f_2(t)] \qquad \qquad \qquad \text{Proved.}
 \end{aligned}$$

(2) **First Shifting Theorem.** If $\mathcal{L}f(t) = F(s)$, then

$$\mathcal{L}[e^{at} f(t)] = F(s-a)$$

$$\begin{aligned}
 \text{Proof.} \quad \mathcal{L}[e^{at} f(t)] &= \int_0^\infty e^{-st} \cdot e^{at} f(t) dt = \int_0^\infty e^{-(s-a)t} f(t) dt \\
 &= \int_0^\infty e^{-rt} f(t) dt \qquad \text{where } r = s-a \\
 &= F(r) = F(s-a) \qquad \qquad \qquad \text{Proved.}
 \end{aligned}$$

Laplace Transformation

With the help of this property, we can have the following important results :

$$(1) L(e^{at} t^n) = \frac{n!}{(s-a)^{n+1}} \quad \left[L(t^n) = \frac{n!}{s^{n+1}} \right]$$

$$(2) L(e^{at} \cosh bt) = \frac{s-a}{(s-a)^2 - b^2} \quad (3) L(e^{at} \sinh bt) = \frac{b}{(s-a)^2 - b^2}$$

$$(4) L(e^{at} \sin bt) = \frac{b}{(s-a)^2 + b^2} \quad (5) L(e^{at} \cos bt) = \frac{s-a}{(s-a)^2 + b^2}$$

Example 3. Find the Laplace transform of $\cos^2 t$.

Solution. $\cos 2t = 2 \cos^2 t - 1$

$$\begin{aligned} \therefore \cos^2 t &= \frac{1}{2} [\cos 2t + 1] \\ L(\cos^2 t) &= L\left[\frac{1}{2}(\cos 2t + 1)\right] = \frac{1}{2} [L(\cos 2t) + L(1)] \\ &= \frac{1}{2} \left[\frac{s}{s^2 + (2)^2} + \frac{1}{s} \right] = \frac{1}{2} \left[\frac{s}{s^2 + 4} + \frac{1}{s} \right] \end{aligned}$$

Ans.

Example 4. Find the Laplace Transform of $t^{-1/2}$.

Solution. We know that $L(t^n) = \frac{\Gamma(n+1)}{s^{n+1}}$

$$\text{Put } n = -\frac{1}{2}, L(t^{-1/2}) = \frac{\Gamma(-\frac{1}{2} + 1)}{s^{-1/2+1}} = \frac{\Gamma\left(\frac{1}{2}\right)}{\sqrt{s}} = \frac{\sqrt{\pi}}{\sqrt{s}}, \text{ where } \Gamma\left(\frac{1}{2}\right) = \sqrt{\pi}$$

Ans.

Example 5. Find the Laplace Transform of $t \sin at$.

Solution.

$$\begin{aligned} L(t \sin at) &= L\left[t \frac{e^{iat} - e^{-iat}}{2i} \right] = \frac{1}{2i} [L(t e^{iat}) - L(t e^{-iat})] \\ &= \frac{1}{2i} \left[\frac{1}{(s-ia)^2} - \frac{1}{(s+ia)^2} \right] = \frac{1}{2i} \left[\frac{(s+ia)^2 - (s-ia)^2}{(s-ia)^2 (s+ia)^2} \right] \\ &= \frac{1}{2i} \frac{(s^2 + 2ias - a^2) - (s^2 - 2ias - a^2)}{(s^2 + a^2)^2} \\ &= \frac{4ias}{2i (s^2 + a^2)^2} = \frac{2as}{(s^2 + a^2)^2} \end{aligned}$$

Ans.

Example 6. Find the Laplace Transform of $t^2 \cos at$.

Solution.

$$\begin{aligned} L(t^2 \cos at) &= L\left[t^2 \frac{e^{iat} + e^{-iat}}{2} \right] = \frac{1}{2} [L(t^2 e^{iat}) + L(t^2 e^{-iat})] \\ &= \frac{1}{2} \left[\frac{2!}{(s-ia)^3} + \frac{2!}{(s+ia)^3} \right] = \frac{(s+ia)^3 + (s-ia)^3}{(s-ia)^3 (s+ia)^3} \end{aligned}$$

Laplace Transformation

$$= \frac{(s^3 + 3ias^2 - 3a^2s - ia^3) + (s^3 - 3ias^2 - 3a^2s + ia^3)}{(s^2 + a^2)^3}$$

$$= \frac{2s^3 - 6a^2s}{(s^2 + a^2)^3} = \frac{2s(s^2 - 3a^2)}{(s^2 + a^2)^3}$$

Ans.

Exercise 13.1

Find the Laplace transforms of the following:

1. $t + t^2 + t^3$

Ans. $\frac{1}{s^2} + \frac{2}{s^3} + \frac{6}{s^4}$

2. $\sin t \cos t$

Ans. $\frac{1}{s^2 + 4}$

3. $t^{7/2} e^{5t}$

(M.D.U. Dec. 2009)

Ans. $\frac{105\sqrt{\pi}}{16(s-5)^{9/2}}$

4. $\sin^3 2t$

Ans. $\frac{48}{(s^2 + 4)(s^2 + 36)}$

5. $\frac{-t^2}{e} \cos t$

Ans. $\frac{2s + 2}{2s^2 + 4s + 10}$

6. $\sin 2t \cos 3t$

Ans. $\frac{2(s^2 - 5)}{(s^2 + 1)(s^2 + 25)}$

7. $\sin 2t \sin 3t$

Ans. $\frac{12s}{(s^2 + 1)(s^2 + 25)}$

8. $\cos at \sinh at$

Ans. $\frac{1}{2} \left[\frac{s+a}{(s-a)^2 + a^2} - \frac{s+a}{(s+a)^2 + a^2} \right]$

9. $\sinh^3 t$

Ans. $\frac{6}{(s^2 - 1)(s^2 - 9)}$

10. $\cos t \cos 2t$

Ans. $\frac{s(s^2 + 5)}{(s^2 + 1)(s^2 + 9)}$

11. $\cosh at \sin at$

Ans. $\frac{a(s^2 + 2a^2)}{s^4 + 4a^4}$

12. $f(t) = \begin{cases} \cos\left(t - \frac{2\pi}{3}\right), & t > \frac{2\pi}{3} \\ 0, & t < \frac{2\pi}{3} \end{cases}$

Ans. $e^{-\frac{2\pi s}{3}} \cdot \frac{s}{s^2 + 1}$

LAPLACE TRANSFORM OF THE DERIVATIVE OF $f(t)$

$$L[f'(t)] = sL[f(t)] - f(0) \quad \text{where } L[f(t)] = F(s).$$

Proof.

$$L[f'(t)] = \int_0^{\infty} e^{-st} f'(t) dt$$

Integrating by parts, we get

$$L[f'(t)] = [e^{-st} \cdot f(t)]_0^{\infty} - \int_0^{\infty} (-se^{-st}) f(t) dt$$

$$= -f(0) + s \int_0^{\infty} e^{-st} f(t) dt \quad (e^{-st} f(t) = 0, \text{ when } t = \infty)$$

$$= -f(0) + sL[f(t)]$$

 \Rightarrow

$$L[f'(t)] = sL[f(t)] - f(0)$$

Proved.**Note.** Roughly, Laplace transform of **derivative** of $f(t)$ corresponds to multiplication of the Laplace transform of $f(t)$ by s .**LAPLACE TRANSFORM OF DERIVATIVE OF ORDER n .**

$$L[f^n(t)] = s^n L[f(t)] - s^{n-1} f(0) - s^{n-2} f'(0) - s^{n-3} f''(0) - \dots - f^{(n-1)}(0)$$

Proof. We have already proved in Article 13.5 that

Laplace Transformation

$$L[f'(t)] = sL[f(t)] - f(0) \quad \dots(1)$$

Replacing $f(t)$ by $f'(t)$ and $f'(t)$ by $f''(t)$ in (1), we get

$$L[f''(t)] = sL[f'(t)] - f'(0) \quad \dots(2)$$

Putting the value of $L[f'(t)]$ from (1) in (2), we have

$$L[f''(t)] = s[sL[f(t)] - f(0)] - f'(0)$$

$$\Rightarrow L[f''(t)] = s^2L[f(t)] - sf(0) - f'(0)$$

Similarly, $L[f'''(t)] = s^3L[f(t)] - s^2f(0) - sf'(0) - f''(0)$

$$L[f^{iv}(t)] = s^4L[f(t)] - s^3f(0) - s^2f'(0) - sf''(0) - f'''(0)$$

$$L[f^n(t)] = s^nL[f(t)] - s^{n-1}f(0) - s^{n-2}f'(0) - s^{n-3}f''(0) + \dots - f^{n-1}(0)$$

LAPLACE TRANSFORM OF INTEGRAL OF $f(t)$

$$L\left[\int_0^t f(t) dt\right] = \frac{1}{s}F(s), \quad \text{where } L[f(t)] = F(s)$$

Proof. Let $\phi(t) = \int_0^t f(t) dt$ and $\phi(0) = 0$ then $\phi'(t) = f(t)$

We know the formula of Laplace transforms of $\phi'(t)$ i.e.

$$L[\phi'(t)] = sL[\phi(t)] - \phi(0)$$

$$\Rightarrow L[\phi'(t)] = sL[\phi(t)] \quad [\phi(0) = 0]$$

$$\Rightarrow L[\phi(t)] = \frac{1}{s}L[\phi'(t)]$$

Putting the values of $\phi(t)$ and $\phi'(t)$, we get

$$L\left[\int_0^t f(t) dt\right] = \frac{1}{s}L[f(t)] \quad \text{or} \quad L\left[\int_0^t f(t) dt\right] = \frac{1}{s}F(s)$$

Proved.

Note: (1) Laplace Transform of Integral of $f(t)$ corresponds to the division of the Laplace

$$(2) \quad \int_0^t f(t) dt = L^{-1}\left[\frac{1}{s}F(s)\right]$$

LAPLACE TRANSFORM OF $t \cdot f(t)$ (Multiplication by t)

If $L[f(t)] = F(s)$, then

$$L[t^n f(t)] = (-1)^n \frac{d^n}{ds^n} [F(s)].$$

Proof. $L[f(t)] = F(s) = \int_0^\infty e^{-st} f(t) dt \quad \dots (1)$

Differentiating (1) w.r.t. "s" we get

$$\begin{aligned} \therefore \frac{d}{ds} [F(s)] &= \frac{d}{ds} \left[\int_0^\infty e^{-st} f(t) dt \right] = \int_0^\infty \frac{\partial}{\partial s} (e^{-st}) f(t) dt \\ &= \int_0^\infty (-te^{-st}) f(t) dt = \int_0^\infty e^{-st} [-t \cdot f(t)] dt \\ &= L[-t f(t)] \quad \text{or} \quad L[tf(t)] = (-1)^1 \frac{d}{ds} [F(s)] \end{aligned}$$

Laplace Transformation

$$\text{Similarly } \mathcal{L}[t^2 f(t)] = \frac{d^2}{ds^2} [F(s)]$$

$$\mathcal{L}[t^3 f(t)] = (-1)^3 \frac{d^3}{ds^3} [F(s)]$$

$$\mathcal{L}[t^n f(t)] = (-1)^n \frac{d^n}{ds^n} [F(s)] \quad \dots$$

Proved.

Example 7. Find the Laplace transform of $t \sinh at$.

$$\begin{aligned} \text{Solution. } \mathcal{L}(\sinh at) &= \frac{a}{s^2 - a^2} \\ \therefore \mathcal{L}[t \sinh at] &= \frac{d}{ds} \left(\frac{a}{s^2 - a^2} \right) \\ &= \frac{-2as}{(s^2 - a^2)^2} \end{aligned}$$

$$\Rightarrow \mathcal{L}[t \sinh at] = \frac{-2as}{(s^2 - a^2)^2}$$

Ans.

Example 8. Find the Laplace transform of $t^2 \cos at$

$$\begin{aligned} \text{Solution. } \mathcal{L}(\cos at) &= \frac{s}{s^2 + a^2} \\ \mathcal{L}(t^2 \cos at) &= (-1)^2 \frac{d^2}{ds^2} \left[\frac{s}{s^2 + a^2} \right] = \frac{d}{ds} \left(\frac{(s^2 + a^2) \cdot 1 - s(2s)}{(s^2 + a^2)^2} \right) = \frac{d}{ds} \left(\frac{a^2 - s^2}{(s^2 + a^2)^2} \right) \\ &= \frac{(s^2 + a^2)^2 (-2s) - (a^2 - s^2) \cdot 2(s^2 + a^2)(2s)}{(s^2 + a^2)^4} = \frac{-2s^3 - 2a^2s - 4a^2s + 4s^3}{(s^2 + a^2)^3} \\ &= \frac{2s(s^2 - 3a^2)}{(s^2 + a^2)^3} \end{aligned}$$

Ans.

Example 9. Obtain the Laplace transform of $t^2 e^t \sin 4t$

$$\begin{aligned} \text{Solution. } \mathcal{L}(\sin 4t) &= \frac{4}{s^2 + 16}, \mathcal{L}(e^t \sin 4t) = \frac{4}{(s-1)^2 + 16} \\ \mathcal{L}(t e^t \sin 4t) &= -\frac{d}{ds} \left(\frac{4}{(s-1)^2 + 16} \right) = \frac{4(2s-2)}{(s^2 - 2s + 17)^2} \\ \mathcal{L}(t^2 e^t \sin 4t) &= -4 \frac{d}{ds} \left(\frac{s^2 - 2s + 17}{(s^2 - 2s + 17)^2} \right) \\ &= -4 \frac{(s^2 - 2s + 17)^2 \cdot 2 - (2s - 2) \cdot 2(s^2 - 2s + 17)(2s - 2)}{(s^2 - 2s + 17)^4} \\ &= \frac{-4(2s^2 - 4s + 34 - 8s^2 + 16s - 8)}{(s^2 - 2s + 17)^3} \\ &= \frac{-4(-6s^2 + 12s + 26)}{(s^2 - 2s + 17)^3} = \frac{8(3s^2 - 6s - 13)}{(s^2 - 2s + 17)^3} \end{aligned}$$

Ans.

Exercise 13.2

Find the Laplace transforms of the following :

1. $t \sin 2t$ (Madras 2006) **Ans.** $\frac{4s}{(s^2+4)^2}$ 2. $t \sin at$ **Ans.** $\frac{2as}{(s^2+a^2)^2}$
3. $t \cosh at$ **Ans.** $\frac{s^2+a^2}{(s^2-a^2)^2}$ 4. $t \cos t$ **Ans.** $\frac{s^2-1}{(s^2+1)^2}$
 $\frac{s^2+1}{s^2+1}$ $\frac{2(3s^2-1)}{s^2-36}$
5. $t \cosh t$ **Ans.** $\frac{(s^2-1)^2}{6}$ 6. $t^2 \sin t$ **Ans.** $\frac{(s^2+1)^3}{s^2-36}$
7. $t^3 e^{-3t}$ **Ans.** $\frac{6}{(s+3)^4}$ 8. $t \sin^2 3t$ **Ans.** $2 \left[\frac{1}{s^2} - \frac{1}{(s^2+36)^2} \right]$
9. $t e^{at} \sin at$ **Ans.** $\frac{2a(s-a)}{(s^2-2as+2a^2)^2}$
10. $\int_0^t e^{-2t} t \sin^3 t dt$ **Ans.** $\frac{3(s+2)}{2s} \left[\frac{1}{(s+2)^2+9} - \frac{1}{(s+2)^2+1} \right]$
11. $t e^{-t} \cosh t$ **Ans.** $\frac{s^2+2s+2}{(s^2+2s)^2}$
12. $t^2 e^{-2t} \cos t$ **Ans.** $\frac{2(s^3+6s^2+9s+2)}{(s^2+4s+5)^3}$
13. (a) Laplace transform of $t^n e^{-at}$ is
 (i) $\frac{\sqrt{n}}{(s+a)^n}$ (ii) $\frac{(n+1)!}{(s+a)^{n+1}}$ (iii) $\frac{n!}{(s+a)^n}$ (iv) $\frac{\sqrt{n+1}}{(s+a)^{n+1}}$ **Ans. (iv)**
- (b) Laplace transform of $f(t) = t e^{at} \cdot \sin(at), t > 0$
 (i) $\frac{2a(s-a)}{[(s-a)^2+a^2]^2}$ (ii) $\frac{a(s-a)}{(s-a)^2+a^2}$ (iii) $\frac{s-a}{(s-a)^2+a^2}$ (iv) $\frac{(s-a)^2}{(s-a)^2+a^2}$ **Ans. (i)**
- (c) If $f(x) = x^4 P(x)$, where $P(x)$ has derivatives of all orders, then $L \left[\frac{d^4 f(x)}{dx^4} \right]$ is given by
 (i) $s^3 L[f(x)]$ (ii) $s^4 Lf(x)$
 (iii) $s^4 L[f^3(x)]$ (iv) none of these. **Ans. (ii)**
- (d) The Laplace transform of $te^{-t} \cosh 2t$ is
 (i) $\frac{s^2+2s+5}{s^2+2s-3}$ (ii) $\frac{s^2-2s+5}{s^2+2s-3}$
 (iii) $\frac{4s+4}{(s^2+2s-3)^2}$ (iv) $\frac{4s-4}{(s^2+2s-3)^2}$ **Ans. (i)**

Laplace Transformation

LAPLACE TRANSFORM OF $\frac{1}{t} f(t)$ (Division by t)

If $L[f(t)] = F(s)$, then $L\left[\frac{1}{t} f(t)\right] = \int_s^\infty F(s) ds$

Proof. $L[f(t)] = F(s) \Rightarrow F(s) = \int_0^\infty e^{-st} f(t) dt$... (1)

Integrating (1) w.r.t. 's', we have

$$\begin{aligned} \int_s^\infty F(s) ds &= \int_s^\infty \left[\int_0^\infty e^{-st} f(t) dt \right] ds \\ &= \int_0^\infty \left[\int_s^\infty e^{-st} f(t) ds \right] dt = \int_0^\infty \left[\frac{e^{-st}}{-t} \right]_s^\infty dt \\ &= \int_0^\infty \frac{-f(t)}{t} \left[e^{-st} \right]_s^\infty dt = \int_0^\infty \frac{-f(t)}{t} \left[0 - e^{-st} \right] dt \\ &= \int_0^\infty e^{-st} \left\{ \frac{1}{t} f(t) \right\} dt = L\left[\frac{1}{t} f(t)\right] \end{aligned}$$

$\Rightarrow L\left[\frac{1}{t} f(t)\right] = \int_s^\infty F(s) ds.$

Proved.

Cor. $L^{-1} \int_s^\infty F(s) ds = \frac{1}{t} f(t)$

Example 10. Find the Laplace transform of $\frac{\sin 2t}{t}$.

Solution. $L(\sin 2t) = \frac{2}{s^2 + 4}$

$$\begin{aligned} L\left(\frac{\sin 2t}{t}\right) &= \int_s^\infty \frac{2}{s^2 + 4} ds = 2 \cdot \frac{1}{2} \left[\tan^{-1} \frac{s}{2} \right]_s^\infty \\ &= \left[\tan^{-1} \infty - \tan^{-1} \frac{s}{2} \right] = \frac{\pi}{2} - \tan^{-1} \frac{s}{2} \\ &= \cot^{-1} \frac{s}{2} \end{aligned}$$

Ans.

Example 11. Find the Laplace transform of $f(t) = \int_0^t \frac{\sin t}{t} dt$.

Solution. $L \sin t = \frac{1}{s^2 + 1}$

$$\begin{aligned} L \frac{\sin t}{t} &= \int_s^\infty \frac{1}{s^2 + 1} ds = \left[\tan^{-1} s \right]_s^\infty = \frac{\pi}{2} - \tan^{-1} s = \cot^{-1} s \\ L \int_0^t \frac{\sin t}{t} dt &= \frac{1}{s} \cot^{-1} s \end{aligned}$$

Ans.

Example 12. Find the Laplace transform of $\frac{1 - \cos t}{t^2}$.

Laplace Transformation

Solution. $L(1 - \cos t) = L(1) - L(\cos t) = \frac{1}{s} - \frac{s}{s^2 + 1}$

$$\begin{aligned} L\left(\frac{1 - \cos t}{t}\right) &= \int_0^\infty \left(\frac{1}{s} - \frac{s}{s^2 + 1}\right) ds = \left[\log s - \frac{1}{2} \log(s^2 + 1) \right]_0^\infty \\ &= \frac{1}{2} \left[\log s^2 - \log(s^2 + 1) \right]_0^\infty = \frac{1}{2} \left[\log \frac{s^2}{s^2 + 1} \right]_0^\infty \\ &= \frac{1}{2} \left[\log \frac{s^2}{s^2 \left(1 + \frac{1}{s^2}\right)} \right]_0^\infty = \frac{1}{2} \left[0 - \log \frac{1}{s^2 + 1} \right]_0^\infty = -\frac{1}{2} \log \frac{s^2}{s^2 + 1} \end{aligned}$$

Again, $L\left[\frac{1 - \cos t}{t}\right] = -\frac{1}{2} \int_0^\infty \log \frac{s^2}{s^2 + 1} ds = -\frac{1}{2} \int_0^\infty \left(\log \frac{s^2}{s^2 + 1} \cdot 1 \right) ds$

Integrating by parts, we have

$$\begin{aligned} &= -\frac{1}{2} \left[\log \frac{s^2}{s^2 + 1} \cdot s - \int_0^\infty \frac{s^2 + 1}{s^2} \cdot \frac{(s^2 + 1)2s - s^2(2s)}{(s^2 + 1)^2} \cdot s ds \right]_0^\infty \\ &= -\frac{1}{2} \left[s \log \frac{s^2}{s^2 + 1} - 2 \int_0^\infty \frac{1}{s^2 + 1} ds \right]_0^\infty = -\frac{1}{2} \left[s \log \frac{s^2}{s^2 + 1} - 2 \tan^{-1} s \right]_0^\infty \\ &= -\frac{1}{2} \left[0 - 2 \left(\frac{\pi}{2} \right) - s \log \frac{s^2}{s^2 + 1} + 2 \tan^{-1} s \right]_0^\infty = -\frac{1}{2} \left[-\pi - s \log \frac{s^2}{s^2 + 1} + 2 \tan^{-1} s \right]_0^\infty \\ &= \frac{\pi}{2} + \frac{s}{2} \log \frac{s^2}{s^2 + 1} - \tan^{-1} s \\ &= \left(\frac{\pi}{2} - \tan^{-1} s \right) + \frac{s}{2} \log \frac{s^2}{s^2 + 1} = \cot^{-1} s + \frac{s}{2} \log \frac{s^2}{s^2 + 1}. \end{aligned}$$

Ans.

Example 13. Evaluate $L\left[e^{-4t} \frac{\sin 3t}{t}\right]$.

Solution. $L \sin 3t = \frac{3}{s^2 + 3^2} \Rightarrow L \frac{\sin 3t}{t} = \int_s^\infty \frac{3}{s^2 + 9} ds = \left[\frac{3}{3} \tan^{-1} \frac{s}{3} \right]_s^\infty$

$$\begin{aligned} &= \frac{\pi}{2} - \tan^{-1} \frac{s}{3} = \cot^{-1} \frac{s}{3} \\ L\left[e^{-4t} \frac{\sin 3t}{t}\right] &= \cot^{-1} \frac{s}{3} = \tan^{-1} \frac{3}{s + 4} \end{aligned}$$

Ans.

Exercise 13.3

Find Laplace transform of the following:

- $\frac{1}{t}(1 - e^t)$ **Ans.** $\log \frac{s-1}{s}$
- $\frac{1}{t}(e^{-at} - e^{-bt})$ **Ans.** $\log \frac{s+b}{s+a}$
- $\frac{1}{t}(1 - \cos at)$ **Ans.** $-\frac{1}{2} \log \frac{s^2 + a^2}{s^2 + 4a^2}$
- $\frac{1}{t} \sin^2 t$ **Ans.** $\frac{1}{4} \log \frac{s^2}{s^2 + 4}$
- $\frac{1}{t} \sinh t$ **Ans.** $-\frac{1}{2} \log \frac{s-1}{s+1}$

Laplace Transformation

$$6. \int_0^1 (e^{-t} \sin t) dt \quad \text{Ans. } \cot^{-1}(s+1)$$

$$7. \int_0^{\infty} (1 - \cos t) dt \quad \text{Ans. } \frac{1}{2} [\log(s^2 + 1) - \log s^2]$$

$$8. \int_0^{\infty} \frac{e^{-2t} \sin t}{t} dt \quad \text{Ans. } \frac{1}{s} \cot^{-1} \frac{1}{s+2}$$

$$9. \int_0^{\infty} \frac{e^{-t} - e^{-3t}}{t} dt \quad \text{Ans. } \log 3$$

$$10. \int_0^{\infty} t (\cos at - \cos bt) dt \quad \text{Ans. } -\frac{1}{2} \log \frac{s^2 + a^2}{s^2 + b^2}$$

UNIT STEP FUNCTION

With the help of unit step functions, we can find the inverse transform of functions, which cannot be determined with previous methods.

The unit step functions $u(t-a)$ is defined as follows:

$$u(t-a) = \begin{cases} 0 & \text{when } t < a \\ 1 & \text{when } t \geq a \end{cases} \quad \text{where } a \geq 0.$$

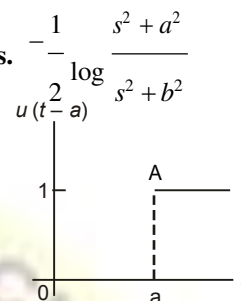

Example 14. Express the following function in terms of units step functions and find its Laplace transform:

$$f(t) = \begin{cases} 8, & t < 2 \\ 6, & t > 2 \end{cases}$$

Solution.

$$\begin{aligned} f(t) &= \begin{cases} 8+0, & t < 2 \\ 8-2, & t > 2 \end{cases} \\ &= 8 + \begin{cases} 0, & t < 2 \\ -2, & t > 2 \end{cases} = 8 + (-2) \begin{cases} 0, & t < 2 \\ 1, & t > 2 \end{cases} \\ &= 8 - 2u(t-2) \end{aligned}$$

$$L f(t) = 8 L(1) - 2 L u(t-2) = \frac{8}{s} - 2 \frac{e^{-2s}}{s}$$

Ans.

Example 15. Draw the graph of $u(t-a) - u(t-b)$

Solution. As in Art 13.10 the graph of $u(t-a)$ is a straight line from A to ∞ . Similarly, the graph of $u(t-b)$ a straight line from B to ∞ .

Hence, the graph of $u[t-a] - u[t-b]$ is AB.

Example 16. Express the following function in terms of unit step function and find its Laplace transform :

$$f(t) = \begin{cases} E, & a < t < b \\ 0, & t > b \end{cases}$$

Solution.

$$f(t) = E \begin{cases} 1, & a < t < b \\ 0, & t > b \end{cases} = E [u(t-a) - u(t-b)]$$

$$L f(t) = E \left[\frac{e^{-as}}{s} - \frac{e^{-bs}}{s} \right]$$

Ans.

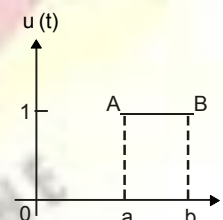

Laplace Transformation

Example 17. Express the following function in terms of unit step function :

$$f(t) = \begin{cases} t-1, & 1 < t < 2 \\ 3-t, & 2 < t < 3 \end{cases}$$

and find its Laplace transform.

Solution.

$$\begin{aligned} f(t) &= \begin{cases} t-1, & 1 < t < 2 \\ 3-t, & 2 < t < 3 \end{cases} \\ &= (t-1)[u(t-1) - u(t-2)] + (3-t)[u(t-2) - u(t-3)] \\ &= (t-1)u(t-1) - (t-1)u(t-2) + (3-t)u(t-2) - (t-3)u(t-3) \\ &= (t-1)u(t-1) - 2(t-2)u(t-2) + (t-3)u(t-3) \end{aligned}$$

$$Lf(t) = \frac{e^{-s}}{s} - \frac{2e^{-2s}}{s} + \frac{e^{-3s}}{s}$$

Ans.

Laplace Transform of unit function

$$L[u(t-a)] = \frac{e^{-as}}{s}$$

Proof.

$$\begin{aligned} L[u(t-a)] &= \int_0^{\infty} e^{-st} u(t-a) dt \\ &= \int_0^a e^{-st} \cdot 0 dt + \int_a^{\infty} e^{-st} \cdot 1 dt = 0 + \left[\frac{e^{-st}}{-s} \right]_a^{\infty} \end{aligned}$$

$$\therefore L[u(t-a)] = \frac{e^{-as}}{s}$$

Proved.

SECOND SHIFTING THEOREM

If $L[f(t)] = F(s)$, then $L[f(t-a) \cdot u(t-a)] = e^{-as} F(s)$.

Proof.

$$\begin{aligned} L[f(t-a) \cdot u(t-a)] &= \int_0^{\infty} e^{-st} [f(t-a) \cdot u(t-a)] dt \\ &= \int_0^a e^{-st} f(t-a) \cdot 0 dt + \int_a^{\infty} e^{-st} f(t-a) \cdot 1 dt \\ &= \int_0^{\infty} e^{-st} f(t-a) dt \\ &= \int_0^{\infty} e^{-s(u+a)} f(u) du \quad \text{where } u = t-a \\ &= e^{-sa} \int_0^{\infty} e^{-su} \cdot f(u) du = e^{-sa} F(s) \end{aligned}$$

Proved.

THEOREM

$$L[f(t) \cdot u(t-a)] = e^{-as} L[f(t+a)]$$

Proof.

$$\begin{aligned} L[f(t) \cdot u(t-a)] &= \int_0^{\infty} e^{-st} [f(t) \cdot u(t-a)] dt \\ &= \int_0^a e^{-st} [f(t) \cdot u(t-a)] dt + \int_a^{\infty} e^{-st} [f(t) \cdot u(t-a)] dt \end{aligned}$$

Laplace Transformation

$$\begin{aligned}
 &= 0 + \int_a^\infty e^{-st} \cdot f(t) \cdot (1) dt \\
 &= \int_0^\infty e^{-s(y+a)} \cdot f(y+a) dy = e^{-as} \int_0^\infty e^{-sy} \cdot f(y+a) dy \quad (t-a=y) \\
 &= e^{-as} \int_0^\infty e^{-sy} \cdot f(y+a) dy = e^{-as} Lf(y+a)
 \end{aligned}$$

Proved.

Example 18. Find the Laplace Transform of $t^2 u(t-3)$.

Solution. $t^2 \cdot u(t-3) = [(t-3)^2 + 6(t-3) + 9]u(t-3)$

$$\begin{aligned}
 &= (t-3)^2 \cdot u(t-3) + 6(t-3) \cdot u(t-3) + 9u(t-3) \\
 L t^2 \cdot u(t-3) &= L (t-3)^2 \cdot u(t-3) + 6L(t-3) \cdot u(t-3) + 9L u(t-3) \\
 &= e^{-3s} \left[\frac{2}{s^3} + \frac{6}{s^2} + \frac{9}{s} \right]
 \end{aligned}$$

Ans.

Aliter $L t^2 u(t-3) = e^{-3s} L (t+3)^2 = e^{-3s} L [t^2 + 6t + 9]$

$$= e^{-3s} \left[\frac{2}{s^3} + \frac{6}{s^2} + \frac{9}{s} \right]$$

Ans.

Example 19. Find the Laplace transform of $e^{-2t} u_\pi(t)$.

where $u_\pi(t) = \begin{cases} 0: & t < \pi \\ 1: & t > \pi \end{cases}$

Solution. $u(t) = \begin{cases} 0: & t < \pi \\ 1: & t > \pi \end{cases}$

$$= u(t - \pi)$$

$$\begin{aligned}
 L e^{-2t} u_\pi(t) &= L e^{-2t} u(t - \pi) \quad f(t) = e^{-2t} \\
 &= e^{-\pi s} L f(t + \pi) \quad f(t + \pi) = e^{-2(t+\pi)} \\
 &= e^{-\pi s} L e^{-2(t+\pi)} = e^{-\pi s} e^{-2\pi} L e^{-2t} \\
 &= e^{-(\pi s + 2\pi)} \frac{1}{s+2} \\
 &= \frac{e^{-\pi(s+2)}}{s+2}
 \end{aligned}$$

Ans.

Example 20. Represent $f(t) = \sin 2t$, $2\pi < t < 4\pi$ and $f(t) = 0$ otherwise, in terms of unit step function and then find its Laplace transform.

Solution. $f(t) = \begin{cases} \sin 2t, & 2\pi < t < 4\pi \\ 0, & \text{otherwise} \end{cases}$

$$\begin{aligned}
 f(t) &= \sin 2t [u(t-2\pi) - u(t-4\pi)] \\
 Lf(t) &= L [\sin 2t \cdot u(t-2\pi)] - L [\sin 2t \cdot u(t-4\pi)] \\
 &= e^{-2\pi s} L [\sin 2(t+2\pi)] - e^{-4\pi s} L [\sin 2(t+4\pi)] \\
 &= e^{-2\pi s} L [\sin 2t] - e^{-4\pi s} L [\sin 2t] \\
 &= e^{-2\pi s} \frac{2}{s^2+4} - e^{-4\pi s} \frac{2}{s^2+4} \\
 &= \frac{(e^{-2\pi s} - e^{-4\pi s})}{s^2+4}
 \end{aligned}$$

Ans.

Exercise 13.4

Find the Laplace transform of the following:

$$1. f(t) = \begin{cases} t-1, & 1 < t < 2 \\ 0, & \text{otherwise} \end{cases}$$

$$\text{Ans. } \frac{e^{-s} - e^{-2s}}{s^2} - \frac{e^{-2s}}{s}$$

$$2. \frac{e^t u(t-1)}{1-e^{2t}} + tu(t) + \cosh t \cdot \cos t$$

$$\text{Ans. } \frac{e^{-(s-1)}}{s-1-2} + \frac{1}{s^2} + \frac{s^3}{s^2+4}$$

$$3. t u(t-2)$$

$$\text{Ans. } \frac{\log \frac{1}{e^{-2s}}}{s} + \frac{1}{2s^2} + \frac{s^4+4}{s^2+4}$$

$$4. \sin t u(t-4)$$

$$\text{Ans. } \frac{1}{s^3} (4s + 4s + 2)$$

$$5. f(t) = K(t-2)[u(t-2) - u(t-3)]$$

$$\text{Ans. } \frac{e^{-4s}}{s+1} [\cos 4 + s \sin 4]$$

$$6. f(t) = K \frac{\sin \pi t}{T} [u(t-2T) - u(t-3T)]$$

$$\text{Ans. } \frac{K}{s^2} [e^{-2s} - (s+1)e^{-3s}]$$

Express the following in terms of unit step functions and obtain Laplace transforms.

$$8. f(t) = \begin{cases} t, & 0 < t < 2 \\ 0, & 2 < t \\ \sin t, & 0 < t < \pi \end{cases}$$

$$\text{Ans. } u(t) - u(t-2), \frac{1 - (2s+1)e^{-2s}}{s^2}$$

$$9. f(t) = \begin{cases} t, & t > \pi \\ 4, & 0 < t < 1 \\ -2, & 0 < t < 3 \\ 5, & t > 3 \end{cases}$$

$$\text{Ans. } \frac{1 + e^{-\pi s}}{s^2 + 1} + \frac{e^{-\pi s} (\pi s + 1)}{s^2}$$

$$10. f(t) = \begin{cases} 4, & 0 < t < 1 \\ -2, & 0 < t < 3 \\ 5, & t > 3 \end{cases}$$

$$\text{Ans. } \frac{4 - 6e^{-s} + 7e^{-3s}}{s}$$

11. The Laplace transform of $t u_2(t)$ is

$$(i) \left(\frac{1}{s^2} + \frac{2}{s} \right) e^{-2s} \quad (ii) \frac{1}{s^2} e^{-2s}$$

$$(iii) \left(\frac{1}{s^2} - \frac{2}{s} \right) e^{-2s}$$

$$(iv) \frac{e^{-2s}}{s^2}$$

Ans. (i)

(1) IMPULSE FUNCTION

When a large force acts for a short time, then the product of the force and the time is called impulse in applied mechanics. The unit impulse function is the limiting function.

$$\delta(t-1) = \frac{1}{\varepsilon}, a < t < a + \varepsilon$$

$$= 0, \text{ otherwise}$$

The value of the function (height of the strip in the figure) becomes infinite as $\varepsilon \rightarrow 0$ and the area of the rectangle is unity.

(2) The Unit Impulse function is defined as follows:

$$\delta(t-a) = \begin{cases} \infty & \text{for } t = a \\ 0 & \text{for } t \neq a. \end{cases}$$

$$\text{and } \int_0^{\infty} \delta(t-a) dt = 1$$

[Area of strip = 1]

(3) Laplace Transform of unit Impulse function

$$\int_0^{\infty} f(t) \delta(t-a) dt = \int_a^{a+\varepsilon} f(t) \cdot \frac{1}{\varepsilon} dt$$

$$\left\{ \begin{array}{l} \text{Mean value Thorem} \\ \int_a^b f(t) dt = (b-a) f(\eta) \end{array} \right.$$

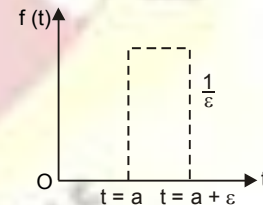

Laplace Transformation

$$= (a + \varepsilon - a) f(\eta), \frac{1}{\varepsilon} \quad \text{where } a < \eta < a + \varepsilon$$

$$= f(\eta)$$

Property I: $\int_0^{\infty} f(t) \delta(t-a) dt = f(a)$ as $\varepsilon \rightarrow 0$

Note. If $f(t) = e^{-st}$ and $L[\delta(t-a)] = e^{-as}$

Example 21. Evaluate $\int_{-\infty}^{\infty} e^{-5t} \delta(t-2) dt$.

Solution. $\int_{-\infty}^{\infty} e^{-5t} \delta(t-2) dt = e^{-5 \times 2} = e^{-10}$ **Ans.**

Property II: $\int_{-\infty}^{\infty} f(t) \delta'(t-a) dt = -f'(a)$

Proof. $\int_{-\infty}^{\infty} f(t) \delta'(t-a) dt = [f(t) \delta(t-a)]_{-\infty}^{\infty} - \int_{-\infty}^{\infty} f'(t) \delta(t-a) dt$
 $= 0 - 0 - f'(a) = -f'(a)$

Example 22. Find the Laplace transform of $t^3 \delta(t-4)$.

Solution. $L[t^3 \delta(t-4)] = \int_0^{\infty} e^{-st} t^3 \delta(t-4) dt$
 $= 4^3 e^{-4s}$ **Ans.**

Exercise 13.5

Evaluate the following :

- $\int_0^{\infty} e^{-3t} \delta(t-4) dt$ **Ans.** e^{-12}
- $\int_{-\infty}^{\infty} \sin 2t \delta\left(t - \frac{\pi}{4}\right) dt$ **Ans.** 1.
- $\int_{-\infty}^{\infty} e^{-3t} \delta'(t-2) dt$ **Ans.** $3e^{-6}$
- $\frac{\delta(t-4)}{t}$ **Ans.** $\frac{e^{-4s}}{4}$
- Laplace transforms of $\cos t \log t \delta(t-\pi)$ **Ans.** $-e^{-\pi s} \log \pi$
- $e^{-4t} \delta(t-3)$ **Ans.** $e^{-3(s+4)}$

PERIODIC FUNCTIONS

Let $f(t)$ be a periodic function with Period T , then

$$L[f(t)] = \frac{\int_0^T e^{-st} f(t) dt}{1 - e^{-sT}}$$

Proof. $L[f(t)] = \int_0^{\infty} e^{-st} f(t) dt$

$$= \int_0^T e^{-st} f(t) dt + \int_T^{2T} e^{-st} f(t) dt + \int_{2T}^{3T} e^{-st} f(t) dt + \dots$$

Substituting $t = u + T$ in second integral and $t = u + 2T$ in third integral, and so on.

$$L[f(t)] = \int_0^T e^{-st} f(t) dt + \int_0^T e^{-s(u+T)} f(u+T) du + \int_0^T e^{-s(u+2T)} f(u+2T) du + \dots$$

$$= \int_0^T e^{-st} f(t) dt + e^{-sT} \int_0^T e^{-su} f(u) du + e^{-2sT} \int_0^T e^{-su} f(u) du + \dots$$

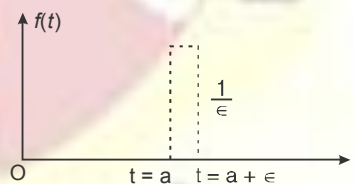

Laplace Transformation

$$\begin{aligned}
 f(u) &= f(u+T) = f(u+2T) = f(u+3T) = \dots \\
 &= \int_0^T e^{-st} f(t) dt + e^{-sT} \int_0^T e^{-st} f(t) dt + e^{-2sT} \int_0^T e^{-st} f(t) dt + \dots \\
 &= \left[1 + e^{-sT} + e^{-2sT} + e^{-3sT} + \dots \right] \int_0^T e^{-st} f(t) dt \quad \left[1 + a + a^2 + a^3 + \dots = \frac{1}{1-a} \right] \\
 &= \frac{1}{1 - e^{-sT}} \int_0^T e^{-st} f(t) dt.
 \end{aligned}$$

Proved.**Example 23.** Find the Laplace transform of the waveform

$$f(t) = \left(\frac{2t}{3} \right), 0 \leq t \leq 3.$$

Solution.

$$L[f(t)] = \frac{1}{1 - e^{-sT}} \int_0^T e^{-st} f(t) dt$$

$$\begin{aligned}
 L\left[\frac{2t}{3}\right] &= \frac{1}{1 - e^{-3s}} \int_0^3 e^{-st} \left(\frac{2t}{3}\right) dt = \frac{1}{1 - e^{-3s}} \left[\frac{2}{3} \left(-\frac{1}{s} \right) \left(\frac{t^2}{2} \right) \right]_0^3 \\
 &= \frac{2}{3} \frac{1}{1 - e^{-3s}} \left[\frac{3e^{-3s}}{s} - \frac{e^{-3s}}{s} + \frac{1}{s} \right] = \frac{2}{3} \frac{1}{1 - e^{-3s}} \left[\frac{3e^{-3s} + 1 - e^{-3s}}{s} \right] \\
 &= \frac{2e^{-3s}}{-s(1 - e^{-3s})} + \frac{2}{3s^2}
 \end{aligned}$$

Ans.**Example 24.** Find the Laplace transform of the function (Half wave rectifier)

$$f(t) = \begin{cases} \sin \omega t & \text{for } 0 < t < \frac{\pi}{\omega} \\ 0 & \text{for } \frac{\pi}{\omega} < t < \frac{2\pi}{\omega} \end{cases}$$

(U.P. II Semester, 2010, Summer 2002)

Solution.

$$L[f(t)] = \frac{1}{1 - e^{-sT}} \int_0^T e^{-st} f(t) dt$$

$$\left[f(t) \text{ is a periodic function} \right]$$

$$= \frac{1}{1 - e^{-\frac{2\pi s}{\omega}}} \int_0^{\frac{2\pi}{\omega}} e^{-st} f(t) dt$$

$$= \frac{1}{1 - e^{-\frac{2\pi s}{\omega}}} \left[\int_0^{\frac{\pi}{\omega}} e^{-st} \sin \omega t dt + \int_{\frac{\pi}{\omega}}^{\frac{2\pi}{\omega}} e^{-st} \times 0 \times dt \right]$$

$$= \frac{1}{1 - e^{-\frac{2\pi s}{\omega}}} \int_0^{\frac{\pi}{\omega}} e^{-st} \sin \omega t dt$$

$$= \frac{1}{1 - e^{-\frac{2\pi s}{\omega}}} \int_0^{\frac{\pi}{\omega}} e^{-st} \sin \omega t dt$$

$$\left[\int e^{ax} \sin bx dx = e^{ax} \frac{a \sin bx - b \cos bx}{a^2 + b^2} \right]$$

$$L[f(t)] = \frac{1}{1 - e^{-\frac{2\pi s}{\omega}}} \left[\frac{e^{-st} (-s \sin \omega t - \omega \cos \omega t)}{s^2 + \omega^2} \right]_0^{\frac{\pi}{\omega}}$$

$$= \frac{1}{1 - e^{-\frac{2\pi s}{\omega}}} \left[\frac{\omega e^{-\frac{\pi s}{\omega}}}{s^2 + \omega^2} \right] = \frac{\omega}{(s^2 + \omega^2)} \left[\frac{1 + e^{-\frac{\pi s}{\omega}}}{1 - e^{-\frac{2\pi s}{\omega}}} \right]$$

Laplace Transformation

$$\begin{aligned}
 &= \frac{\omega \left[1 + e^{-\frac{\pi}{\omega} s} \right]}{(s^2 + \omega^2) \left(1 - e^{-\frac{\pi}{\omega} s} \right) \left(1 + e^{-\frac{\pi}{\omega} s} \right)} \\
 &= \frac{\omega}{(s^2 + \omega^2) \left[1 - e^{-\frac{\pi s}{\omega}} \right]}
 \end{aligned}$$

Ans.

Example 25. Find the Laplace Transform of the Periodic function (saw tooth wave)

$$f(t) = \frac{kt}{T} \text{ for } 0 < t < T, \quad f(t+T) = f(t)$$

Solution. $L[f(t)] = \frac{1}{1 - e^{-sT}} \int_0^T e^{-st} f(t) dt = \frac{1}{1 - e^{-sT}} \int_0^T e^{-st} \frac{kt}{T} dt$

$$= \frac{1}{1 - e^{-sT}} \frac{k}{T} \int_0^T e^{-st} \cdot t dt = \frac{k}{T(1 - e^{-sT})} \left[t \frac{e^{-st}}{-s} - \int 1 \cdot \frac{e^{-st}}{-s} dt \right]_0^T$$

Integrating by parts

$$\begin{aligned}
 &= \frac{k}{T(1 - e^{-sT})} \left[\frac{te^{-st}}{-s} - \frac{e^{-st}}{s^2} \right]_0^T = \frac{k}{T(1 - e^{-sT})} \left[\frac{Te^{-sT}}{-s} - \frac{e^{-sT}}{s^2} + \frac{1}{s^2} \right] \\
 &= \frac{k}{T(1 - e^{-sT})} \left[\frac{1}{-s} + \frac{1}{s^2} (1 - e^{-sT}) \right] + \frac{1}{Ts^2}
 \end{aligned}$$

Ans.

Example 26. Obtain Laplace transform of rectangular wave given by

Solution. $Lf(t) = \frac{\int_0^T e^{-st} f(t) dt}{1 - e^{-sT}}$

$$\begin{aligned}
 &= \frac{\int_0^{\frac{T}{2}} e^{-st} A dt + \int_{\frac{T}{2}}^T e^{-st} (-A) dt}{1 - e^{-sT}} \\
 &= \frac{\left[\frac{e^{-st}}{-s} \right]_0^{\frac{T}{2}} - \left[\frac{e^{-st}}{-s} \right]_{\frac{T}{2}}^T}{1 - e^{-sT}} \\
 &= \frac{A}{1 - e^{-sT}} \left[\frac{e^{-s \frac{T}{2}}}{s} + \frac{1}{s} - \frac{e^{-sT}}{s} + \frac{e^{-s \frac{T}{2}}}{s} \right] \\
 &= \frac{A}{s(1 - e^{-sT})} \left[1 - 2e^{-\frac{sT}{2}} + e^{-sT} \right] = \frac{A}{s(1 - e^{-sT})} \left[1 - e^{-\frac{sT}{2}} \right]^2 \\
 &= \frac{A \left[1 - e^{-\frac{sT}{2}} \right]^2}{s(1 + e^{-\frac{sT}{2}})(1 - e^{-\frac{sT}{2}})} = \frac{A \left(1 - e^{-\frac{sT}{2}} \right)}{s \left(1 + e^{-\frac{sT}{2}} \right)}
 \end{aligned}$$

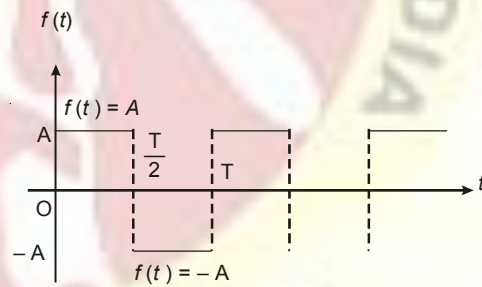

$$= \frac{A \left(\frac{e^{\frac{sT}{4}} - e^{-\frac{sT}{4}}}{e^{\frac{sT}{4}} + e^{-\frac{sT}{4}}} \right)}{s} = \frac{A}{s} \tanh \frac{sT}{4}$$

Ans.

Example 27. A periodic square wave function $f(t)$, in terms of unit step functions, is written as

$$f(t) = k[u_0(t) - 2u_a(t) + 2u_{2a}(t) - 2u_{3a}(t) + \dots]$$

Show that the Laplace transform of $f(t)$ is given by

$$L[f(t)] = \frac{k}{s} \tanh \left(\frac{as}{2} \right)$$

Solution.

$$\begin{aligned} f(t) &= k[u_0(t) - 2u_a(t) + 2u_{2a}(t) - 2u_{3a}(t) + \dots] \\ Lf(t) &= k[Lu_0(t) - 2Lu_a(t) + 2Lu_{2a}(t) - 2Lu_{3a}(t) + \dots] \\ &= k \left[\frac{1}{s} - 2 \frac{e^{-as}}{s} + 2 \frac{e^{-2as}}{s} - 2 \frac{e^{-3as}}{s} + \dots \right] \\ &= \frac{k}{s} [1 - 2e^{-as} + 2e^{-2as} - 2e^{-3as} + \dots] \\ &= \frac{k}{s} [1 - 2(e^{-as} - e^{-2as} + e^{-3as} - \dots)] \\ &= \frac{k}{s} \left[1 - 2 \frac{e^{-as}}{1 + e^{-as}} \right] = \frac{k}{s} \left[\frac{1 + e^{-as} - 2e^{-as}}{1 + e^{-as}} \right] \\ &= \frac{k}{s} \left[\frac{1 - e^{-as}}{1 + e^{-as}} \right] = \frac{k}{s} \left[\frac{e^{\frac{as}{2}} - e^{-\frac{as}{2}}}{e^{\frac{as}{2}} + e^{-\frac{as}{2}}} \right] = \frac{k}{s} \tanh \frac{as}{2} \end{aligned}$$

Ans.

Exercise 13.6

1. Find the Laplace transform of the periodic function

$$f(t) = e^t \text{ for } 0 < t < 2\pi$$

$$\text{Ans. } \frac{e^{2(1-s)\pi} - 1}{(1-s)(1 - e^{-2\pi s})}$$

2. Obtain Laplace transform of full wave rectified sine wave given by

$$f(t) = \sin \omega t, \quad 0 < t < \frac{\pi}{\omega}$$

$$\text{Ans. } \frac{\omega}{(s^2 + \omega^2)} \coth \frac{\pi s}{2\omega}$$

3. Find the Laplace transform of the staircase function

$$f(t) = kn, \quad np < t < (n+1)p, \quad n = 0, 1, 2, 3$$

$$\text{Ans. } \frac{ke^{ps}}{s(1 - e^{-ps})} \frac{2 - e^{-2s} - 4se^{-2s} - 4s^2e^{-2s}}{s^3(1 - e^{-2s})}$$

Find Laplace transform of the following:

4. $f(t) = t, \quad 0 < t < 2, \quad f(t+2) = f(t)$

$$\text{Ans. } \frac{1}{s} \frac{as}{\tanh \frac{a}{4}}$$

5. $f(t) = \begin{cases} 1, & 0 \leq t \leq \frac{a}{2} \\ -1, & \frac{a}{2} \leq t < a \end{cases}$ (U.P. II Semester, 2004)

6. $f(t) = \begin{cases} \cos \omega t, & 0 < t < \frac{\pi}{\omega} \\ 0, & \frac{\pi}{\omega} < t < \frac{2\pi}{\omega} \end{cases}$

$$\text{Ans. } \frac{s}{(s^2 + \omega^2) \left(1 - e^{-\frac{2\pi s}{\omega}} \right)}$$

Laplace Transformation

$$7. f(t) = \begin{cases} t, & 0 < t < 1 \\ 0, & 1 < t < 2 \\ \frac{2t}{T}, & 0 \leq t \leq \frac{T}{2} \end{cases} \quad f(t+2) = f(t)$$

$$8. f(t) = \begin{cases} \frac{2}{T}(T-t), & \frac{T}{2} \leq t \leq T \end{cases} \quad f(t+T) = f(t)$$

Ans. $\frac{1 - e^{-s}}{s^2(1 - e^{-2s})}$

Ans. $\frac{2}{Ts^2} \tanh \frac{sT}{4} - \frac{1}{s \left(e^{\frac{sT}{2}} + 1 \right)}$

CONVOLUTION THEOREM

If $L[f_1(t)] = F_1(s)$ and $L[f_2(t)] = F_2(s)$

then $L\left\{ \int_0^t f_1(x)f_2(t-x)dx \right\} = F_1(s).F_2(s)$

$L^{-1} F_1(s) . F_2(s) = \int_0^t f_1(x)f_2(t-x)dx$

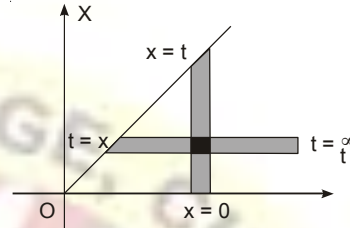

Proof. We have $L\left\{ \int_0^\infty f_1(x)f_2(t-x)dx \right\} = \int_0^\infty e^{-st} \int_0^t f_1(x)f_2(t-x)dx dt$
 $= \int_0^\infty \int_0^t e^{-st} f_1(x)f_2(t-x)dx dt$

where the double integral is taken over the infinite region in the first quadrant lying between the lines $x = 0$ and $x = t$.

On changing the order of integration, the above integral becomes

$$\int_0^\infty \int_0^t e^{-st} f_1(x)f_2(t-x)dx dt$$

$$= \int_0^\infty e^{-sx} f_1(x) dx \int_{x^\infty}^\infty e^{-s(t-x)} f_2(t-x) dt$$

$$= \int_0^\infty e^{-sx} f_1(x) dx \int_{x^\infty}^\infty e^{-sz} f_2(z) dz, \text{ on putting } t-x = z$$

$$= \int_0^\infty e^{-sx} f_1(x) F_2(s) dx = \left[\int_0^\infty e^{-sx} f_1(x) dx \right] F_2(s)$$

$$= F_1(s) F_2(s)$$

Proved.

LAPLACE TRANSFORM OF BESSEL FUNCTIONS $J_0(x)$ AND $J_1(x)$

Solution. We know that

$$J_0(t) = \left[1 - \frac{t^2}{2^2} + \frac{t^4}{2^2 \cdot 4^2} - \frac{t^6}{2^2 \cdot 4^2 \cdot 6^2} + \dots \right]$$

Taking Laplace transforms of both sides, we have

$$LJ(t) = \frac{1}{s} - \frac{1}{2^2} \frac{2!}{s^3} + \frac{1}{2^2 \cdot 4^2} \frac{4!}{s^5} - \frac{1}{2^2 \cdot 4^2 \cdot 6^2} \frac{6!}{s^7} + \dots$$

$$= \frac{1}{s} \left[1 - \frac{1}{2} \left(\frac{1}{s^2} \right) + \frac{1 \cdot 3}{2 \cdot 4} \left(\frac{1}{s^4} \right) - \frac{1 \cdot 3 \cdot 5}{2 \cdot 4 \cdot 6} \left(\frac{1}{s^6} \right) + \dots \right]$$

$$= \frac{1}{s} \left[1 + \frac{\left(\frac{1}{2} \right) \left(\frac{1}{s^2} \right)}{2!} + \frac{\left(\frac{-1}{2} \right) \left(\frac{-3}{2} \right) \left(\frac{1}{s^2} \right)^2}{3!} + \frac{\left(\frac{-1}{2} \right) \left(\frac{-3}{2} \right) \left(\frac{-5}{2} \right) \left(\frac{1}{s^2} \right)^3}{3!} + \dots \right]$$

Laplace Transformation

$$= \frac{1}{s} \left[1 + \frac{1}{s^2} \right]^{-\frac{1}{2}}$$

(By Binomial theorem)

$$= \frac{1}{\sqrt{s^2+1}}$$

Ans.

We know that

$$Lf(at) = \frac{1}{a} F\left(\frac{s}{a}\right)$$

$$\therefore LJ_0(at) = \frac{1}{a} \frac{1}{\sqrt{\frac{s^2}{a^2}+1}} = \frac{1}{\sqrt{s^2+a^2}}$$

$$LJ_1(at) = -LJ_0'(x) = -[sLJ_0(x) - J_0(0)]$$

$$= -\left[s \frac{1}{\sqrt{s^2+1}} - 1 \right] = 1 - \frac{s}{\sqrt{s^2+1}}$$

Ans.

EVALUATION OF INTEGRALS

We can evaluate number of integrals having lower limit 0 and upper limit ∞ by the help of Laplace transform.

Example 28. Evaluate $\int_0^{\infty} te^{-3t} \sin t dt$.

Solution. $\int_0^{\infty} te^{-3t} \sin t dt = \int_0^{\infty} te^{-st} \sin t dt$ (s = 3)

$$= L(t \sin t) = -\frac{d}{ds} \left(\frac{1}{s^2+1} \right) = \frac{2s}{(s^2+1)^2}$$

$$= \frac{2 \times 3}{(3^2+1)^2} = \frac{6}{100} = \frac{3}{50}$$

Ans.

Example 29. Evaluate $\int_0^{\infty} \frac{e^{-t} \sin t}{t} dt$ and $\int_0^{\infty} \frac{\sin t}{t} dt$.

Solution. $\int_0^{\infty} \frac{e^{-t} \sin t}{t} dt = \int_0^{\infty} \frac{\sin t}{t} e^{-st} dt$ (s = 1)

$$= L\left[\frac{\sin t}{t}\right] = \int_0^{\infty} \frac{1}{s+1} ds = \left[\tan^{-1} s \right]_s$$

$$= \frac{\pi}{2} - \tan^{-1} s \dots (1) = \frac{\pi}{2} - \tan^{-1}(1)$$
 (s = 1)

$$= \frac{\pi}{2} - \frac{\pi}{4} = \frac{\pi}{4}$$
 Ans.

On putting $s = 0$ in (1), we get

$$\int_0^{\infty} \frac{\sin t}{t} dt = \frac{\pi}{2} - \tan^{-1}(0) = \frac{\pi}{2}$$
 Ans.

Laplace Transformation

EXERCISE 13.7

Evaluate the following by using Laplace Transform:

$$1. \int_0^{\infty} t e^{-4t} \sin t \, dt \quad \text{Ans. } \frac{8}{289} \quad 2. \int_0^{\infty} \frac{e^{-2t} \sinh t \sin t}{t} \, dt \quad \text{Ans. } \frac{1}{2} \tan^{-1} \frac{1}{2}$$

$$3. \int_0^{\infty} \frac{\sin^2 t}{t^2} \, dt \quad \text{Ans. } i \frac{5}{2} \quad 4. \int_0^{\infty} \frac{e^{-t} - e^{-4t}}{t} \, dt \quad \text{Ans. } \log 4$$

FORMULATION OF LAPLACE TRANSFORM

S.No.	$f(t)$	$F(s)$
1.	e^{at}	$\frac{1}{s-a}$
2.	t^n	$\frac{n!}{s^{n+1}}$ or $\frac{n!}{s^{n+1}}$
3.	$\sin at$	$\frac{a}{s^2 + a^2}$
4.	$\cos at$	$\frac{s}{s^2 + a^2}$
5.	$\sinh at$	$\frac{a}{s^2 - a^2}$
6.	$\cosh at$	$\frac{s}{s^2 - a^2}$
7.	$u(t-a)$	$\frac{e^{-as}}{s}$
8.	$\delta(t-a)$	e^{-as}
9.	$e^{bt} \sin at$	$\frac{a}{(s-b)^2 + a^2}$
10.	$e^{bt} \cos at$	$\frac{s-b}{(s-b)^2 + a^2}$
11.	$\frac{t}{2a} \sin at$	$\frac{s}{(s^2 + a^2)^2}$
12.	$t \cos at$	$\frac{s^2 - a^2}{(s^2 + a^2)^2}$
13.	$\frac{1}{2a^3} (\sin at - at \cos at)$	$\frac{1}{(s^2 + a^2)^2}$
14.	$\frac{1}{2a} (\sin at + at \cos at)$	$\frac{s^2}{(s^2 + a^2)^2}$

PROPERTIES OF LAPLACE TRANSFORM

S.No.	Property	$f(t)$	$F(s)$
1.	Scaling	$f(at)$	$\frac{1}{a} F\left(\frac{s}{a}\right), \quad a > 0$
2.	Derivative	$\frac{df(t)}{dt}$	$s F(s) - f(0), \quad s > 0$
		$\frac{d^2 f(t)}{dt^2}$	$s^2 F(s) - sf(0) - f'(0), \quad s > 0$
		$\frac{d^3 f(t)}{dt^3}$	$s^3 F(s) - s^2 f(0) - sf'(0) - f''(0), \quad s > 0$
3.	Integral	$\int_0^t f(t) dt$	$\frac{1}{s} F(s), \quad s > 0$
4.	Initial Value	$\lim_{t \rightarrow 0} f(t)$	$\lim_{s \rightarrow \infty} sF(s)$
5.	Final Value	$\lim_{t \rightarrow \infty} f(t)$	$\lim_{s \rightarrow 0} sF(s)$
6.	First shifting	$e^{-at} f(t)$	$F(s+a)$
7.	Second shifting	$f(t) u(t-a)$	$e^{-as} Lf(s+a)$
8.	Multiplication by t	$tf(t)$	$-\frac{d}{ds} F(s)$
9.	Multiplication by t^n	$t^n f(t)$	$(-1)^n \frac{d^n}{ds^n} F(s)$
10.	Division by t	$\frac{1}{t} f(t)$	$\int_s^\infty F(s) ds$
11.	Periodic function	$f(t)$	$\frac{\int_0^T e^{-st} f(t) dt}{1 - e^{-sT}}, \quad f(t+T) = f(t)$
12.	Convolution	$f(t) * g(t)$	$F(s) G(s)$

INVERSE LAPLACE TRANSFORMS

Now we obtain $f(t)$ when $F(s)$ is given, then we say that inverse Laplace transform of $F(s)$ is $f(t)$.

If $L[f(t)] = F(s)$ then $L^{-1}[F(s)] = f(t)$.

where L^{-1} is called the inverse Laplace transform operator.

From the application point of view, the inverse Laplace transform is very useful.

Laplace Transformation

IMPORTANT FORMULAE

1. $L^{-1} \left(\frac{1}{s} \right) = 1$
2. $L^{-1} \frac{1}{s^n} = \frac{t^{n-1}}{(n-1)!}$
3. $L^{-1} \frac{1}{s-a} = e^{at}$
4. $L^{-1} \frac{s}{s^2 - a^2} = \cosh at$
5. $L^{-1} \frac{1}{s^2 - a^2} = \frac{1}{a} \sinh at$
6. $L^{-1} \frac{1}{s^2 + a^2} = \frac{1}{a} \sin at$
7. $L^{-1} \frac{s}{s^2 + a^2} = \cos at$
8. $L^{-1} F(s-a) = e^{at} f(t)$
9. $L^{-1} \frac{1}{(s-a)^2 + b^2} = \frac{1}{b} e^{at} \sin bt$
10. $L^{-1} \frac{s-a}{(s-a)^2 + b^2} = e^{at} \cos bt$
11. $L^{-1} \frac{1}{(s-a)^2 - b^2} = \frac{1}{b} e^{at} \sinh bt$
12. $L^{-1} \frac{s-a}{(s-a)^2 - b^2} = e^{at} \cosh bt$
13. $L^{-1} \frac{1}{(s^2 + a^2)^2} = \frac{1}{2a^3} (\sin at - at \cos at)$
14. $L^{-1} \frac{s}{(s^2 + a^2)^2} = \frac{1}{2a} t \sin at$
15. $L^{-1} \frac{1}{(s^2 + a^2)^2} = t \cos at$
16. $L^{-1} (1) = s(t)$
17. $L^{-1} \frac{1}{s^2 - a^2} = \frac{1}{2a} [\sin at + at \cos at]$
18. $L^{-1} \left\{ \frac{1}{s} F(s) \right\} = \int_0^t f(t) dt$

Example 30. Find the inverse Laplace Transform of the following:

- (i) $\frac{1}{s-2}$ (ii) $\frac{1}{s^2-9}$ (iii) $\frac{s}{s^2-16}$ (iv) $\frac{1}{s^2+25}$ (v) $\frac{s}{s^2+9}$
 (vi) $\frac{1}{(s-2)^2+1}$ (vii) $\frac{s-1}{(s-1)^2+4}$ (viii) $\frac{1}{(s+3)^2-4}$ (ix) $\frac{s+2}{(s+2)^2-25}$ (x) $\frac{1}{2s-7}$

Solution. (i) $L^{-1} \frac{1}{s-2} = e^{2t}$ (ii) $L^{-1} \frac{1}{s^2-9} = L^{-1} \frac{1}{3(s^2-(3)^2)} = \frac{1}{3} \sinh 3t$

(iii) $L^{-1} \frac{s}{s^2-16} = L^{-1} \frac{s}{s^2-(4)^2} = \cosh 4t$ (iv) $L^{-1} \frac{1}{s^2+25} = \frac{1}{5} \frac{5}{s^2+(5)^2} = \frac{1}{5} \sin 5t$

(v) $L^{-1} \frac{s}{s^2+9} = \frac{s}{s^2+(3)^2} = \cos 3t$ (vi) $L^{-1} \frac{1}{(s-2)^2+1} = e^{2t} \sin t$

(vii) $L^{-1} \frac{s-1}{(s-1)^2+4} = e^t \cos 2t$ (viii) $L^{-1} \frac{1}{(s+3)^2-4} = \frac{1}{2} \frac{2}{(s+3)^2-(2)^2} = \frac{1}{2} e^{-3t} \sinh 2t$

(ix) $L^{-1} \frac{s+2}{(s+2)^2-25} = L^{-1} \frac{(s+2)}{(s+2)^2-(5)^2} = e^{-2t} \cosh 5t$

(x) $L^{-1} \frac{1}{2s-7} = \frac{1}{2} e^{\frac{7}{2}t}$ $\left[L^{-1} F(as) = \frac{1}{a} f\left(\frac{t}{a}\right) \right]$

Ans.

Example 31. Find the inverse Laplace transform of

- (i) $\frac{1}{s^{3/2}}$ (ii) $\frac{2s-5}{9s^2-25}$ (iii) $\frac{s-2}{6s^2+20}$

Solution. (i) $L^{-1} \frac{1}{s^{3/2}} = L^{-1} s^{-1/2} + L^{-1} s^{-1/2} + L^{-1} \frac{2}{s^{3/2}}$

$$\begin{aligned}
 &= L^{-1} \frac{1}{s^{-1/2}} + L^{-1} \frac{1}{s^{1/2}} + L^{-1} \frac{2}{s^{3/2}} = \frac{t^{-1/2-1}}{\left| \frac{-1}{2} \right|} + \frac{t^{1/2-1}}{\left| \frac{-1}{2} \right|} + \frac{2t_{3/2-1}}{\left| \frac{-3}{2} \right|} \quad \text{Laplace Transformation} \\
 &= \frac{1}{\left| \frac{-1}{2} \right|} t^{3/2} + \frac{1}{\sqrt{\pi t}} + \frac{4\sqrt{t}}{\sqrt{\pi}}
 \end{aligned}$$

Ans.

$$\begin{aligned}
 \text{(ii)} \quad L^{-1} \frac{2s-5}{9s^2-25} &= L^{-1} \left[\frac{2s}{9s^2-25} - \frac{5}{9s^2-25} \right] = L^{-1} \left[\frac{2s}{9 \left[s^2 - \left(\frac{5}{3} \right)^2 \right]} - \frac{5}{9 \left[s^2 - \left(\frac{5}{3} \right)^2 \right]} \right] \\
 &= \frac{2}{9} \cosh \frac{5}{3} t - \frac{1}{3} L^{-1} \left[\frac{5}{\left(\frac{5}{3} \right)^2} \right] = \frac{2}{9} \cosh \frac{5t}{3} - \frac{1}{3} \sin \frac{5t}{3}
 \end{aligned}$$

Ans.

$$\begin{aligned}
 \text{(iii)} \quad L^{-1} \frac{s-2}{6s^2+20} &= L^{-1} \frac{s}{6s^2+20} - L^{-1} \frac{2}{6s^2+20} = \frac{1}{6} L^{-1} \frac{s}{s^2+\frac{10}{3}} - \frac{1}{3} L^{-1} \frac{1}{s^2+\frac{10}{3}} \\
 &= \frac{1}{6} \cos \sqrt{\frac{10}{3}} t - \frac{1}{3} \times \sqrt{\frac{3}{10}} L^{-1} \frac{\sqrt{\frac{10}{3}}}{s^2+\frac{10}{3}} = \frac{1}{6} \cos \sqrt{\frac{10}{3}} t - \frac{1}{\sqrt{30}} \sin \sqrt{\frac{10}{3}} t
 \end{aligned}$$

Ans.

Exercise 13.8

Find the inverse Laplace transform of the following:

$$\begin{array}{ll}
 \text{1. } \frac{3s-8}{4s^2+25} & \text{Ans. } \frac{3}{4} \cos \frac{5t}{2} - \frac{4}{5} \sin \frac{5t}{2} \\
 \text{2. } \frac{3(s^2-2)^2}{2s^5} & \text{Ans. } \frac{3}{2} - 3t^2 + \frac{1}{2} t^4 \\
 \text{3. } \frac{2s-5}{4s^2+25} + \frac{4s-18}{9-s^2} & \text{Ans. } \frac{1}{2} \left(\cos \frac{5t}{2} - \sin \frac{5t}{2} \right) - 4 \cosh 3t + 6 \sinh 3t \\
 \text{4. } \frac{5s-10}{9s^2-16} & \text{Ans. } \frac{5}{9} \cosh \frac{4t}{3} - \frac{5}{6} \sinh \frac{4t}{3} \\
 \text{5. } \frac{1}{4s} + \frac{16}{1-s^2} & \text{Ans. } \frac{1}{4} - 16 \sinh t
 \end{array}$$

MULTIPLICATION by s

$$L^{-1}[sF(s)] = \frac{d}{dt} f(t) + f(0)\delta(t)$$

Example 32. Find the inverse Laplace transform of

$$\begin{array}{lll}
 \text{(i)} \quad \frac{s}{s^2+1} & \text{(ii)} \quad \frac{s}{4s^2-25} & \text{(iii)} \quad \frac{3s}{2s+9}
 \end{array}$$

$$\begin{aligned}
 \text{Solution. (i)} \quad L^{-1} \frac{1}{s^2+1} &= \sin t \\
 L^{-1} \frac{s}{s^2+1} &= \frac{d}{dt} (\sin t) + \sin(0)\delta(t) \\
 &= \cos t
 \end{aligned}$$

Ans.

$$\text{(ii)} \quad L^{-1} \frac{1}{4s^2-25} = \frac{1}{4} L^{-1} \frac{1}{s^2-\frac{25}{4}} = \frac{1}{4} \cdot \frac{2}{5} L^{-1} \frac{\frac{5}{2}}{s^2-\left(\frac{5}{2}\right)^2} = \frac{1}{10} \sinh \frac{5}{2} t$$

Laplace Transformation

$$\begin{aligned} L^{-1} \frac{s}{4s^2 - 25} &= \frac{1}{10} \frac{d}{dt} \sinh \frac{5}{2}t + \frac{1}{10} \sinh \frac{5}{2}(0) \\ &= \frac{1}{10} \left(\frac{5}{2} \right) \cosh \frac{5}{2}t = \frac{1}{4} \cosh \frac{5}{2}t \end{aligned}$$

Ans.

$$(iii) \quad L^{-1} \frac{3}{2s+9} = \frac{3}{2} L^{-1} \frac{1}{s+\frac{9}{2}} = \frac{3}{2} e^{-9/2t}$$

$$\begin{aligned} L^{-1} \frac{3s}{2s+9} &= \frac{3}{2} \frac{d}{dt} (e^{-9/2t}) + \frac{3}{2} e^{-9/2(0)} = \frac{3}{2} \left(-\frac{9}{2} \right) e^{-9/2t} + \frac{3}{2} \\ &= -\frac{27}{4} e^{-9/2t} + \frac{3}{2} \end{aligned}$$

Ans.

Exercise 13.9

Find the inverse Laplace transform of the following:

1. $\frac{s}{s+5}$

Ans. $-5e^{-5t}$

2. $\frac{2s}{3s+6}$

Ans. $-\frac{4}{3}e^{-2t}$

3. $\frac{s}{2s^2-1}$
 $\frac{s^2+4}{s^2+4}$

Ans. $\frac{1}{2} \cosh \frac{t}{2}$
 $\frac{5}{3} \sin 3t + 1$

4. $\frac{s^2}{s^2+a^2}$
 $\frac{1}{(s-3)^2}$

Ans. $-a \sin at + 1$

5. $\frac{s^2}{s^2+9}$

Ans. $-\frac{5}{3} \sin 3t + 1$

6. $\frac{1}{(s-3)^2}$ (Madras, 2006)

Ans. e^{3t}

7. $L^{-1} \frac{s^2}{(s^2+4)^2}$ is

(i) $\sin 2t + \frac{t}{2} \cos 2t$ (ii) $\frac{1}{4} \sin 2t + \frac{t}{2} \cos 2t$ (iii) $\frac{1}{4} \sin 2t + t \cos 2t$ (iv) $\frac{1}{4} \sin 2t + \frac{t}{4} \cos 2t$

Ans. (ii)

DIVISION BY s (multiplication by $\frac{1}{s}$)

$$L^{-1} \left[\frac{F(s)}{s} \right] = \int_0^t L^{-1}[F(s)] dt = \int_0^t f(t) dt$$

Example 33. Find the inverse Laplace transform of

(i) $\frac{1}{s(s+a)}$

(ii) $\frac{1}{s(s^2+1)}$

(iii) $\frac{s^2+3}{s(s^2+9)}$

Solution. (i) $L^{-1} \left(\frac{1}{s(s+a)} \right) = e^{-at}$

$$\begin{aligned} L^{-1} \left[\frac{1}{s(s+a)} \right] &= \int_0^t L^{-1} \left(\frac{1}{s+a} \right) dt = \int_0^t e^{-at} dt = \left[\frac{e^{-at}}{-a} \right]_0^t \\ &= \frac{e^{-at}}{-a} + \frac{1}{a} = \frac{1}{a} [1 - e^{-at}] \end{aligned}$$

Ans.

(ii)

$$L^{-1} \frac{1}{s(s^2+1)} = \sin t$$

$$L^{-1} \left[\frac{1}{s(s^2+1)} \right] = \int_0^t L^{-1} \left(\frac{1}{s^2+1} \right) dt = \int_0^t \sin t dt = [-\cos t]_0^t = -\cos t + 1$$

Ans.

Laplace Transformation

$$\begin{aligned}
 \text{(iii)} \quad \mathcal{L}^{-1} \frac{-s^2+3}{s(s^2+9)} &= \mathcal{L}^{-1} \left[\frac{[s^2+9-6]}{s(s^2+9)} \right] = \mathcal{L}^{-1} \left[\frac{1}{s} - \frac{6}{s(s^2+9)} \right] \\
 &= 1 - 2 \int_0^t \sin 3t \, dt = 1 - \int_0^t \mathcal{L}^{-1} \left(\frac{6}{s^2+9} \right) ds = 1 + 2 \times \frac{1}{3} [\cos 3t]_0^t = 1 + \frac{2}{3} \cos 3t - \frac{2}{3} \\
 &= \frac{2}{3} \cos 3t + \frac{1}{3} = \frac{1}{3} [2 \cos 3t + 1] \quad \text{Ans.}
 \end{aligned}$$

Exercise 13.10

Find the inverse Laplace transform of the following:

1. $\frac{1}{2s(s-3)}$ Ans. $\frac{1}{2} \left[\frac{e^{3t}}{3} - 1 \right]$ 2. $\frac{1}{s(s+2)}$ Ans. $\frac{1-e^{-2t}}{2}$
3. $\frac{1}{s(s^2-16)}$ Ans. $\frac{1}{16} [\cosh 4t - 1]$ 4. $\frac{1}{s(s^2+a^2)}$ Ans. $\frac{1-\cos at}{a^2}$
5. $\frac{s^2+2}{s(s^2+4)}$ Ans. $\cos^2 t$ 6. $\frac{1}{s^2(s+1)}$ Ans. $t - 1 + e^{-t}$
7. $\mathcal{L}^{-1} \frac{s^2}{s(s^2+1)}$ Ans. $\frac{t^2}{2} + \cos t - 1$
8. $\mathcal{L}^{-1} \frac{s^2}{s(s^2+1)}$ is
 (i) $1 - \cos t$ (ii) $1 + \cos t$ (iii) $1 - \sin t$ (iv) $1 + \sin t$ Ans. (i)

FIRST SHIFTING PROPERTY

If $\mathcal{L}^{-1} F(s) = f(t)$ then $\mathcal{L}^{-1} F(s+a) = e^{-at} \mathcal{L}^{-1} [F(s)]$

Example 34. Find the inverse Laplace transform of

- (i) $\frac{1}{(s+2)^5}$ (ii) $\frac{s}{s^2+4s+13}$ (iii) $\frac{1}{9s^2+6s+1}$ (iv) $\frac{s-1}{s^2-6s+25}$ (v) $\frac{s-1}{s^2-6s+25}$

Solution. (i) $\mathcal{L}^{-1} \frac{1}{s^5} = \frac{t^4}{4!}$

then $\mathcal{L}^{-1} \frac{1}{(s+2)^5} = e^{-2t} \frac{t^4}{4!}$ Ans.

(ii) $\mathcal{L}^{-1} \left(\frac{s}{s^2+4s+13} \right) = \mathcal{L}^{-1} \left(\frac{s+2-2}{(s+2)^2+(3)^2} \right) = \mathcal{L}^{-1} \left(\frac{s+2}{(s+2)^2+(3)^2} \right) - \mathcal{L}^{-1} \left(\frac{2}{(s+2)^2+(3)^2} \right)$
 $= e^{-2t} \mathcal{L}^{-1} \left(\frac{s}{s^2+3^2} \right) = e^{-2t} \mathcal{L}^{-1} \left(\frac{3 \left(\frac{s}{3^2+3^2} \right)}{3} \right) = e^{-2t} \cos 3t - \frac{2}{3} e^{-2t} \sin 3t$ Ans.

(iii) $\mathcal{L}^{-1} \frac{1}{9s^2+6s+1} = \mathcal{L}^{-1} \frac{1}{(3s+1)^2} = \frac{1}{9} \mathcal{L}^{-1} \left(\frac{1}{\left(s + \frac{1}{3} \right)^2} \right) = \frac{1}{9} e^{-t/3} \mathcal{L}^{-1} \left(\frac{1}{s^2} \right) = \frac{1}{9} e^{-t/3} t = \frac{te^{-t/3}}{9}$ Ans.

(iv) $\mathcal{L}^{-1} \left(\frac{s-1}{s^2-6s+25} \right) = \mathcal{L}^{-1} \left[\frac{s-1}{(s-3)^2+(4)^2} \right] = \mathcal{L}^{-1} \left[\frac{s-3+2}{(s-3)^2+(4)^2} \right]$
 $= \mathcal{L}^{-1} \left[\frac{s-3}{(s-3)^2+(4)^2} \right] + \frac{1}{2} \mathcal{L}^{-1} \left[\frac{4}{(s-3)^2+(4)^2} \right]$
 $= e^{3t} \cos 4t + \frac{1}{2} e^{3t} \sin 4t$ Ans.

Laplace Transformation

Exercise 13.11

Obtain the inverse Laplace transform of the following:

- | | | | |
|------------------------------|--|----------------------------|---------------------------------------|
| 1. $\frac{s+8}{s^2+4s+5}$ | Ans. $e^{-2t}(\cos t + 6 \sin t)$ | 2. $\frac{s}{(s+3)^2+4}$ | Ans. $e^{-3t}(\cos 2t - 1.5 \sin 2t)$ |
| 3. $\frac{s}{(s+7)^4}$ | Ans. $e^{-7t} \frac{t^2}{6}(3-7t)$ | 4. $\frac{1}{s^2-2s-8}$ | Ans. $e^t(\cosh 3t + \sinh 3t)$ |
| 5. $\frac{s}{s^2+6s+25}$ | Ans. $e^{-3t} \left[\cos 4t - \frac{3}{4} \sin 4t \right]$ | 6. $\frac{1}{2(s-1)^2+32}$ | Ans. $\frac{e^t}{8} \sin 4t$ |
| 7. $\frac{s-4}{4(s-3)^2+16}$ | Ans. $\frac{1}{4} e^{3t} \cos 2t - \frac{1}{8} e^{3t} \sin 2t$ | | |

SECOND SHIFTING PROPERTY

$$L^{-1}[e^{-as} F(s)] = f(t-a)U(t-a)$$

Example 35. Obtain inverse Laplace transform of

(i) $\frac{e^{-\pi s}}{(s+3)}$ (ii) $\frac{e^{-s}}{(s+1)^3}$

Solution. (i) $L^{-1} \frac{1}{s+3} = e^{-3t}$

$\Rightarrow L^{-1} \frac{e^{-\pi s}}{s+3} = e^{-3(t-\pi)} U(t-\pi)$ **Ans.**

(ii) $L^{-1} \frac{1}{s^3} = \frac{t^2}{2!}$

$\Rightarrow L^{-1} \frac{1}{(s+1)^3} = e^{-t} \frac{t^2}{2!}$

$\Rightarrow L^{-1} \frac{e^{-s}}{(s+1)^3} = e^{-(t-1)} \cdot \frac{(t-1)^2}{2!} \cdot U(t-1)$ **Ans.**

Example 36. Find the inverse Laplace transform of $\frac{se^{-s/2} + \pi e^{-s}}{s^2 + \pi^2}$ in terms of unit step functions.

Solution. $L^{-1} \frac{\pi}{s^2 + \pi^2} = \sin \pi t$
 $L^{-1} \left[\frac{e^{-s}}{s^2 + \pi^2} \right] = \sin \pi(t-1) \cdot u(t-1) = -\sin(\pi t) \cdot u(t-1)$... (1)

and $L^{-1} \frac{s}{s^2 + \pi^2} = \cos \pi t$
 $L^{-1} \left[\frac{e^{-s/2} s}{s^2 + \pi^2} \right] = \cos \pi \left(t - \frac{1}{2} \right) \cdot u \left(t - \frac{1}{2} \right) = \sin \pi t \cdot u \left(t - \frac{1}{2} \right)$... (2)

On adding (1) and (2), we get

$$L^{-1} \left[\frac{e^{-s/2} s + e^{-s} \cdot \pi}{s^2 + \pi^2} \right] = \sin(\pi t) \cdot u \left(t - \frac{1}{2} \right) - \sin(\pi t) \cdot u(t-1)$$

$$= \sin \pi \left[u \left(t - \frac{1}{2} \right) - u(t-1) \right]$$

Ans.

Example 37. Find the value of $L^{-1} \left\{ \frac{1}{(s^2 + a^2)^2} \right\}$.

Solution.

$$\frac{1}{(s^2 + a^2)^2} = \frac{1}{s} \cdot \frac{s}{(s^2 + a^2)^2} = -\frac{1}{2s} \frac{d}{ds} \left(\frac{1}{s^2 + a^2} \right)$$

$$\Rightarrow L^{-1} \left\{ \frac{1}{(s^2 + a^2)^2} \right\} = L^{-1} \left\{ -\frac{1}{2s} \frac{d}{ds} \left(\frac{1}{s^2 + a^2} \right) \right\}$$

$$= -\frac{1}{2s} L^{-1} \left\{ \frac{d}{ds} \left(\frac{1}{s^2 + a^2} \right) \right\} = \frac{1}{2a} \cdot \frac{1}{s} [t \sin at]$$

$$= \frac{1}{2a} \int_0^t t \sin at \, dt = \frac{1}{2a} \left[t \left(-\frac{\cos at}{-a} \right) - \int \left(-\frac{\cos at}{a} \right) dt \right]_0^t$$

$$= \frac{1}{2a} \left[-\frac{t}{a} \cos at + \frac{\sin at}{a^2} \right]_0^t$$

$$= \frac{1}{2a^3} [-at \cos at + \sin at]$$

Ans.

Exercise 13.12

Obtain inverse Laplace transform of the following:

1. $\frac{e^{-s}}{(s+2)^3}$

Ans. $e^{-2t} \frac{(t-2)^2}{2} U(t-2)$

2. $\frac{e^{-2s}}{(s+1)(s^2+2s+2)}$

Ans. $e^{-(t-2)} \{1 - \cos(t-2)\} u(t-2)$

3. $\frac{e^{-s}}{\sqrt{s+1}}$

Ans. $\frac{e^{-(t-1)}}{\sqrt{\pi(t-1)}} U(t-1)$

4. $\frac{e^{-\frac{\pi}{2}s}}{e^{-\frac{\pi}{2}s} + e^{-\frac{3\pi}{2}s}}$

Ans. $\cot t \left[U \left(t - \frac{3\pi}{2} \right) - U \left(t - \frac{\pi}{2} \right) \right]$

5. $\frac{s^2+1}{e^{-4s}(s+2)}$

Ans. $e^{-2(t-u)} \cos(t-u) U(t-4)$

6. $\frac{e^{-as}}{s^2}$

Ans. $f(t) = t - a$ when $t > a$
 $= 0$ when $t < a$

7. $\frac{e^{-\pi s}}{s^2+1}$

Ans. $-\sin t \cdot u(t - \pi)$

Tick (✓) the correct answers:

8. (a) The inverse Laplace transform of $(e^{-3s})/s^3$, is

(i) $(t-3)u_3(t)$ (ii) $(t-3)^2 u_3(t)$ (iii) $(t-3)u_3(t)$ (iv) $(t+3)^2 u_3(t)$ **Ans.** (iv)

(b) If Laplace transform of a function $f(t)$ equals $(e^{-2s} - e^{-s})/s$, then

- (i) $f(t) = 1, t > 1$;
 (ii) $f(t) = 1$, when $1 < t < 2$, and 0 otherwise ;
 (iii) $f(t) = -1$, when $1 < t < 3$, and 0 otherwise ;
 (iv) $f(t) = -1$, when $1 < t < 2$, and 0 otherwise.

Ans. (iv)

Laplace Transformation

- (c) The Laplace inverse $L^{-1} \left[\frac{2(e^{-2s} - e^{-4s})}{s} \right]$ equals
 (i) 2, if $0 < t < 4$; 0 otherwise, (ii) 2, if $t > 0$
 (iii) 2, if $0 < t < 2$; 0 otherwise, (iv) 2, if $2 < t < 4$; 0 otherwise **Ans. (iv)**
- (d) The Laplace transform of $tu_2(t)$ is
 (i) $\left(\frac{1}{s^2} + \frac{2}{s} \right) e^{-2s}$ (ii) $\frac{1}{s^2} e^{-2s}$ (iii) $\left(\frac{1}{s^2} - \frac{2}{s} \right) e^{-2s}$ (iv) $\frac{1}{s^2} e^{-2s}$ **Ans. (i)**
- (e) The inverse Laplace transform of $\frac{Ke^{-as}}{S^2 + k^2}$ is
 (i) $\sin kt$ (ii) $\cos kt$ (iii) $u(t-a) \sin kt$ (iv) none of these. **Ans. (iv)**
- (f) Inverse Laplace's transform of 1 is:
 (i) 1 (ii) $\delta(t)$ (iii) $\delta(t-1)$ (iv) $u(t)$ **Ans. (ii)**

INVERSE LAPLACE TRANSFORMS OF DERIVATIVES

$$L^{-1} \left[\frac{d}{ds} F(s) \right] = -t L^{-1} [F(s)] = -tf(t) \quad \text{or} \quad L \left[\frac{d}{ds} F(s) \right] = -L^{-1} [F(s)]$$

Example 38. Find inverse Laplace transform of $\tan^{-1} \frac{1}{s}$

Solution.

$$\begin{aligned} L^{-1} \left[\tan^{-1} \frac{1}{s} \right] &= \frac{1}{t} L^{-1} \left[\frac{d}{ds} \tan^{-1} \frac{1}{s} \right] \\ &= -\frac{1}{t} L^{-1} \left[\frac{1}{1 + \frac{1}{s^2}} \left(-\frac{1}{s^2} \right) \right] = -\frac{1}{t} L^{-1} \left[\frac{1}{1 + s^2} \right] \\ &= \frac{\sin t}{t} \end{aligned}$$

Ans.

Example 39. Obtain the inverse Laplace transform of $\log \frac{s^2 - 1}{s^2}$.

Solution.

$$\begin{aligned} L^{-1} \left[\log \frac{s^2 - 1}{s^2} \right] &= -\frac{1}{t} L^{-1} \left[\frac{d}{ds} \log \frac{s^2 - 1}{s^2} \right] \\ &= -\frac{1}{t} L^{-1} \left[\frac{2s}{s^2 - 1} - \frac{2}{s} \right] = -\frac{1}{t} [2 \cosh t - 2] \\ &= \frac{2}{t} [1 - \cosh t] \end{aligned}$$

Example 40. Find $L^{-1} [\cot^{-1}(1+s)]$.

Solution.

$$\begin{aligned} L^{-1} [\cot^{-1}(1+s)] &= -\frac{1}{t} L^{-1} \left[\frac{d}{ds} \cot^{-1}(1+s) \right] \\ &= -\frac{1}{t} L^{-1} \left[\frac{-1}{1 + (s+1)^2} \right] = \frac{1}{t} L^{-1} \left[\frac{1}{(s+1)^2 + 1} \right] \\ &= \frac{1}{t} e^{-t} \sin t \end{aligned}$$

Ans.

Exercise 13.13

Obtain inverse Laplace transform of the following:

1. $\log\left(1 + \frac{\omega^2}{s^2}\right)$ **Ans.** $\frac{2}{t} \cos \omega t + 2$ 2. $\frac{s}{1+s^2+s^4}$ **Ans.** $\frac{2}{\sqrt{3}} \sin \frac{\sqrt{3}}{2} t \sinh \frac{t}{2}$
3. $\frac{s}{(s^2+a^2)^2}$ **Ans.** $\frac{t \sin at}{2a}$ 4. $s \log \frac{s}{\sqrt{s^2+1}} + \cot^{-1} s$ **Ans.** $\frac{1-\cos t}{t^2}$
5. $\frac{1}{2} \log \left\{ \frac{s^2+b^2}{(s-a)^2} \right\}$ **Ans.** $\frac{e^{-at} - \cos bt}{t}$ 6. $\tan^{-1}(s+1)$ **Ans.** $-\frac{1}{t} e^{-t} \sin t$

INVERSE LAPLACE TRANSFORM OF INTEGRALS

$$\mathcal{L}^{-1} \left[\int_s^\infty f(s) ds \right] = \frac{f(t)}{t} = \frac{1}{t} \mathcal{L}^{-1} [F(s)] \quad \text{or} \quad \mathcal{L}^{-1} [F(s)] = t \mathcal{L}^{-1} \left[\int_s^\infty F(s) ds \right]$$

Example 41. Obtain $\mathcal{L}^{-1} \frac{2s}{(s^2+1)^2}$.

Solution. $\mathcal{L}^{-1} \frac{2s}{(s^2+1)^2} = -t \mathcal{L}^{-1} \int_s^\infty \frac{2s ds}{(s^2+1)^2} = t \mathcal{L}^{-1} \left[-\frac{1}{s^2+1} \right]_\infty = t \mathcal{L}^{-1} \left[-0 + \frac{1}{s^2+1} \right]$

$$= t \sin t$$

Ans.

PARTIAL FRACTIONS METHOD

Example 42. Find the inverse transforms of

$$\frac{1}{s^2-5s+6}$$

Solution. Let us convert the given function into partial fractions.

$$\begin{aligned} \mathcal{L}^{-1} \left[\frac{1}{s^2-5s+6} \right] &= \mathcal{L}^{-1} \left[\frac{1}{s-3} - \frac{1}{s-2} \right] \\ &= \mathcal{L}^{-1} \left(\frac{1}{s-3} \right) - \mathcal{L}^{-1} \left(\frac{1}{s-2} \right) = e^{3t} - e^{2t} \end{aligned}$$

Ans.

Example 43. Find the inverse Laplace transforms of $\frac{s+4}{s(s-1)(s^2+4)}$

Solution. Let us first resolve $\frac{s+4}{s(s-1)(s^2+4)}$ into partial fractions.

$$\frac{s+4}{s(s-1)(s^2+4)} \equiv \frac{A}{s} + \frac{B}{s-1} + \frac{Cs+D}{s^2+4} \quad \dots(1)$$

$$s+4 \equiv A(s-1)(s^2+4) + Bs(s^2+4) + (Cs+D)s(s-1)$$

Putting $s = 0$, we get $4 = -4A$ or $A = -1$

Putting $s = 1$, we get $5 = B \cdot 1 \cdot (1+4) \Rightarrow B = 1$

Equating the coefficients of s^3 on both sides of (1), we have

$$0 = A + B + C \Rightarrow 0 = -1 + 1 + C \Rightarrow C = 0.$$

Equating the coefficients of s on both sides of (1), we get

$$1 = 4A + 4B - D \Rightarrow 1 = -4 + 4 - D \Rightarrow D = -1$$

On putting the values of A, B, C, D in (1), we get

$$\frac{s+4}{s(s-1)(s^2+4)} = -\frac{1}{s} + \frac{1}{s-1} - \frac{1}{s^2+4}$$

Laplace Transformation

$$\begin{aligned} L^{-1}\left[\frac{s+4}{s(s-1)(s^2+4)}\right] &= L^{-1}\left[-\frac{1}{s} + \frac{1}{s-1} - \frac{1}{s^2+4}\right] \\ \therefore L^{-1}\left[\frac{s+4}{s(s-1)(s^2+4)}\right] &= -L^{-1}\left[\frac{1}{s}\right] + L^{-1}\left[\frac{1}{s-1}\right] - L^{-1}\left[\frac{1}{s^2+4}\right] \\ &= -L^{-1}\left[\frac{1}{s}\right] + L^{-1}\left[\frac{1}{s-1}\right] - \frac{1}{2}L^{-1}\left[\frac{2}{s^2+2^2}\right] \\ &= -1 + e^t - \frac{1}{2}\sin 2t \end{aligned}$$

Ans.**Example 44.** Find the Laplace inverse of

$$\frac{s^2}{(s^2+a^2)(s^2+b^2)}$$

Solution. Let us convert the given function into partial fractions.

$$\begin{aligned} L^{-1}\left[\frac{s^2}{(s^2+a^2)(s^2+b^2)}\right] &= L^{-1}\left[\frac{1}{a^2} - \frac{1}{b^2} + \frac{1}{s^2+a^2} - \frac{1}{s^2+b^2}\right] \\ &= \frac{1}{a^2-b^2}L^{-1}\left[\frac{s^2+a^2}{s^2+a^2} - \frac{s^2+b^2}{s^2+b^2}\right] \\ &= \frac{1}{a^2-b^2}L^{-1}\left[\frac{1}{s^2+a^2} - \frac{1}{s^2+b^2}\right] = \frac{1}{a^2-b^2}\left[a^2\left(\frac{1}{a}\sin at\right) - b^2\left(\frac{1}{b}\sin bt\right)\right] \\ &= \frac{1}{a^2-b^2}[a \sin at - b \sin bt] \end{aligned}$$

Ans.**Exercise 13.14**

Find the inverse transform of:

1. $\frac{s^2+2s+6}{s^3}$ **Ans.** $1+2t+3t^2$
2. $\frac{1}{s^2-7s+12}$ **Ans.** $e^{4t}-e^{3t}$
3. $\frac{s+2}{s^2-4s+13}$ **Ans.** $e^{2t}\cos 3t + \frac{4}{3}e^{2t}\sin 3t$
4. $\frac{3s+1}{(s-1)(s^2+1)}$ **Ans.** $e^t - 2\cos t + \sin t$
5. $\frac{11s^2-2s+5}{2s^3-3s^2-3s+2}$ **Ans.** $2e^{-t} + 5e^{2t} - \frac{3}{2}e^{t/2}$
6. $\frac{2s^2-6s+5}{(s-1)(s-2)(s-3)}$ **Ans.** $\frac{1}{2}e^t - e^{2t} + \frac{5}{2}e^{3t}$
7. $\frac{s-4}{(s-4)^2+9}$ **Ans.** $e^{4t}\cos 3t$
8. $\frac{16}{(s^2+2s+5)^2}$ **Ans.** $e^{-t}(\sin 2t - 2t \cos 2t)$
9. $\frac{1}{(s+1)(s^2+2s+2)}$ **Ans.** $e^{-t}(1-\cos t)$
10. $\frac{1}{(s-2)(s^2+1)}$ **Ans.** $\frac{1}{5}e^{2t} - \frac{1}{5}\cos t - \frac{2}{5}\sin t$
11. $\frac{s^2-6s+7}{(s^2-4s+5)^2}$ **Ans.** $e^{2t}[t \cos t - \sin t]$

INVERSE LAPLACE TRANSFORM BY CONVOLUTION

$$L\left\{\int_0^t f_1(x) * f_2(t-x) dx\right\} = F_1(s) \cdot F_2(s) \Rightarrow \int_0^t f_1(x) \cdot f_2(t-x) dx = L^{-1}F_1(s) \cdot F_2(s)$$

Example 45. Using the convolution theorem, find

$$L^{-1}\left\{\frac{s^2}{(s^2+a^2)(s^2+b^2)}\right\}, a \neq b$$

Solution. We have

$$L(\cos at) = \frac{s}{s^2+a^2} \quad \text{and} \quad L(\cos bt) = \frac{s}{s^2+b^2}$$

Hence by the convolution theorem

$$L\left\{\int_0^t \cos ax \cos b(t-x) dx\right\} = \frac{s^2}{(s^2+a^2)(s^2+b^2)}$$

Therefore,

$$\begin{aligned} L^{-1}\left\{\frac{s^2}{(s^2+a^2)(s^2+b^2)}\right\} &= \int_0^t \cos ax \cos b(t-x) dx \\ &= \frac{1}{2} \int_0^t \{\cos(ax+bt-bx) + \cos(ax-bt+bx)\} dx \\ &= \frac{1}{2} \int_0^t \cos[(a-b)x+bt] dx + \frac{1}{2} \int_0^t \cos[(a+b)x-bt] dx \\ &= \left[\frac{\sin[(a-b)x+bt]}{2(a-b)} \right]_0^t + \left[\frac{\sin[(a+b)x-bt]}{2(a+b)} \right]_0^t = \frac{\sin at - \sin bt}{2(a-b)} + \frac{\sin at + \sin bt}{2(a+b)} \\ &= \frac{a \sin at - b \sin bt}{a^2 - b^2} \end{aligned}$$

Ans.

Example 46. Obtain $L^{-1} \frac{1}{s(s^2+a^2)}$

Solution. $L^{-1} \frac{1}{s} = 1$ and $L^{-1} \frac{1}{(s^2+a^2)} = \frac{\sin at}{a}$

Hence by the convolution theorem

$$\begin{aligned} L^{-1}\left\{1 \cdot \frac{1}{s(s^2+a^2)}\right\} &= \int_0^t 1 \cdot \frac{\sin a(t-x)}{a} dx = \left(\frac{1}{s}\right) \left(\frac{1}{s^2+a^2}\right) \\ L^{-1}\left\{\frac{1}{s(s^2+a^2)}\right\} &= \int_0^t 1 \cdot \frac{\sin a(t-x)}{a} dx = \left[\frac{-\cos(at-ax)}{-a^2} \right]_0^t = \frac{1}{a^2} [1 - \cos at] \end{aligned}$$

Ans.

Exercise 13.15

Obtain the inverse Laplace transform by convolution.

- $\frac{s^2}{(s^2+a^2)^2}$ **Ans.** $\frac{1}{2} t \cos at + \frac{1}{2a} \sin at$
- $\frac{1}{(s^2+1)^3}$ **Ans.** $\frac{1}{8} \{(3-t^2) \sin t - 3t \cos t\}$
- $\frac{s}{(s^2+a^2)^2}$ **Ans.** $\frac{t \sin at}{2a}$
- $\frac{1}{s^2(s^2-a^2)}$ **Ans.** $\frac{1}{a^3} [-at + \sinh at]$
- $\frac{1}{(s+1)(s^2+1)}$ **Ans.** $\frac{1}{2} (\cos t - \sin t - e^{-t})$

Laplace Transformation

13.30. SOLUTION OF DIFFERENTIAL EQUATIONS BY LAPLACE TRANSFORMS

Ordinary linear differential equations with constant coefficients can be easily solved by the Laplace Transform method, without finding the general solution and the arbitrary constants.

The method will be clear from the following examples:

Example 47. Using Laplace transforms, find the solution of the initial value problem

$$y'' - 4y' + 4y = 64 \sin 2t$$

$$y(0) = 0, \quad y'(0) = 1.$$

Solution. Here, we have $y'' - 4y' + 4y = 64 \sin 2t$... (1)

$$y(0) = 0, \quad y'(0) = 1.$$

Taking Laplace transform of both sides of (1), we have

$$[s^2 \bar{y} - sy(0) - y'(0)] - 4[s\bar{y} - y(0)] + 4\bar{y} = \frac{64 \times 2}{s^2 + 4} \quad \dots (2)$$

On putting the values of $y(0)$ and $y'(0)$ in (2), we get

$$s^2 \bar{y} - 1 - 4s\bar{y} + 4\bar{y} = \frac{128}{s^2 + 4}$$

$$\Rightarrow (s^2 - 4s + 4) \bar{y} = 1 + \frac{128}{s^2 + 4}, \quad \Rightarrow (s - 2)^2 \bar{y} = 1 + \frac{128}{s^2 + 4}$$

$$\Rightarrow \bar{y} = \frac{1}{(s - 2)^2} + \frac{128}{(s - 2)^2 (s^2 + 4)} = \frac{1}{(s - 2)^2} - \frac{8}{s - 2} + \frac{16}{(s - 2)^2} + \frac{8s}{s^2 + 4}$$

$$\Rightarrow y = L^{-1} \left[\frac{1}{(s - 2)^2} - \frac{8}{s - 2} + \frac{16}{(s - 2)^2} + \frac{8s}{s^2 + 4} \right]$$

$$\Rightarrow y = -8e^{2t} + 17te^{2t} + 8 \cos 2t \quad \text{Ans.}$$

Example 48. Using the Laplace transforms, find the solution of the initial value problem

$$y'' + 25y = 10 \cos 5t$$

$$y(0) = 2, \quad y'(0) = 0$$

Solution. Taking Laplace transform of the given differential equation, we get

$$[s^2 \bar{y} - sy(0) - y'(0)] + 25 \bar{y} = 10 \frac{s}{s^2 + 25}$$

$$\Rightarrow s^2 \bar{y} - 2s + 25 \bar{y} = \frac{10s}{s^2 + 25}$$

$$\Rightarrow (s^2 + 25) \bar{y} = 2s + \frac{10s}{s^2 + 25}$$

$$\Rightarrow \bar{y} = \frac{2s}{s^2 + 25} + \frac{10s}{s^2 + 25}$$

$$\Rightarrow y = L^{-1} \left[\frac{2s}{s^2 + 25} + \frac{10s}{(s^2 + 25)} \right] = 2 \cos 5t + L^{-1} \left[\frac{10s}{(s^2 + 25)^2} \right]$$

$$= 2 \cos 5t - L^{-1} \left[\frac{d}{ds} \left(\frac{10}{s^2 + 25} \right) \right]$$

$$= 2 \cos 5t + t \sin 5t \quad \text{Ans.}$$

Example 49. Applying convolution, solve the following initial value problem

$$y'' + y = \sin 3t$$

$$y(0) = 0, \quad y'(0) = 0.$$

Solution. $y'' + y = \sin 3t$

Taking Laplace transform of both the sides, we have

$$[s^2 \bar{y} - sy(0) - y'(0)] + \bar{y} = \frac{3}{s^2 + 9} \quad \dots(1)$$

On putting the values of $y(0), y'(0)$ in (1), we get

$$s^2 \bar{y} + \bar{y} = \frac{3}{s^2 + 9} \Rightarrow (s^2 + 1) \bar{y} = \frac{3}{s^2 + 9}$$

$$\bar{y} = \frac{3}{(s^2 + 1)(s^2 + 9)} = \frac{3}{8} \left[\frac{1}{s^2 + 1} - \frac{1}{s^2 + 9} \right]$$

Taking the inversion transform, we get

$$y = \frac{3}{8} L^{-1} \frac{1}{s^2 + 1} - \frac{3}{8} L^{-1} \frac{1}{s^2 + 9}$$

$$y = \frac{3}{8} \sin t - \frac{3}{8} \times \frac{1}{3} \sin 3t = \frac{3}{8} \sin t - \frac{1}{8} \sin 3t$$

Ans.

Example 50. Solve $[t D^2 + (1 - 2t)D - 2] y = 0$, where $y(0) = 1, y'(0) = 2$.

(R.G.P.V. June, 2002)

Solution. Here, $t D^2 y + (1 - 2t) Dy - 2y = 0 \Rightarrow t y'' + y' - 2t y' - 2y = 0$

Taking Laplace transform of given differential equation, we get

$$L(ty'') + L(y') - 2L(ty') - 2L(y) = 0 \Rightarrow -\frac{d}{ds} L\{y''\} + L\{y'\} + 2\frac{d}{ds} L\{y'\} - 2L(y) = 0$$

$$-\frac{d}{ds} [s^2 \bar{y} - sy(0) - y'(0)] + [s \bar{y} - y(0)] + 2\frac{d}{ds} [s \bar{y} - y(0)] - 2\bar{y} = 0$$

Putting the values of $y(0)$ and $y'(0)$, we get

$$-\frac{d}{ds} (s^2 \bar{y} - s - 2) + (s \bar{y} - 1) + 2\frac{d}{ds} (s \bar{y} - 1) - 2\bar{y} = 0 \quad [y(0) = 1, y'(0) = 2]$$

$$\Rightarrow -\frac{d}{ds} (s^2 \bar{y} - s - 2) + (s \bar{y} - 1) + 2\left[s \frac{d\bar{y}}{ds} + \bar{y}\right] - 2\bar{y} = 0 \Rightarrow -(s^2 - 2s) \frac{d\bar{y}}{ds} - s \bar{y} = 0$$

$$\Rightarrow -\frac{d\bar{y}}{\bar{y}} + \frac{1}{s-2} ds = 0 \quad \text{(Separating the variables)}$$

$$\Rightarrow \int \frac{d\bar{y}}{\bar{y}} + \int \frac{ds}{s-2} = 0 \Rightarrow \log \bar{y} + \log(s-2) = \log C$$

$$\Rightarrow \bar{y}(s-2) = C \Rightarrow \bar{y} = \frac{C}{s-2} \Rightarrow y = CL^{-1} \left\{ \frac{1}{s-2} \right\} \Rightarrow y = C e^{2t} \quad \dots(1)$$

Putting $y(0) = 1$ in (1), we get

$$1 = C e^0 \Rightarrow C = 1$$

Putting $C = 1$ in (1), we get $y = e^{2t}$

This is the required solution.

Ans.

Example 51. Using Laplace transform technique solve the following initial value problem

$$\frac{d^2 y}{dt^2} + 2 \frac{dy}{dt} + 2y = 5 \sin t, \text{ where } y(0) = y'(0) = 0$$

Solution. We have, $y'' + 2y' + 2y = 5 \sin t$

$$y(0) = y'(0) = 0$$

Taking the Laplace Transform of both sides, we have

$$[s^2 \bar{y} - sy(0) - y'(0)] + 2[s \bar{y} - y(0)] + 2\bar{y} = 5 \times \frac{1}{s^2 + 1} \quad \dots(1)$$

Laplace Transformation

On substituting the values of $y(0)$, and $y'(0)$ in (1), we get

$$s^2 \bar{y} + 2s \bar{y} + 2 \bar{y} = \frac{5}{s^2 + 1} \Rightarrow [s^2 + 2s + 2] \bar{y} = \frac{5}{s^2 + 1}$$

$$\Rightarrow \bar{y} = \frac{5}{(s^2 + 2s + 2)(s^2 + 1)}$$

Resolving into partial fractions, $y = \frac{2s + 3}{s^2 + 2s + 2} + \frac{-2s + 1}{s^2 + 1}$

Taking the inverse transform, we get

$$\begin{aligned} y &= \mathcal{L}^{-1} \left[\frac{2s + 3}{s^2 + 2s + 2} \right] + \mathcal{L}^{-1} \left[\frac{-2s + 1}{s^2 + 1} \right] = \mathcal{L}^{-1} \left[\frac{2 \left(\frac{s+1}{2} + \frac{1}{2} \right)}{(s+1)^2 + 1} \right] + \mathcal{L}^{-1} \left[\frac{-2s}{s^2 + 1} \right] + \mathcal{L}^{-1} \left[\frac{1}{s^2 + 1} \right] \\ &= \mathcal{L}^{-1} \left[\frac{2(s+1)}{(s+1)^2 + 1} \right] + \mathcal{L}^{-1} \left[\frac{1}{(s+1)^2 + 1} \right] - 2 \cos t + \sin t \\ &= 2e^{-t} \cos t + e^{-t} \sin t - 2 \cos t + \sin t \quad \text{Ans.} \end{aligned}$$

Example 52. Solve the initial value problem

$$2y'' + 5y' + 2y = e^{-2t}, \quad y(0) = 1, \quad y'(0) = 1,$$

using the Laplace transforms.

Solution. $2y'' + 5y' + 2y = e^{-2t}, \quad y(0) = 1, \quad y'(0) = 1$

Taking the Laplace Transform of both sides, we get

$$2[s^2 \bar{y} - sy(0) - y'(0)] + 5[s \bar{y} - y(0)] + 2\bar{y} = \frac{1}{s+2} \quad \dots(1)$$

On substituting the values of $y(0)$ and $y'(0)$ in (1), we get

$$\begin{aligned} 2[s^2 \bar{y} - s - 1] + 5[s \bar{y} - 1] + 2\bar{y} &= \frac{1}{s+2} \\ [2s^2 + 5s + 2] \bar{y} - 2s - 2 - 5 &= \frac{1}{s+2} \\ \bar{y} &= \frac{1}{(s+2)(2s^2 + 5s + 2)} + \frac{2s + 7}{2s^2 + 5s + 2} = \frac{1 + 2s^2 + 7s + 4s + 14}{(2s^2 + 5s + 2)(s+2)} = \frac{2s^2 + 11s + 15}{(2s+1)(s+2)^2} \\ &= \frac{4/9}{2s+1} - \frac{11/9}{s+2} - \frac{1/3}{(s+2)^2} = \frac{4}{9} \frac{1}{2s+1} - \frac{11}{9} \frac{1}{s+2} - \frac{1}{3} \frac{1}{(s+2)^2} \end{aligned}$$

$$y = \frac{2}{9} e^{-\frac{1}{2}t} - \frac{11}{9} e^{-2t} - \frac{1}{3} t e^{-2t} \quad \text{Ans.}$$

Example 53. Solve $\frac{d^2 y}{dx^2} + 2 \frac{dy}{dx} + 5y = e^{-x} \sin x$ where $y(0) = 0, \quad y'(0) = 1$

Solution. $\frac{d^2 y}{dx^2} + 2 \frac{dy}{dx} + 5y = e^{-x} \sin x$

Taking the Laplace Transform of both the sides, we get

$$\begin{aligned} [s^2 \bar{y} - sy(0) - y'(0)] + 2[s \bar{y} - y(0)] + 5\bar{y} &= \mathcal{L}(e^{-x} \sin x) \\ [s^2 \bar{y} - sy(0) - y'(0)] + 2[s \bar{y} - y(0)] + 5\bar{y} &= \frac{1}{(s+1)^2 + 1} \quad \dots (1) \end{aligned}$$

Laplace Transformation

On substituting the values of $y(0)$ and $y'(0)$ in (1), we get

$$(s^2 \bar{y} - 1) + 2(s \bar{y}) + 5 \bar{y} = \frac{1}{s^2 + 2s + 2}$$

$$(s^2 + 2s + 5) \bar{y} = 1 + \frac{1}{s^2 + 2s + 2} = \frac{s^2 + 2s + 3}{s^2 + 2s + 2}$$

$$\bar{y} = \frac{1}{(s^2 + 2s + 5)(s^2 + 2s + 2)}$$

On resolving the R.H. S. into partial fractions, we get

$$\bar{y} = \frac{2}{3} \frac{1}{s^2 + 2s + 5} + \frac{1}{3} \frac{1}{s^2 + 2s + 2}$$

On inversion, we obtain

$$y = \frac{2}{3} L^{-1} \frac{1}{s^2 + 2s + 5} + \frac{1}{3} L^{-1} \frac{1}{s^2 + 2s + 2}$$

$$\Rightarrow y = \frac{1}{3} L^{-1} \frac{2}{(s+1)^2 + (2)^2} + \frac{1}{3} L^{-1} \frac{1}{(s+1)^2 + (1)^2}$$

$$\Rightarrow y = \frac{1}{3} e^{-x} \sin 2x + \frac{1}{3} e^{-x} \sin x$$

$$\Rightarrow y = \frac{1}{3} e^{-x} (\sin x + \sin 2x)$$

Ans.

Example 54. Using Laplace transforms, find the solution of the initial value problem

$$y'' + 9y = 9u(t-3), \quad y(0) = y'(0) = 0$$

where $u(t-3)$ is the unit step function.

Solution. $y'' + 9y = 9u(t-3)$... (1)

Taking Laplace transform of (1), we have

$$s^2 \bar{y} - sy(0) - y'(0) + 9 \bar{y} = 9 \frac{e^{-3s}}{s} \quad \dots (2)$$

Putting the values of $y(0) = 0$ and $y'(0) = 0$ in (2), we get

$$s^2 \bar{y} + 9 \bar{y} = \frac{9e^{-3s}}{s}$$

$$\Rightarrow (s^2 + 9) \bar{y} = 9 \frac{e^{-3s}}{s}$$

$$\Rightarrow \bar{y} = \frac{9e^{-3s}}{s(s^2 + 9)} \Rightarrow y = L^{-1} \frac{9e^{-3s}}{s(s^2 + 9)}$$

$$\Rightarrow L^{-1} \frac{3}{s^2 + 9} = \sin 3t$$

$$\Rightarrow 3L^{-1} \frac{3}{s(s^2 + 9)} = 3 \int_0^t \sin 3t dt = -[\cos 3t]_0^t = 1 - \cos 3t$$

$$\Rightarrow y = L^{-1} \frac{9e^{-3s}}{s(s^2 + 9)}$$

$$\Rightarrow y = [1 - \cos 3(t-3)] u(t-3)$$

Ans.

Laplace Transformation

Example 55. A resistance R in series with inductance L is connected with e.m.f. $E(t)$.
The current i is given by

$$L \frac{di}{dt} + Ri = E(t)$$

If the switch is connected at $t = 0$ and disconnected at $t = a$, find the current i in terms of t .
(UP., II Semester; Summer 2001)

Solution. Conditions under which current i flows are $i = 0$ at $t = 0$,

$$E(t) = \begin{cases} E, & 0 < t < a \\ 0, & t > a \end{cases}$$

Given equation is $L \frac{di}{dt} + Ri = E(t)$... (1)

Taking Laplace transform of (1), we get

$$L [si - i(0)] + R\bar{i} = \int_0^{\infty} e^{-st} E(t) dt$$

$$Ls\bar{i} + R\bar{i} = \int_0^{\infty} e^{-st} E(t) dt \quad [i(0) = 0]$$

$$(Ls + R)\bar{i} = \int_0^a e^{-st} E dt = \int_0^a e^{-st} E dt + \int_a^{\infty} e^{-st} E dt$$

$$= E \left[\frac{e^{-st}}{-s} \right]_0^a + 0 = \frac{E}{s} [1 - e^{-as}] = \frac{E}{s} - \frac{E}{s} e^{-as}$$

$$\bar{i} = \frac{E}{s(Ls + R)} - \frac{Ee^{-as}}{s(Ls + R)}$$

On inversion, we obtain $i = L^{-1} \left[\frac{E}{s(Ls + R)} - L^{-1} \left[\frac{Ee^{-as}}{s(Ls + R)} \right] \right]$... (2)

Now we have to find the value of $L^{-1} \left[\frac{E}{s(Ls + R)} \right]$ and $L^{-1} \left[\frac{Ee^{-as}}{s(Ls + R)} \right]$

$$L^{-1} \left[\frac{E}{s(Ls + R)} \right] = \frac{E}{L} L^{-1} \left[\frac{E/R}{s \left(s + \frac{R}{L} \right)} \right] \quad \text{(Resolving into partial fractions)}$$

$$= \frac{E}{L} L^{-1} \left[\frac{1}{s} - \frac{1}{s + \frac{R}{L}} \right] = \frac{E}{R} \left[1 - e^{-\frac{R}{L}t} \right]$$

and $L^{-1} \left[\frac{Ee^{-as}}{s(Ls + R)} \right] = \frac{E}{R} \left[1 - e^{-\frac{R}{L}(t-a)} \right] u(t-a)$

[By the second shifting theorem]

On substituting the values of the inverse transforms in (2) we get

$$i = \frac{E}{R} \left[1 - e^{-\frac{R}{L}t} \right] - \frac{E}{R} \left[1 - e^{-\frac{R}{L}(t-a)} \right] u(t-a)$$

Hence $i = \frac{E}{R} \left[1 - e^{-\frac{R}{L}t} \right]$ for $0 < t < a$, $[u(t-a) = 0]$

Laplace Transformation

$$i = \frac{E}{R} \left[1 - e^{-\frac{R}{L}t} \right] - \frac{E}{R} \left[1 - e^{-\frac{R}{L}(t-a)} \right] \quad \left[\begin{array}{l} \text{for } t > a \\ u(t-a) = 1 \end{array} \right]$$

$$= \frac{E}{R} \left[e^{-\frac{R}{L}(t-a)} - e^{-\frac{R}{L}t} \right] = \frac{E}{R} e^{-\frac{R}{L}t} \left\{ e^{\frac{Ra}{L}} - 1 \right\}$$

Ans.

Example 56. Using the Laplace transform, find the current $i(t)$ in the LC - circuit. Assuming $L = 1$ henry, $C = 1$ farad, zero initial current and charge on the capacitor, and $v(t) = t$, when $0 < t < 1$ = 0 otherwise.

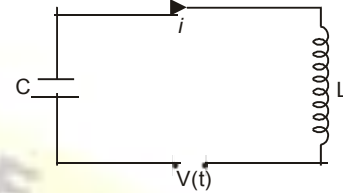

Solution. The differential equation for L and C circuit is given by $L \frac{d^2q}{dt^2} + \frac{q}{C} = E$... (1)

Putting $L = 1, C = 1, E = v(t)$ in (1), we get $\frac{d^2q}{dt^2} + q = v(t)$... (2)

Taking Laplace Transform of (2), we have

$$s^2 q - sq(0) - q'(0) + q = \int_0^\infty v(t) e^{-st} dt$$

Substituting $q(0) = 0$, and $q'(0) = 0$, we get

$$s^2 q + q = \int_0^1 t e^{-st} dt + \int_1^\infty 0 e^{-st} dt$$

$$\Rightarrow (s^2 + 1) q = \left[t \frac{e^{-st}}{-s} \right]_0^1 - \int_0^1 \frac{e^{-st}}{-s} dt = \frac{e^{-s}}{-s} - \left[\frac{e^{-st}}{-s^2} \right]_0^1 = -\frac{e^{-s}}{s} - \frac{e^{-s}}{s^2} + \frac{1}{s^2}$$

$$\Rightarrow q = \frac{-e^{-s}}{s^2 + 1} - \frac{e^{-s}}{s^2(s^2 + 1)} + \frac{1}{s^2(s^2 + 1)}$$

Taking Inverse Laplace Transform, we get

$$q = L^{-1} \frac{-e^{-s}}{s(s^2 + 1)} - L^{-1} \frac{e^{-s}}{s^2(s^2 + 1)} + L^{-1} \frac{1}{s^2(s^2 + 1)} \quad \dots (3)$$

We know that

$$L^{-1} \left[\frac{e^{-as} F(s)}{s} \right] = \int_t^{\infty} f(t-a) u(t-a) dt$$

$$L^{-1} \left[\frac{e^{-s}}{s(s^2 + 1)} \right] = \int_0^t \sin t dt = [-\cos t]_0^t = 1 - \cos t \quad \dots (4)$$

$$L^{-1} \left[\frac{1}{s^2(s^2 + 1)} \right] = \int_0^t (1 - \cos t) dt = t - \sin t \quad \dots (5)$$

In view of this, we have

$$L^{-1} \left[\frac{-e^{-s}}{s(s^2 + 1)} \right] = -[1 - \cos(t-1)] u(t-1) \quad \text{[From (4)]}$$

$$L^{-1} \left[\frac{e^{-s}}{s^2(s^2 + 1)} \right] = [(t-1) - \sin(t-1)] u(t-1) \quad \text{[From (5)]}$$

Putting the above values in (3), we get

$$q = -[1 - \cos(t-1)] u(t-1) - [(t-1) - \sin(t-1)] u(t-1) + t - \sin t \quad \text{Ans.}$$

Laplace Transformation

EXERCISE 13.16

Solve the following differential equations:

1. $\frac{d^2y}{dx^2} + y = 0$, where $y = 1$ and $\frac{dy}{dx} = 1$ at $x = 0$. **Ans.** $y = \cos x - \sin x$
2. $\frac{d^2y}{dx^2} - 4y = 0$, where $y = 0$ and $\frac{dy}{dx} = -6$ at $x = 0$. **Ans.** $y = -\frac{3}{2}e^{2x} + \frac{3}{2}e^{-2x}$
3. $\frac{d^2y}{dx^2} + y = 0$, where $y = 1$, $\frac{dy}{dx} = 1$ at $x = 0$. **Ans.** $y = \sin x + \cos x$
4. $\frac{d^2y}{dx^2} + 2\frac{dy}{dx} + 5y = 0$, where $y = 2$, $\frac{dy}{dx} = -4$ at $x = 0$. **Ans.** $y = e^{-x}(2\cos 2x - \sin 2x)$
5. $\frac{d^3y}{dx^3} + 2\frac{d^2y}{dx^2} - \frac{dy}{dx} - 2y = 0$, given $y = \frac{dy}{dx} = 0$, $\frac{d^2y}{dx^2} = 6$ at $x = 0$. **Ans.** $y = e^x - 3e^{-x} + 2e^{-2x}$
6. $\frac{d^2y}{dx^2} + y = 3\cos 2x$, where $y = \frac{dy}{dx} = 0$ at $x = 0$. **Ans.** $y = \cos x - \cos 2x$
7. $\frac{d^2y}{dx^2} + \frac{dy}{dx} - 2y = 1 - 2x$, given $y = 0$, $\frac{dy}{dx} = 4$ at $x = 0$. **Ans.** $y = e^x - e^{-2x} + x$
8. $\frac{d^2y}{dx^2} - 3\frac{dy}{dx} + 2y = 4e^{2x}$, given $y = -3$, and $\frac{dy}{dx} = 5$ at $x = 0$. **Ans.** $y = -7e^x + 4e^{2x} + 4xe^{2x}$
9. $\frac{d^2y}{dx^2} - 3\frac{dy}{dx} + 2y = 4x + e^{2x}$, where $y = 1$, $\frac{dy}{dx} = -1$ at $x = 0$. **Ans.** $y = 3 + 2x + \frac{1}{5}e^{2x} - 2e^{-x} - \frac{1}{2}e^{-2x}$
10. $\frac{d^3y}{dx^3} + 2\frac{d^2y}{dx^2} - \frac{dy}{dx} - 2y = 0$, where $y = 1$, $\frac{dy}{dx} = 2$, $\frac{d^2y}{dx^2} = 2$ at $x = 0$. **Ans.** $\frac{1}{3}e^{-x} - e^{-2x} + \frac{1}{3}e^{-3x}$
11. $(D^2 - D - 2)x = 20 \sin 2t$, $x_0 = -1$, $x_1 = 2$. **Ans.** $x = 2e^{2t} - 4e^{-t} + \cos 2t - 3 \sin 2t$
12. $(D^3 + D^2)x = 6t^2 + 4$, $x(0) = 0$, $x'(0) = 2$, $x''(0) = 0$. **Ans.** $x = \frac{1}{2}t^4 - 2t^3 + 8t^2 - 16t + 16 - 16e^{-t}$
13. $\frac{d^2x}{dt^2} - 2\frac{dx}{dt} + x = e^t$, where $x(0) = 2$, $\frac{dx}{dt} = -1$ at $t = 0$. **Ans.** $x = 2e^t - 3te^t + \frac{1}{2}t^2e^t$
14. $(D^2 + n^2)x = a \sin(nt + \alpha)$ where $x = Dx = 0$ at $t = 0$.
Ans. $x = a n \cos \alpha (\sin nt - nt \cos nt) + \frac{a \sin 2\alpha}{2n} (t \sin nt)$
15. $y'' + 2y' + y = t e^{-t}$ if $y(0) = 1$, $y'(0) = -2$. **Ans.** $y = \left(1 - t + \frac{t^2}{6}\right) e^{-t}$
16. $\frac{d^2y}{dx^2} + y = x \cos 2x$, where $y = \frac{dy}{dx} = 0$ at $x = 0$. **Ans.** $y = \frac{1}{9} \sin 2x - \frac{1}{9} \sin x - \frac{1}{3} \cos 2x$
17. $\frac{d^3y}{dx^3} - 3\frac{d^2y}{dx^2} + 3\frac{dy}{dx} - y = x^2 e^{2x}$, where $y = 1$, $\frac{dy}{dx} = 0$, $\frac{d^2y}{dx^2} = -2$ at $x = 0$.
Ans. $y = e^{2x}(x^2 - 6x + 12) - e^x(15x^2 + 7x + 11)$
18. $y'' + 4y' + 3y = t$, $t > 0$; given that $y(0) = 0$ and $y'(0) = 1$. **Ans.** $y = -\frac{4}{9} + \frac{t}{6} + e^{-t} - \frac{5}{9}e^{-3t}$

Laplace Transformation

19. $y'' + 2y = r(t)$, $y(0) = 0$, $y'(0) = 0$ where $r(t) = \begin{cases} 0, & t \geq 1 \\ 1, & 0 \leq t < 1 \end{cases}$ **Ans.** $y = \frac{1}{2} - \frac{1}{2} \cos \sqrt{2}t$.

20. $\frac{d^2y}{dt^2} + 4y = u(t-2)$, where u is unit step function

$y(0) = 0$ and $y'(0) = 1$

Ans. $y = \frac{1}{2} \sin 2t$ for $t < 2$

21. $\frac{d^2y}{dx^2} + y = u(t-\pi) - u(t-2\pi)$, $y(0) = 0$, $y'(0) = 0$

Ans. $y = (1 + \cos t)u(t-\pi) - (1 - \cos t)u(t-2\pi)$

22. A condenser of capacity C is charged to potential E and discharged at $t = 0$ through an inductance L and resistance R . The charge q at time t is governed by the differential equation

$$L \frac{d^2q}{dt^2} + R \frac{dq}{dt} + \frac{q}{C} = E$$

Using Laplace transforms, show that the charge q is given by

$$q = \frac{CE}{n} e^{-\mu t} [\mu \sin nt + n \cos nt] \text{ where } \mu = \frac{R}{2L} \text{ and } \eta^2 = \frac{1}{LC} - \frac{R^2}{4L^2}$$

SOLUTION OF SIMULTANEOUS DIFFERENTIAL EQUATIONS BY LAPLACE TRANSFORMS

Simultaneous differential equations can also be solved by Laplace Transform method.

Example 57. Solve $\frac{dx}{dt} + y = 0$ and $\frac{dy}{dt} - x = 0$ under the condition $x(0) = 1$, $y(0) = 0$

Solution. $x' + y = 0$... (1)

$y' - x = 0$... (2)

Taking the Laplace transform of (1) and (2) we get

$[s\bar{x} - x(0)] + \bar{y} = 0$... (3)

$[s\bar{y} - y(0)] - \bar{x} = 0$... (4)

On substituting the values of $x(0)$ and $y(0)$ in (3) and (4), we get

$s\bar{x} - 1 + \bar{y} = 0$... (5)

$s\bar{y} - \bar{x} = 0$... (6)

Solving (5) and (6) for \bar{x} and \bar{y} we get

$$\bar{x} = \frac{s}{s^2 + 1}, \bar{y} = \frac{1}{s^2 + 1}$$

On inversion, we obtain

$$x = L^{-1} \left(\frac{s}{s^2 + 1} \right), y = L^{-1} \left(\frac{1}{s^2 + 1} \right)$$

$x = \cos t, y = \sin t$

Ans.

Example 58. Using Laplace transforms, solve the differential equations

$(D+1)y_1 + (D-1)y_2 = e^{-t}$

$(D+2)y_1 + (D+1)y_2 = e^t$

where $D = d/dt$ and $y_1(0) = 1$, $y_2(0) = 0$

Solution. $(D+1)y_1 + (D-1)y_2 = e^{-t}$... (1)

$(D+2)y_1 + (D+1)y_2 = e^t$... (2)

Multiply (1) by $(D+1)$ and (2) by $(D-1)$ we get

$(D+1)^2 y_1 + (D^2-1)y_2 = (D+1)e^{-t}$... (3)

Laplace Transformation

$$(D - 1)(D + 2)y_1 + (D^2 - 1)y_2 = (D - 1)e^t \quad \dots(4)$$

Subtracting (4) from (3) we get

$$(D^2 + 2D + 1 - D^2 - D + 2)y_1 = (-e^{-t} + e^t) - (e^t - e^t)$$

$$\Rightarrow (D + 3)y_1 = 0 \Rightarrow Dy_1 + 3y_1 = 0$$

Taking Laplace transform we have $s\bar{y}_1 - y_1(0) + 3\bar{y}_1 = 0$

$$(s+3)\bar{y}_1 = 1 \Rightarrow \bar{y}_1 = \frac{1}{s+3} \Rightarrow y_1 = e^{-3t}$$

Putting the value of y_1 in (1) we get

$$(D+1)e^{-3t} + (D-1)y_2 = e^{-t}$$

$$-3e^{-3t} + (D-1)y_2 = e^{-t} \Rightarrow Dy_2 - y_2 = e^{-t} + 2e^{-3t}$$

Taking Laplace transform, we get

$$s\bar{y}_2 - y_2(0) - \bar{y}_2 = \frac{1}{s+1} + \frac{2}{s+3}$$

$$(s-1)\bar{y}_2 = \frac{1}{s+1} + \frac{2}{s+3}$$

$$\bar{y}_2 = \frac{1}{s^2-1} + \frac{2}{s^2+2s-3}$$

$$y_2 = L^{-1} \left[\frac{1}{s^2-1} + \frac{2}{s^2+2s-3} \right]$$

$$y_2 = \sinh t + e^{-t} \sinh 2t$$

$$y_1 = e^{-3t} \text{ and } y_2 = \sinh t + e^{-t} \sinh 2t$$

Ans.

Example 59. Solve $\frac{dx}{dt} - y = e^t$, $\frac{dy}{dt} + x = \sin t$

given $x(0) = 1$, $y(0) = 0$

Solution. $x' - y = e^t$... (1)

$y' + x = \sin t$... (2)

Taking the Laplace Transform of (1) and (2), we get

$$[s\bar{x} - x(0)] - \bar{y} = \frac{1}{s-1} \quad \dots (3)$$

$$[s\bar{y} - y(0)] + \bar{x} = \frac{1}{s^2+1} \quad \dots (4)$$

On substituting the values of $x(0)$ and $y(0)$ in (3) and (4), we get

$$s\bar{x} - 1 - \bar{y} = \frac{1}{s-1} \quad \dots (5)$$

$$s\bar{y} + x = \frac{1}{s^2+1} \quad \dots (6)$$

On solving (5) and (6), we get

$$\bar{x} = \frac{s^4 + s^2 + s - 1}{(s-1)(s^2+1)^2} = \frac{1}{2} \frac{1}{s-1} + \frac{1}{2} \frac{s+1}{s^2+1} + \frac{1}{(s^2+1)^2} \quad \dots (7)$$

$$\bar{y} = \frac{-s^3 + s^2 - 2s}{(s-1)(s^2+1)^2} = -\frac{1}{2} \frac{1}{s-1} + \frac{1}{2} \frac{s-1}{s^2+1} + \frac{s}{(s^2+1)^2} \quad \dots (8)$$

On inversion of (7), we obtain

$$x = \frac{1}{2} L^{-1} \frac{1}{s-1} + \frac{1}{2} L^{-1} \frac{s}{s^2+1} + \frac{1}{2} L^{-1} \frac{1}{s^2+1} + L^{-1} \frac{1}{(s^2+1)^2}$$

Laplace Transformation

$$= \frac{1}{2}e^t + \frac{1}{2}\cos t + \frac{1}{2}\sin t + \frac{1}{2}(\sin t - t \cos t) = \frac{1}{2}[e^t + \cos t + 2\sin t - t \cos t]$$

On inversion of (8), we get

$$y = -\frac{1}{2}L^{-1}\frac{1}{s-1} + \frac{1}{2}L^{-1}\frac{s}{s^2+1} - \frac{1}{2}L^{-1}\frac{1}{s^2+1} + L^{-1}\frac{s}{(s^2+1)^2}$$

$$\Rightarrow y = -\frac{1}{2}e^t + \frac{1}{2}\cos t - \frac{1}{2}\sin t + \frac{1}{2}t \sin t$$

$$\Rightarrow y = \frac{1}{2}[-e^t - \sin t + \cos t + t \sin t]$$

Ans.

Example 60. Using the Laplace transforms, solve the initial value problem

$$y_1'' = y_1 + 3y_2$$

$$y_2'' = 4y_1 - 4e^t$$

$$y_1(0) = 2, y_1'(0) = 3, y_2(0) = 1, y_2'(0) = 2$$

Solution.

$$y_1'' = y_1 + 3y_2 \quad \dots (1)$$

$$y_2'' = 4y_1 - 4e^t \quad \dots (2)$$

Taking the Laplace transform of (1) and (2), we get

$$s^2\bar{y}_1 - sy_1(0) - y_1'(0) = \bar{y}_1 + 3\bar{y}_2 \quad \dots (3)$$

$$s^2\bar{y}_2 - sy_2(0) - y_2'(0) = 4\bar{y}_1 - \frac{4}{s-1} \quad \dots (4)$$

Putting the values of $y_1(0)$, $y_1'(0)$, $y_2(0)$, $y_2'(0)$ in (3) and (4), we get

$$s^2\bar{y}_1 - 2s - 3 = \bar{y}_1 + 3\bar{y}_2 \Rightarrow (s^2 - 1)\bar{y}_1 - 3\bar{y}_2 = 2s + 3 \quad \dots (5)$$

$$\Rightarrow s^2\bar{y}_2 - s - 2 = 4\bar{y}_1 - \frac{4}{s-1} \Rightarrow 4\bar{y}_1 - s\bar{y}_2 = \frac{4}{s-1} - s - 2 \quad \dots (6)$$

On solving (5) and (6), we get

$$\bar{y}_1 = \frac{(2s-3)(s^2+3)(s+2)}{(s-1)(s^2+3)(s^2-4)} = \frac{2s-3}{(s-1)(s-2)} = \frac{1}{s-1} + \frac{1}{s-2}$$

$$y_1 = e^t + e^{2t}$$

$$\bar{y}_2 = \frac{(s+2)(s^2+3)}{(s^2+3)(s^2-4)} = \frac{1}{s-2} \Rightarrow y_2 = e^{2t}$$

Ans.

Exercise 13.17

Solve the following :

1. $\frac{dx}{dt} + 4y = 0, \frac{dy}{dt} - 9x = 0$ Given $x = 2$ and $y = 1$ at $t = 0$.

Ans. $x = -\frac{2}{3}\sin 6t + 2\cos 6t, y = \cos 6t + 3\sin 6t$

2. $4\frac{dy}{dt} + \frac{dx}{dt} + 3y = 0, \frac{3dx}{dt} + 2x + \frac{dy}{dt} = 1$

under the condition $x = y = 0$ at $t = 0$. **Ans.** $x = \frac{1}{2} - \frac{1}{5}e^{-t} - \frac{3}{10}e^{-\frac{6}{11}t}, y = \frac{1}{5}e^{-t} - \frac{1}{5}e^{-\frac{6}{11}t}$

3. $\frac{dx}{dt} + 5x - 2y = t, \frac{dy}{dt} + 2x + y = 0$ being given $x = y = 0$ when $t = 0$.

Ans. $x = -\frac{1}{27}(1+6t)e^{-3t} + \frac{1}{27}(1+3t), y = -\frac{2}{27}(2+3t)e^{-3t} - \frac{2t}{9} + \frac{4}{27}$

Laplace Transformation

4. $\frac{dx}{dt} + y = \sin t, \frac{dy}{dt} + x = \cos t$

given that $x = 2$, and $y = 0$ when $t = 0$.

Ans. $x = e^t + e^{-t}, y = e^{-t} - e^t + \sin t$

5. $(D - 1)x - 2y = t, -2x + (D - 1)y = t, t > 0$

where $D = d/dt$ and $x(0) = 2, y(0) = 4$

6. The small oscillations of a certain system with two degrees of freedom are given by the equations

$$D^2x + 3x - 2y = 0, D^2y + 3y - 2x = 0$$

If $x = 0, y = 0, Dx = 3, Dy = 2$ when $t = 0$.

Ans. $x = -\frac{11}{4}\sin t + \frac{1}{12}\sin 3t, y = \frac{11}{4}\sin t - \frac{1}{4}\sin 3t$

7. $3\frac{dx}{dt} + 3\frac{dy}{dt} + 5x = 25\cos t, 2\frac{dx}{dt} - 3\frac{dy}{dt} = 5\sin t$ with $x(0) = 2, y(0) = 3$.

Ans. $x = 2\cos t + 3\sin t, y = 3\cos t + 2\sin t$

METHODS TO FIND OUT RESIDUES ON PAGE 590 (Art. 7.58)**INVERSION FORMULA FOR THE LAPLACE TRANSFORM**

$f(x)$ = sum of the residues of $e^{sx} F(s)$ at the poles of $F(s)$.

Proof. The Laplace Transform of $f(x)$ is defined by

$$F(s) = \int_0^{\infty} e^{-st} \cdot f(t) dt$$

Multiplying by e^{sx}

$$e^{sx} F(s) = e^{sx} \int_0^{\infty} e^{-st} \cdot f(t) dt$$

Integrating w.r.t. 's' between the limits $a + ir$ and $a - ir$, we have

$$\int_{a-ir}^{a+ir} e^{sx} F(s) ds = \int_{a-ir}^{a+ir} e^{sx} ds \int_0^{\infty} e^{-st} \cdot f(t) dt$$

Putting $s = a - ip, ds = -idp = -i \int_r^{-r} e^{x(a-ip)} \int_0^{\infty} f(t) e^{-(a-ip)t} dt dp$

$$= ie^{ax} \int_{-r}^r e^{-ipx} dp \int_0^{\infty} f(t) e^{-at} \cdot e^{ipt} dt. \quad \dots(1)$$

Let us now define $\phi(x)$ as
$$\phi(x) = \begin{cases} e^{-ax} f(x) & \text{when } x \geq 0 \\ 0 & \text{when } x < 0 \end{cases}$$

The Fourier complex integral of $\phi(x)$ is

$$\phi(x) = \frac{1}{2\pi} \int_{-\infty}^{\infty} e^{ipx} \int_{-\infty}^{\infty} \phi(t) e^{ipt} dt dp$$

$$\Rightarrow e^{-ax} f(x) = \frac{1}{2\pi} \int_{-\infty}^{\infty} e^{-ipx} \int_0^{\infty} [e^{-at} f(t)] e^{ipt} dt dp \quad \dots(2)$$

In the limiting case when $r \rightarrow \infty$, (1) becomes

$$\int_{a-i\infty}^{a+i\infty} e^{sx} F(s) ds = ie^{ax} \int_{-\infty}^{\infty} e^{-ipx} dp \int_0^{\infty} f(t) e^{-at} \cdot e^{ipt} dt \quad \dots(3)$$

Substituting the value of the integral from (2) in (3), we get

$$\int_{a-i\infty}^{a+i\infty} e^{sx} F(s) ds = ie^{ax} [2\pi e^{-ax} f(x)] = 2\pi f(x)$$

Laplace Transformation

$$\Rightarrow f(x) = \frac{1}{2\pi i} \int_{a-i\infty}^{a+i\infty} e^{sx} F(s) ds \quad \dots(4)$$

Equation (4) is called the inversion formula for the Laplace transform. To obtain $f(x)$, the integration is performed along a line AB parallel to imaginary axis in the complex plane such that all the singularities of $F(s)$ lie to its left. The contour c includes the line AB and the semicircle c' (i.e. BDA).

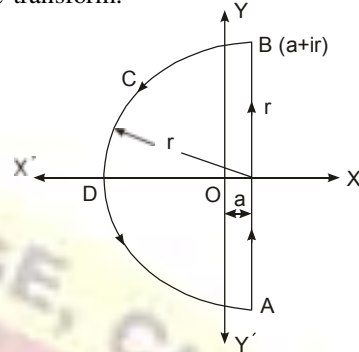

From (4)

$$\begin{aligned} f(x) &= \frac{1}{2\pi i} \int_{AB} e^{sx} F(s) ds \\ &= \frac{1}{2\pi i} \int_c e^{sx} F(s) ds \\ &\quad - \frac{1}{2\pi i} \int_{c'} e^{sx} F(s) ds \end{aligned}$$

The integral over c' tends to zero as $r \rightarrow \infty$. Therefore,

$$f(x) = \lim_{r \rightarrow \infty} \frac{1}{2\pi i} \int_c e^{sx} F(s) ds$$

$f(x)$ = sum of the residue of $e^{sx} F(s)$ at the poles of $F(s)$.

Note. Methods for finding the residue: See article 7.58 on page 590.

Example 61. Obtain the inverse Laplace transform of $\frac{s+1}{s^2+2s}$

Solution. Let $F(s) = \frac{s+1}{s^2+2s}$ (1)

$$L^{-1} \left[\frac{s+1}{s^2+2s} \right] = \text{Sum of the residues of } e^{st} \cdot \frac{s+1}{s^2+2s} \text{ at the poles..... (2)}$$

The poles of (1) are determined by equating the denominator to zero, i.e.

$$s^2 + 2s = 0 \text{ or } s(s+2) = 0 \quad \text{i.e. } s = 0, -2$$

There are two simple poles at $s = 0$ and $s = -2$.

$$\text{Residue of } e^{st} \cdot F(s) \text{ (at } s = 0) = \lim_{s \rightarrow 0} \left[(s-0) \frac{e^{st}(s+1)}{s^2+2s} \right] = \lim_{s \rightarrow 0} \left[\frac{e^{st}(s+1)}{(s+2)} \right] = \frac{1}{2}$$

$$\begin{aligned} \text{Residue of } e^{st} \cdot F(s) \text{ (at } s = -2) &= \lim_{s \rightarrow -2} \left[(s+2) \frac{e^{st}(s+1)}{s(s+2)} \right] \\ &= \lim_{s \rightarrow -2} \left[\frac{e^{st}(s+1)}{s} \right] = \frac{e^{-2t}(-2+1)}{-2} = \frac{e^{-2t}}{2} \end{aligned}$$

$$\text{Sum of the residue [at } s = 0 \text{ and } s = -2] = \frac{1}{2} + \frac{e^{-2t}}{2}$$

Putting the value of residues in (2), we get

$$L^{-1} \left[\frac{s+1}{s^2+2s} \right] = \frac{1}{2} + \frac{e^{-2t}}{2}$$

Ans.

Laplace Transformation

Example 62. Find the inverse Laplace transform of $\frac{1}{(s+1)(s^2+1)}$.

Solution. Let $F(s) = \frac{1}{(s+1)(s^2+1)}$... (1)

$$L^{-1} \left[\frac{1}{(s+1)(s^2+1)} \right] = \text{sum of residues of } e^{st} F(s) \text{ at the poles. (2)}$$

The poles of (1) are obtained by equating the denominator equal to zero, i.e.,

$$(s+1)(s^2+1) = 0 \Rightarrow s = -1, +i, -i$$

There are three poles of $F(s)$ at $s = -1, s = +i$ and $s = -i$.

Residue of $e^{st} \cdot F(s)$ (at $s = -1$) $= \lim_{s \rightarrow -1} (s+1) \frac{e^{st}}{(s+1)(s^2+1)} = \lim_{s \rightarrow -1} \frac{e^{-t}}{s^2+1} = \frac{e^{-t}}{2}$

Residue of $e^{st} \cdot F(s)$ (at $s = i$) $= \lim_{s \rightarrow i} (s-i) \frac{e^{st}}{(s+1)(s^2+1)}$
 $= \lim_{s \rightarrow i} \frac{e^{st}}{(s+1)(s+i)} = \frac{e^{it}}{(i+1)(2i)} = -i \frac{e^{it}}{2(i+1)(1-i)} = -\frac{e^{it}}{4}(1+i)$

Residue of $e^{st} \cdot F(s)$ (at $s = -i$) $= \lim_{s \rightarrow -i} (s+i) \frac{e^{st}}{(s+1)(s^2+1)}$
 $= \lim_{s \rightarrow -i} \frac{e^{st}}{(s+1)(s-i)} = \frac{e^{-it}}{(-i+1)(-2i)} = \frac{e^{-it}(i-1)}{4}$

Substituting the values of the residues in (2), we get

$$L^{-1} \left[\frac{1}{(s+1)(s^2+1)} \right] = \frac{e^{-t}}{2} - \frac{e^{it}(1+i)}{4} + \frac{e^{-it}(i-1)}{4}$$

$$= \frac{e^{-t}}{2} + \frac{-e^{-it} - ie^{it} + ie^{-it} - e^{-it}}{4} = \frac{e^{-t}}{2} - \frac{e^{it} + e^{-it}}{4} - \frac{i}{2} \frac{e^{it} - e^{-it}}{2}$$

$$= \frac{e^{-t}}{2} - \frac{1}{2} \cos t + \frac{1}{2} \sin t$$

Ans.

Example 63. Find the inverse Laplace transform of $\frac{s^2-1}{(s^2+1)^2}$.

Solution. Let $F(s) = \frac{s^2-1}{(s^2+1)^2}$... (1)

$$L^{-1} \left[\frac{s^2-1}{(s^2+1)^2} \right] = \text{sum of residues of } e^{st} \cdot F(s) \text{ at the poles} \dots (2)$$

The poles of (1) are obtained by equating denominator to zero.

$$(s^2+1)^2 = 0 \text{ i.e. } s = i, -i$$

There are two poles of second order at $s = i$ and $s = -i$

Residue of $e^{st} \cdot F(s)$ (at $s = i$) $= \frac{d}{ds} \left[\frac{(s-i)^2 e^{st} (s^2-1)}{(s^2+1)^2} \right]_{s=i} = \frac{d}{ds} \left[\frac{e^{st} (s^2-1)}{(s+i)^2} \right]_{s=i}$
 $= \left[\frac{(s+i)^2 [e^{st} t (s^2-1) + e^{st} 2s] - 2(s+i) e^{st} (s^2-1)}{(s+i)^4} \right]_{s=i}$

Laplace Transformation

$$= \left[\frac{(s+i) \left[e^{st} \cdot t(s^2-1) + e^{st} \cdot 2s \right] + e^{st}(s^2-1)}{(s+i)^3} \right]_{s=i}$$

$$= \frac{2i \left[e^{it} \cdot t(-2) + e^{it} \cdot 2i \right] - 2e^{it}(-2)}{(2i)^3} = \frac{-4ite^{it}}{-8i} = \frac{te^{it}}{2}$$

Residue of $e^{st} \cdot F(s)$ (at $s = -i$) = $\frac{d}{ds} \left[\frac{(s+i)^2 \left[e^{st} \cdot t(s^2-1) + 2s e^{st} \right]}{(s^2+1)^2} \right]_{s=-i}$ = $\frac{d}{ds} \left[\frac{e^{st} \cdot (s^2-1)}{(s-i)^2} \right]_{s=-i}$

$$= \left[\frac{(s-i)^2 \left[e^{st} \cdot t(s^2-1) + 2s e^{st} \right] - e^{st}(s^2-1)2(s-i)}{(s-i)^4} \right]_{s=-i}$$

$$= \left[\frac{(s-i) \left[e^{st} \cdot (s^2-1) + 2s e^{st} \right] - e^{st}(s^2-1)2}{(s-i)^3} \right]_{s=-i}$$

$$= \frac{-2i \left[e^{-it} \cdot t(-2) - 2ie^{-it} - e^{-it}(-2)2 \right] - e^{-it}(-2)2}{(-2i)^3} = \frac{4ite^{-it}}{(-2i)^3} = \frac{t \cdot e^{-it}}{2}$$

Sum of the residues at ($s = i$ and $s = -i$)

$$= \frac{t \cdot e^{it}}{2} + \frac{t \cdot e^{-it}}{2} = t \frac{e^{it} + e^{-it}}{2} = t \cos t. \quad \dots(3)$$

Putting the value of sum of residues from (3) in (2), we get

$$\mathcal{L}^{-1} \left[\frac{s^2-1}{(s^2+1)^2} \right] = t \cos t \quad \text{Ans.}$$

Example 64. Obtain the inverse Laplace Transform of $\frac{e^{-hs}}{s}$.

Solution. Let

$$F(s) = \frac{e^{-hs}}{s} \quad \dots(1)$$

$$\mathcal{L}^{-1} \left(\frac{e^{-bs}}{s} \right) = \frac{1}{2\pi i} \int_{a-i\infty}^{a+i\infty} e^{st} \cdot \frac{e^{-bs}}{s} ds \quad \dots(2)$$

The simple pole of $F(s)$ is at $s = 0$. Let us have a contour $ABCDEF$ excluding the pole at $x = 0$. The contour encloses no singularity, therefore, by Cauchy theorem.

$$\int_{ABCDEF} e^{st} \cdot F(s) ds = 0$$

$$\Rightarrow \int_{AB} e^{st} \cdot F(s) ds + \int_{BC} e^{st} \cdot F(s) ds + \int_{CD} e^{st} \cdot F(s) ds + \int_{DE} e^{st} \cdot F(s) ds + \int_{EF} e^{st} \cdot F(s) ds + \int_{FA} e^{st} \cdot F(s) ds = 0 \quad \dots(3)$$

Let $OC = \rho$, $OD = \epsilon$, then along CD , $s = Re^{i\pi}$

$$\int_{CD} e^{sx} \cdot F(s) ds = \int_{\rho}^{\epsilon} e^{-xR} \frac{e^{-ib\sqrt{R}}}{R} dR$$

$$\int_{EF} e^{sx} \cdot F(s) ds = \int_{\epsilon}^{\rho} e^{-xR} \frac{e^{-ib\sqrt{R}}}{R} dR \quad (S = Re^{-i\pi} \text{ along } EF)$$

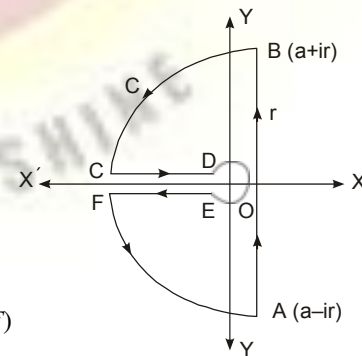

Laplace Transformation

$$\int_{DE} e^{sx} \cdot F(s) ds = \int_{-\pi}^{\pi} \frac{1}{\epsilon e^{i\theta}} (\epsilon e^{i\theta} id\theta) = -2\pi i$$

$$\left\{ \begin{array}{l} \int_{\pi}^{\pi} \epsilon e^{i\theta} \\ e^{-b\sqrt{x}} = 1 \end{array} \right. \text{ along DE}$$

$$\int_{BC} e^{sx} \cdot F(s) ds = 0, \int_{FA} e^{sx} \cdot F(s) ds = 0$$

On putting the values of the integrals in (3), we have

$$\int_{a-ir}^{a+ir} \frac{e^{xs-b\sqrt{x}}}{s} ds + \int_{\epsilon}^p \frac{e^{-xR} (e^{ib\sqrt{R}} - e^{-ib\sqrt{R}})}{R} dR - 2\pi i = 0$$

$$\Rightarrow \int_{a-i\infty}^{a+i\infty} \frac{e^{xs-b\sqrt{x}}}{s} ds = 2\pi i - 2i \int_0^{\infty} \frac{e^{-xR} \sin b\sqrt{R}}{R} dR \quad \left(\begin{array}{l} \epsilon \rightarrow 0 \\ p \rightarrow \infty \end{array} \right)$$

$$\Rightarrow \frac{1}{2\pi i} \int_{a-i\infty}^{a+i\infty} \frac{e^{xs-b\sqrt{x}}}{s} ds = 1 - \frac{2}{\pi} \int_0^{\infty} e^{-u^2} \frac{\sin\left(\frac{bu}{\sqrt{x}}\right)}{u} du \quad \left(\begin{array}{l} u^2 \\ R = \frac{u^2}{x} \end{array} \right) \dots(4)$$

We know that $\int_0^{\infty} e^{-u^2} \cos 2bu \, du = \frac{1}{2} \sqrt{\pi} e^{-b^2}$

Integrating both sides w.r.t., "b"

$$\int_0^{\infty} e^{-u^2} \left[\frac{\sin 2bu}{2u} \right] du = \frac{1}{2} \sqrt{\pi} \int e^{-b^2} db$$

Taking limits 0 to $\frac{b}{2\sqrt{x}}$, we have

$$\int_0^{\infty} e^{-u^2} \left(\frac{\sin 2bu}{2u} \right) \Big|_0^{\frac{b}{2\sqrt{x}}} du = \frac{\sqrt{\pi}}{2} \int_0^{\frac{b}{2\sqrt{x}}} e^{-b^2} db$$

$$\int_0^{\infty} e^{-u^2} \frac{\sin \frac{bu}{\sqrt{x}}}{u} du = \sqrt{\pi} \cdot \frac{\sqrt{x}}{2} e.r.f. \left(\frac{b}{2\sqrt{x}} \right)$$

$$= \frac{\pi}{2} e.r.f. \left(\frac{b}{2\sqrt{x}} \right)$$

$$\left[\begin{array}{l} 2 \int_0^x e^{-u^2} \\ e.r.f. x = \frac{1}{\sqrt{\pi}} \int_0^x e^{-u^2} du \end{array} \right]$$

Putting the value of the above integral in (4), we have

$$\frac{1}{2\pi i} \int_{a-i\infty}^{a+i\infty} e^{xs} \frac{e^{-b\sqrt{x}}}{s} ds = 1 - \frac{2}{\pi} \frac{\pi}{2} e.r.f. \left(\frac{b}{2\sqrt{x}} \right)$$

$$= 1 - e.r.f. \left(\frac{b}{2\sqrt{x}} \right)$$

Ans.

Exercise 13.18

Find the inverse of the following by convolution theorem

- | | | | |
|------------------------------|---|------------------------------|--------------------------------|
| 1. $\frac{1}{(s^2 + a^2)^2}$ | Ans. $\frac{1}{2} \left[\begin{array}{l} t \cos at + \frac{1}{2a} \sin at \end{array} \right]$ | 2. $\frac{1}{s(s^2 + a^2)}$ | Ans. $\frac{1 - \cos at}{a^2}$ |
| 3. $\frac{1}{(s^2 + 1)^3}$ | Ans. $\frac{1}{8} \left[(3-t^2) \sin t - 3t \cos t \right]$ | 4. $\frac{s}{(s^2 + a^2)^2}$ | Ans. $\frac{1}{2a} t \sin at$ |

Find the Laplace transform of the following.

- | | | | |
|---------------------|---|---------------|------------------------------------|
| 5. $e^{ax} J_0(bx)$ | Ans. $\frac{1}{\sqrt{s^2 + 2as + a^2 + b^2}}$ | 6. $xJ_0(ax)$ | Ans. $\frac{s}{(s^2 + a^2)^{3/2}}$ |
|---------------------|---|---------------|------------------------------------|

Laplace Transformation

7. $xJ_1(x)$

Ans. $\frac{1}{(s+1)^{3/2}}$

Find the inverse Laplace transform of the following by residue method:

8. $\frac{1}{(s+1)(s+2)}$

Ans. $e^{-t} - e^{-2t}$

9. $\frac{1}{(s-1)(s^2+1)}$

Ans. $\frac{1}{2}(e^t - \sin t - \cos t)$

10. $\frac{4s+5}{(s+2)(s-1)}$

Ans. $3te^t + \frac{1}{3}e^t - \frac{1}{3}e^{-2t}$

11. $\frac{1}{(s-1)^2(s^2+1)}$

Ans. $e^t(t-1) + \cos t$

12. $\frac{\cosh x\sqrt{s}}{\sqrt{s}}, 0 < x < 1$

Ans. $-\sum_{n=1}^{\infty} \frac{(-1)^n}{2n-1} e^{-\frac{(2n-1)^2 \pi^2 t}{4}} \cos\left(n - \frac{1}{2}\right) \pi x + 1$

13. $\frac{\sinh x\sqrt{s}}{x \sinh \sqrt{s}}$

Ans. $x + \frac{2}{\pi} \sum_{n=1}^{\infty} \frac{(-1)^n}{n} e^{-n^2 \pi^2 t} \cdot \sin n\pi x$

14. Prove that $L^{-1}\left\{\frac{e^{-a\sqrt{s}}}{\sqrt{s}}\right\} = \frac{1}{\sqrt{\pi t}} \cdot e^{-\frac{a^2}{4t}}$

15. $e^{\sqrt{-s}}$

Ans. $\frac{1}{2\sqrt{\pi}} t^{-\frac{3}{2}} e^{-\frac{1}{4t}}$

$\frac{F(s)}{G(s)}$

HEAVISIDE'S Inverse Formula of

If $F(s)$ and $G(s)$ be two polynomials in s . The degree of $F(s)$ is less than that of $G(s)$. Let $\alpha_1, \alpha_2, \alpha_3, \dots, \alpha_n$ be n roots of the equation $G(s) = 0$

Inverse Laplace formula of $\frac{F(s)}{G(s)}$ is given by $L^{-1}\left\{\frac{F(s)}{G(s)}\right\} = \sum_{i=1}^n \frac{F(\alpha_i)}{G'(\alpha_i)} e^{\alpha_i t}$

Example 65. Find $L^{-1}\left\{\frac{2s^2+5s-4}{s^3+s^2-2s}\right\}$

Solution. Let $F(s) = 2s^2 + 5s - 4$
and $G(s) = s^3 + s^2 - 2s = s(s^2 + s - 2) = s(s+2)(s-1)$
 $G'(s) = 3s^2 + 2s - 2$
 $G(s) = 0$ has three roots, 0, 1, -2.

or $\alpha_1 = 0, \alpha_2 = 1, \alpha_3 = -2$
By Heaviside's Inverse formula $L^{-1}\left\{\frac{F(s)}{G(s)}\right\} = \sum_{i=1}^n \frac{F(\alpha_i)}{G'(\alpha_i)} e^{\alpha_i t}$

$= \frac{F(\alpha_1)}{G'(\alpha_1)} e^{\alpha_1 t} + \frac{F(\alpha_2)}{G'(\alpha_2)} e^{\alpha_2 t} + \frac{F(\alpha_3)}{G'(\alpha_3)} e^{\alpha_3 t} = \frac{F(0)}{G'(0)} e^0 + \frac{F(1)}{G'(1)} e^t + \frac{F(-2)}{G'(-2)} e^{-2t}$
 $= \frac{-4}{-2} e^0 + \frac{3}{3} e^t + \frac{(-6)}{6} e^{-2t} = 2 + e^t - e^{-2t}$

Ans.

Exercise 13.19

Using Heaviside's expansion formula, find the inverse Laplace transform of the following:

1. $\frac{s-1}{s^2+3s+2}$

Ans. $-2e^{-t} + 3e^{-2t}$

2. $\frac{s}{(s-1)(s-2)(s-3)}$

Ans. $\frac{1}{2}e^t - 2e^{2t} + \frac{3}{2}e^{3t}$

3. $\frac{2s+3}{(s-2)(s-3)(s-4)}$

Ans. $\frac{7}{2}e^{2t} - 9e^{3t} + \frac{11}{2}e^{4t}$

4. $\frac{11s^2-2s+5}{2s^3-3s^2-3s+2}$

Ans. $2e^{-2t} + 5e^{2t} - \frac{3}{2}e^{\frac{1}{2}t}$

UNIT-4 Vector Differentiation

VECTORS

A vector is a quantity having both magnitude and direction such as force, velocity, acceleration, displacement etc.

ADDITION OF VECTORS

Let \vec{a} and \vec{b} be two given vectors.

$\vec{OA} = \vec{a}$ and $\vec{AB} = \vec{b}$ then vector \vec{OB} is called the

sum of \vec{a} and \vec{b} .

Symbolically

$$\vec{OA} + \vec{AB} = \vec{OB}$$

$$\vec{a} + \vec{b} = \vec{OB}$$

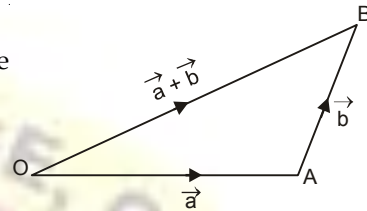

RECTANGULAR RESOLUTION OF A VECTOR

Let OX, OY, OZ be the three rectangular axes. Let $\hat{i}, \hat{j}, \hat{k}$ be three unit vectors and parallel to three axes.

If $\vec{OP} = \vec{r}$ and the co-ordinates of P be (x, y, z)

$$\vec{OA} = x\hat{i}, \quad \vec{OB} = y\hat{j} \quad \text{and} \quad \vec{OC} = z\hat{k}$$

$$\vec{OP} = \vec{OF} + \vec{FP}$$

$$\Rightarrow \vec{OP} = (\vec{OA} + \vec{AF}) + \vec{FP}$$

$$\Rightarrow \vec{OP} = \vec{OA} + \vec{OB} + \vec{OC}$$

$$\vec{r} = x\hat{i} + y\hat{j} + z\hat{k}$$

$$\Rightarrow OP^2 = OF^2 + FP^2$$

$$= (OA^2 + AF^2) + FP^2 = OA^2 + OB^2 + OC^2 = x^2 + y^2 + z^2$$

$$OP = \sqrt{x^2 + y^2 + z^2}$$

$$|\vec{r}| = \sqrt{x^2 + y^2 + z^2}$$

UNIT VECTOR

Let a vector be $x\hat{i} + y\hat{j} + z\hat{k}$.

$$\text{Unit vector} = \frac{x\hat{i} + y\hat{j} + z\hat{k}}{\sqrt{x^2 + y^2 + z^2}}$$

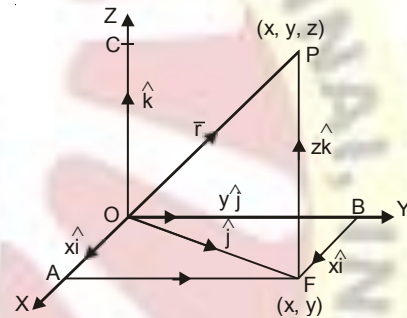

Vectors

Example 1. If \vec{a} and \vec{b} be two unit vectors and α be the angle between them, then find the value of α such that $\vec{a} + \vec{b}$ is a unit vector. (Nagpur, University, Winter 2001)

Solution. Let $\vec{OA} = \vec{a}$ be a unit vector and $\vec{AB} = \vec{b}$ is another unit vector and α be the angle between \vec{a} and \vec{b} .

If $\vec{OB} = \vec{c} = \vec{a} + \vec{b}$ is also a unit vector then, we have

$$|\vec{OA}| = 1$$

$$|\vec{AB}| = 1$$

$$|\vec{OB}| = 1$$

OAB is an equilateral triangle.

So, each angle of ΔOAB is $\frac{\pi}{3}$

$$\text{Hence } \alpha = \pi - \frac{\pi}{3} = \frac{2\pi}{3}$$

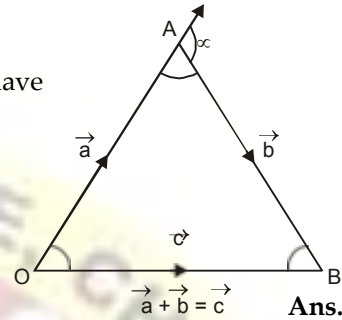

Ans.

POSITION VECTOR OF A POINT

The position vector of a point A with respect to origin O is the vector \vec{OA} which is used to specify the position of A w.r.t. O .

To find \vec{AB} if the position vectors of the point A and point B are given.

If the position vectors of A and B are \vec{a} and \vec{b} . Let the origin be O .

Then $\vec{OA} = \vec{a}$, $\vec{OB} = \vec{b}$

$$\vec{OA} + \vec{AB} = \vec{OB}$$

$$\vec{AB} = \vec{OB} - \vec{OA}$$

$$\Rightarrow \vec{AB} = \vec{b} - \vec{a}$$

$$\vec{AB} = \text{Position vector of } B - \text{Position vector of } A$$

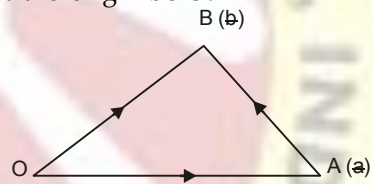

Example 2. If A and B are $(3, 4, 5)$ and $(6, 8, 9)$, find \vec{AB} .

Solution. $\vec{AB} = \text{Position vector of } B - \text{Position vector of } A$

$$= (6\hat{i} + 8\hat{j} + 9\hat{k}) - (3\hat{i} + 4\hat{j} + 5\hat{k}) = 3\hat{i} + 4\hat{j} + 4\hat{k}$$

Ans.

RATIO FORMULA

To find the position vector of the point which divides the line joining two given points.

Let A and B be two points and a point C divides AB in the ratio of $m : n$.

Let O be the origin, then

$$\vec{OA} = \vec{a}, \text{ and } \vec{OB} = \vec{b}, \quad \vec{OC} = ?$$

$$\vec{OC} = \vec{OA} + \vec{AC}$$

$$= \vec{OA} + \frac{m}{m+n} \vec{AB} \quad \left(\because \vec{AC} = \frac{m}{m+n} \vec{AB} \right)$$

$$= \vec{a} + \frac{m}{m+n} (\vec{b} - \vec{a}) \quad \left(\because \vec{AB} = \vec{b} - \vec{a} \right)$$

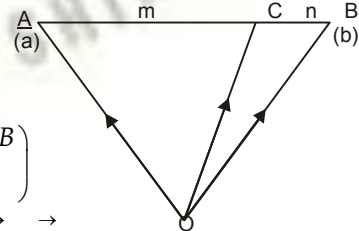

$$\vec{OC} = \frac{m\vec{b} + n\vec{a}}{m+n}$$

Cor. If $m = n = 1$, then \vec{C} will be the mid-point, and

$$\vec{OC} = \frac{\vec{a} + \vec{b}}{2}$$

PRODUCT OF TWO VECTORS

The product of two vectors results in two different ways, the one is a number and the other is vector. So, there are two types of product of two vectors, namely scalar product and vector product. They are written as $\vec{a} \cdot \vec{b}$ and $\vec{a} \times \vec{b}$.

SCALAR, OR DOT PRODUCT

The scalar, or dot product of two vectors \vec{a} and \vec{b} is defined to be $|\vec{a}| |\vec{b}| \cos \theta$ i.e., scalar where θ is the angle between \vec{a} and \vec{b} .

Symbolically, $\vec{a} \cdot \vec{b} = |\vec{a}| |\vec{b}| \cos \theta$

Due to a dot between \vec{a} and \vec{b} this product is also called dot product.

The scalar product is commutative

To Prove. $\vec{a} \cdot \vec{b} = \vec{b} \cdot \vec{a}$

Proof. $\vec{b} \cdot \vec{a} = |\vec{b}| |\vec{a}| \cos(-\theta)$
 $= |\vec{a}| |\vec{b}| \cos \theta$
 $= \vec{a} \cdot \vec{b}$ **Proved.**

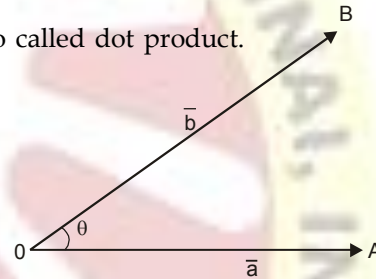

Geometrical interpretation. The scalar product of two vectors is the product of one vector and the length of the projection of the other in the direction of the first.

Let $OA = \vec{a}$ and $OB = \vec{b}$
 then $\vec{a} \cdot \vec{b} = (OA) \cdot (OB) \cos \theta$
 $= OA \cdot OB \cdot \frac{ON}{OB}$
 $= OA \cdot ON$
 $= (\text{Length of } \vec{a}) (\text{projection of } \vec{b} \text{ along } \vec{a})$

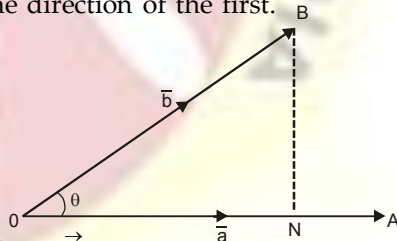

USEFUL RESULTS

$\hat{i} \cdot \hat{i} = (1)(1) \cos 0^\circ = 1$ Similarly, $\hat{j} \cdot \hat{j} = 1, \hat{k} \cdot \hat{k} = 1$

$\hat{i} \cdot \hat{j} = (1)(1) \cos 90^\circ = 0$ Similarly, $\hat{j} \cdot \hat{k} = 0, \hat{k} \cdot \hat{i} = 0$

Note. If the dot product of two vectors is zero then vectors are perpendicular to each other.

WORK DONE AS A SCALAR PRODUCT

If a constant force F acting on a particle displaces it from A to B then,

Work done = (component of F along AB). Displacement
 $= F \cos \theta \cdot AB$
 $= \vec{F} \cdot \vec{AB}$

Work done = Force . Displacement

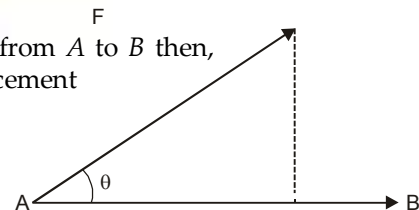

Vectors

VECTOR PRODUCT OR CROSS PRODUCT

1. The vector, or cross product of two vectors \vec{a} and \vec{b} is defined to be a vector such that

(i) Its magnitude is $|\vec{a}||\vec{b}|\sin\theta$, where θ is the angle between \vec{a} and \vec{b} .

(ii) Its direction is perpendicular to both vectors \vec{a} and \vec{b} .

(iii) It forms with a right handed system.

Let $\hat{\eta}$ be a unit vector perpendicular to both the vectors \vec{a} and \vec{b} .

$$\vec{a} \times \vec{b} = |\vec{a}||\vec{b}|\sin\theta \cdot \hat{\eta}$$

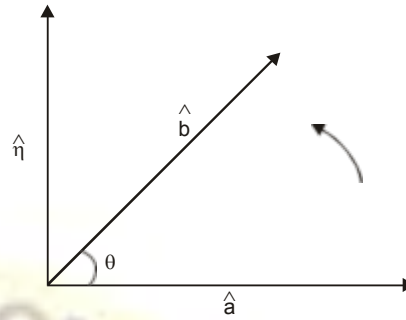

2. Useful results

Since $\hat{i}, \hat{j}, \hat{k}$ are three mutually perpendicular unit vectors, then

$$\hat{i} \times \hat{i} = \hat{j} \times \hat{j} = \hat{k} \times \hat{k} = 0$$

$$\hat{i} \times \hat{j} = \hat{k}$$

$$\hat{j} \times \hat{k} = \hat{i}$$

$$\hat{k} \times \hat{i} = \hat{j}$$

$$\hat{j} \times \hat{i} = -\hat{k}$$

$$\hat{k} \times \hat{j} = -\hat{i}$$

$$\hat{i} \times \hat{k} = -\hat{j}$$

VECTOR PRODUCT EXPRESSED AS A DETERMINANT

$$\begin{aligned} \vec{a} &= a_1 \hat{i} + a_2 \hat{j} + a_3 \hat{k} \\ \vec{b} &= b_1 \hat{i} + b_2 \hat{j} + b_3 \hat{k} \\ \vec{a} \times \vec{b} &= \begin{vmatrix} \hat{i} & \hat{j} & \hat{k} \\ a_1 & a_2 & a_3 \\ b_1 & b_2 & b_3 \end{vmatrix} \\ &= a_1 b_2 (\hat{i} \times \hat{j}) + a_1 b_3 (\hat{i} \times \hat{k}) + a_2 b_1 (\hat{j} \times \hat{i}) + a_2 b_3 (\hat{j} \times \hat{k}) \\ &\quad + a_3 b_1 (\hat{k} \times \hat{i}) + a_3 b_2 (\hat{k} \times \hat{j}) \\ &= a_1 b_2 \hat{k} - a_1 b_3 \hat{j} - a_2 b_1 \hat{k} + a_2 b_3 \hat{i} + a_3 b_1 \hat{j} - a_3 b_2 \hat{i} \\ &= (a_2 b_3 - a_3 b_2) \hat{i} - (a_1 b_3 - a_3 b_1) \hat{j} + (a_1 b_2 - a_2 b_1) \hat{k} \\ &= \begin{vmatrix} \hat{i} & \hat{j} & \hat{k} \\ a_1 & a_2 & a_3 \\ b_1 & b_2 & b_3 \end{vmatrix} \end{aligned}$$

AREA OF PARALLELOGRAM

Example 3. Find the area of a parallelogram whose adjacent sides are $\vec{i} - 2\vec{j} + 3\vec{k}$ and $2\vec{i} + \vec{j} - 4\vec{k}$.

Solution. Vector area of \cdot gm = $\begin{vmatrix} \hat{i} & \hat{j} & \hat{k} \\ 1 & -2 & 3 \\ 2 & 1 & -4 \end{vmatrix}$

$$= (8 - 3)\hat{i} - (-4 - 6)\hat{j} + (1 + 4)\hat{k} = 5\hat{i} + 10\hat{j} + 5\hat{k}$$

Area of parallelogram = $\sqrt{(5)^2 + (10)^2 + (5)^2} = 5\sqrt{6}$

Ans.

MOMENT OF A FORCE

Let a force \vec{F} (PQ) act at a point P.

Moment of \vec{F} about O

= Product of force F and perpendicular distance (ON. $\hat{\eta}$)

$$= (PQ) (ON)(\hat{\eta}) = (PQ) (OP) \sin \theta (\hat{\eta}) = \vec{OP} \times \vec{PQ}$$

$$\Rightarrow \vec{M} = \vec{r} \times \vec{F}$$

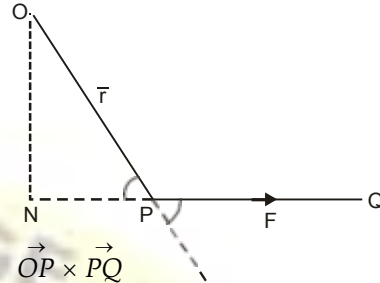

ANGULAR VELOCITY

Let a rigid body be rotating about the axis OA with the angular velocity ω which is a vector and its magnitude is ω radians per second and its direction is parallel to the axis of rotation OA.

Let P be any point on the body such that $\vec{OP} = \vec{r}$ and $\angle AOP = \theta$ and $AP \perp OA$. Let the velocity of P be V.

Let $\hat{\eta}$ be a unit vector perpendicular to $\vec{\omega}$ and r .

$$\vec{\omega} \times \vec{r} = (\omega r \sin \theta) \hat{\eta} = (\omega AP) \hat{\eta} = (\text{Speed of P}) \hat{\eta}$$

= Velocity of P \perp to $\vec{\omega}$ and r

Hence $\vec{V} = \vec{\omega} \times \vec{r}$

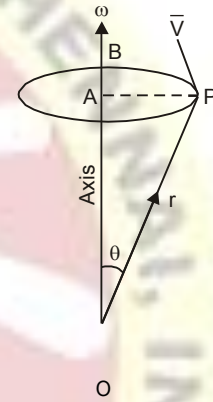

SCALAR TRIPLE PRODUCT

Let a, b, c be three vectors then their dot product is written as $a \cdot (b \times c)$ or $[a \ b \ c]$.
If $\vec{a} = a_1 \hat{i} + a_2 \hat{j} + a_3 \hat{k}$, $\vec{b} = b_1 \hat{i} + b_2 \hat{j} + b_3 \hat{k}$, and $\vec{c} = c_1 \hat{i} + c_2 \hat{j} + c_3 \hat{k}$

$$\begin{aligned} \vec{a} \cdot (\vec{b} \times \vec{c}) &= (a_1 \hat{i} + a_2 \hat{j} + a_3 \hat{k}) \cdot [(b_1 \hat{i} + b_2 \hat{j} + b_3 \hat{k}) \times (c_1 \hat{i} + c_2 \hat{j} + c_3 \hat{k})] \\ &= (a_1 \hat{i} + a_2 \hat{j} + a_3 \hat{k}) \cdot [(b_2 c_3 - b_3 c_2) \hat{i} + (b_3 c_1 - b_1 c_3) \hat{j} + (b_1 c_2 - b_2 c_1) \hat{k}] \\ &= a_1 (b_2 c_3 - b_3 c_2) + a_2 (b_3 c_1 - b_1 c_3) + a_3 (b_1 c_2 - b_2 c_1) \end{aligned}$$

$$= \begin{vmatrix} a_1 & a_2 & a_3 \\ b_1 & b_2 & b_3 \\ c_1 & c_2 & c_3 \end{vmatrix}$$

Similarly, $\vec{b} \cdot (\vec{c} \times \vec{a})$ and $\vec{c} \cdot (\vec{a} \times \vec{b})$ have the same value.

$$\therefore \vec{a} \cdot (\vec{b} \times \vec{c}) = \vec{b} \cdot (\vec{c} \times \vec{a}) = \vec{c} \cdot (\vec{a} \times \vec{b})$$

The value of the product depends upon the cyclic order of the vector, but is independent of the position of the dot and cross. These may be interchanged.

The value of the product changes if the order is non-cyclic.

Note. $\vec{a} \times (\vec{b} \cdot \vec{c})$ and $(\vec{a} \cdot \vec{b}) \times \vec{c}$ are meaningless.

Vectors

GEOMETRICAL INTERPRETATION

The scalar triple product $\vec{a} \cdot (\vec{b} \times \vec{c})$ represents the volume of the parallelepiped having $\vec{a}, \vec{b}, \vec{c}$ as its co-terminous edges.

$\vec{a} \cdot (\vec{b} \times \vec{c}) = \vec{a} \cdot \hat{n}$
 = Area of gm $OBDC \times$ perpendicular distance between the parallel faces $OBDC$ and $AEFG$.
 = Volume of the parallelepiped

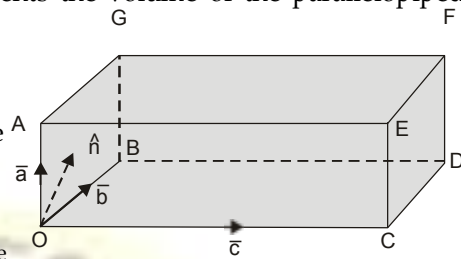

Note. (1) If $\vec{a} \cdot (\vec{b} \times \vec{c}) = 0$, then $\vec{a}, \vec{b}, \vec{c}$ are coplanar.

(2) Volume of tetrahedron $\frac{1}{6} (\vec{a} \cdot (\vec{b} \times \vec{c}))$.

Example 4. Find the volume of parallelepiped if

$\vec{a} = -3\hat{i} + 7\hat{j} + 5\hat{k}$, $\vec{b} = -3\hat{i} + 7\hat{j} - 3\hat{k}$, and $\vec{c} = 7\hat{i} - 5\hat{j} - 3\hat{k}$ are the three co-terminous edges of the parallelepiped.

Solution.

$$\begin{aligned} \text{Volume} &= \vec{a} \cdot (\vec{b} \times \vec{c}) \\ &= \begin{vmatrix} -3 & 7 & 5 \\ -3 & 7 & -3 \\ 7 & -5 & -3 \end{vmatrix} = -3(-21 - 15) - 7(9 + 21) + 5(15 - 49) \\ &= 108 - 210 - 170 = -272 \end{aligned}$$

Volume = 272 cube units.

Ans.

Example 5. Show that the volume of the tetrahedron having $\vec{A} + \vec{B}, \vec{B} + \vec{C}, \vec{C} + \vec{A}$ as concurrent edges is twice the volume of the tetrahedron having $\vec{A}, \vec{B}, \vec{C}$ as concurrent edges.

Solution. Volume of tetrahedron = $\frac{1}{6} (\vec{A} + \vec{B}) \cdot [(\vec{B} + \vec{C}) \times (\vec{C} + \vec{A})]$

$$= \frac{1}{6} (\vec{A} + \vec{B}) \cdot [\vec{B} \times \vec{C} + \vec{B} \times \vec{A} + \vec{C} \times \vec{C} + \vec{C} \times \vec{A}] \quad [C \times C = 0]$$

$$= \frac{1}{6} (\vec{A} + \vec{B}) \cdot (\vec{B} \times \vec{C} + \vec{B} \times \vec{A} + \vec{C} \times \vec{A})$$

$$= \frac{1}{6} [A \cdot (B \times C) + A \cdot (B \times A) + A \cdot (C \times A) + B \cdot (B \times C) + B \cdot (B \times A) + B \cdot (C \times A)]$$

$$= \frac{1}{6} [A \cdot (B \times C) + B \cdot (C \times A)] = \frac{1}{3} A \cdot (B \times C)$$

$$= 2 \times \frac{1}{6} [A B C]$$

= 2 Volume of tetrahedron having A, B, C , as concurrent edges. **Proved.**

EXERCISE 5.1

1. Find the volume of the parallelepiped with adjacent sides.

$$\vec{OA} = 3\hat{i} - \hat{j}, \quad \vec{OB} = \hat{j} + 2\hat{k}, \quad \text{and} \quad \vec{OC} = \hat{i} + 5\hat{j} + 4\hat{k}$$

extending from the origin of co-ordinates O .

Ans. 20

2. Find the volume of the tetrahedron whose vertices are the points $A(2, -1, -3), B(4, 1, 3)$

$C(3, 2, -1)$ and $D(1, 4, 2)$.

Ans. $7 \frac{1}{3}$

Vectors

3. Choose y in order that the vectors $\vec{a} = 7\hat{i} + y\hat{j} + \hat{k}$, $\vec{b} = 3\hat{i} + 2\hat{j} + \hat{k}$, $\vec{c} = 5\hat{i} + 3\hat{j} + \hat{k}$ are linearly dependent.

Ans. $y = 4$

4. Prove that $[a + b, b + c, c + a] = 2[a b c]$

COPLANARITY QUESTIONS

Example 6. Find the volume of tetrahedron having vertices

$$(-\hat{j} - \hat{k}), (4\hat{i} + 5\hat{j} + q\hat{k}), (3\hat{i} + 9\hat{j} + 4\hat{k}) \text{ and } 4(-\hat{i} + \hat{j} + \hat{k}).$$

Also find the value of q for which these four points are coplanar.

(Nagpur University, Summer 2004, 2003, 2002)

Solution. Let $\vec{A} = -\hat{j} - \hat{k}$, $\vec{B} = 4\hat{i} + 5\hat{j} + q\hat{k}$, $\vec{C} = 3\hat{i} + 9\hat{j} + 4\hat{k}$, $\vec{D} = 4(-\hat{i} + \hat{j} + \hat{k})$

$$\vec{AB} = \vec{B} - \vec{A} = 4\hat{i} + 5\hat{j} + q\hat{k} - (-\hat{j} - \hat{k}) = 4\hat{i} + 6\hat{j} + (q+1)\hat{k}$$

$$\vec{AC} = \vec{C} - \vec{A} = (3\hat{i} + 9\hat{j} + 4\hat{k}) - (-\hat{j} - \hat{k}) = 3\hat{i} + 10\hat{j} + 5\hat{k}$$

$$\vec{AD} = \vec{D} - \vec{A} = 4(-\hat{i} + \hat{j} + \hat{k}) - (-\hat{j} - \hat{k}) = -4\hat{i} + 5\hat{j} + 5\hat{k}$$

$$\text{Volume of the tetrahedron} = \frac{1}{6} [\vec{AB} \vec{AC} \vec{AD}]$$

$$= \frac{1}{6} \begin{vmatrix} 4 & 6 & q+1 \\ 3 & 10 & 5 \\ -4 & 5 & 5 \end{vmatrix} = \frac{1}{6} \{4(50 - 25) - 6(15 + 20) + (q+1)(15 + 40)\}$$

$$= \frac{1}{6} \{100 - 210 + 55(q+1)\} = \frac{1}{6} (-110 + 55 + 55q)$$

$$= \frac{1}{6} (-55 + 55q) = \frac{55}{6} (q-1)$$

If four points A, B, C and D are coplanar, then $(\vec{AB} \vec{AC} \vec{AD}) = 0$
i.e., Volume of the tetrahedron = 0

$$\Rightarrow \frac{55}{6} (q-1) = 0 \Rightarrow q = 1$$

Ans.

Example 7. If four points whose position vectors are $\vec{a}, \vec{b}, \vec{c}, \vec{d}$ are coplanar, show that

$$[a b c] = [a d b] + [a d c] + [d b c] \text{ (Nagpur University, Summer 2005)}$$

Solution. Let A, B, C, D be four points whose position vectors are $\vec{a}, \vec{b}, \vec{c}, \vec{d}$.

$$\vec{AD} = \vec{d} - \vec{a}, \quad \vec{BD} = \vec{d} - \vec{b} \quad \text{and} \quad \vec{CD} = \vec{d} - \vec{c}$$

If AD, BD, CD are coplanar, then

$$\vec{AD} \cdot (\vec{BD} \times \vec{CD}) = 0$$

$$\Rightarrow (\vec{d} - \vec{a}) \cdot [(\vec{d} - \vec{b}) \times (\vec{d} - \vec{c})] = 0$$

$$\Rightarrow (\vec{d} - \vec{a}) \cdot [\vec{d} \times \vec{d} - \vec{d} \times \vec{c} - \vec{b} \times \vec{d} + \vec{b} \times \vec{c}] = 0$$

$$\Rightarrow (\vec{d} - \vec{a}) \cdot [-\vec{d} \times \vec{c} - \vec{b} \times \vec{d} + \vec{b} \times \vec{c}] = 0$$

$$\Rightarrow -\vec{d} \cdot (\vec{d} \times \vec{c}) - \vec{d} \cdot (\vec{b} \times \vec{d}) + \vec{d} \cdot (\vec{b} \times \vec{c}) + \vec{a} \cdot (\vec{d} \times \vec{c}) + \vec{a} \cdot (\vec{b} \times \vec{d}) - \vec{a} \cdot (\vec{b} \times \vec{c}) = 0$$

$$\Rightarrow 0 + 0 + [d b c] + [d d c] + [d b d] - [a b c] = 0$$

$$\Rightarrow [a b c] = [a b d] + [a d c] + [d b c] \quad \text{Proved.}$$

Vectors

EXERCISE 5.2

- Determine λ such that $\vec{a} = \hat{i} + \hat{j} + \hat{k}$, $\vec{b} = 2\hat{i} - 4\hat{k}$, and $\vec{c} = \hat{i} + \lambda\hat{j} + 3\hat{k}$ are coplanar. **Ans.** $\lambda = 5/3$
- Show that the four points $(-6, 3, 2)$, $(3, -2, 4)$, $(5, 7, 3)$ and $(-13, 17, -1)$ are coplanar.
- Find the constant a such that the vectors $2\hat{i} - \hat{j} + \hat{k}$, $\hat{i} + 2\hat{j} - 3\hat{k}$, and $3\hat{i} + a\hat{j} + 5\hat{k}$ are coplanar. **Ans.** -4
- Prove that four points $(4, 5, 1)$, $(-1, 1, 3)$, $(3, 9, 4)$ and $(-1, 1, 4)$ are coplanar.
- If the vectors \vec{a} , \vec{b} and \vec{c} are coplanar, show that

$$\begin{vmatrix} \vec{a} & \vec{b} & \vec{c} \\ \vec{a} \cdot \vec{a} & \vec{a} \cdot \vec{b} & \vec{a} \cdot \vec{c} \\ \vec{b} \cdot \vec{a} & \vec{b} \cdot \vec{b} & \vec{b} \cdot \vec{c} \end{vmatrix} = 0$$

VECTOR PRODUCT OF THREE VECTORS

(A.M.I.E.T.E., Summer, 2004, 2000)

Let \vec{a} , \vec{b} and \vec{c} be three vectors then their vector product is written as $\vec{a} \times (\vec{b} \times \vec{c})$

Let $\vec{a} = a_1\hat{i} + a_2\hat{j} + a_3\hat{k}$,
 $\vec{b} = b_1\hat{i} + b_2\hat{j} + b_3\hat{k}$,
 $\vec{c} = c_1\hat{i} + c_2\hat{j} + c_3\hat{k}$

$$\begin{aligned} \vec{a} \times (\vec{b} \times \vec{c}) &= (a_1\hat{i} + a_2\hat{j} + a_3\hat{k}) \times (b_1\hat{i} + b_2\hat{j} + b_3\hat{k}) \times (c_1\hat{i} + c_2\hat{j} + c_3\hat{k}) \\ &= (a_1\hat{i} + a_2\hat{j} + a_3\hat{k}) \times [(b_2c_3 - b_3c_2)\hat{i} + (b_3c_1 - b_1c_3)\hat{j} + (b_1c_2 - b_2c_1)\hat{k}] \\ &= [a_1(b_2c_3 - b_3c_2) - a_2(b_3c_1 - b_1c_3) + a_3(b_1c_2 - b_2c_1)]\hat{i} \\ &\quad + [a_2(b_3c_1 - b_1c_3) - a_3(b_1c_2 - b_2c_1)]\hat{j} \\ &\quad + [a_3(b_1c_2 - b_2c_1) - a_1(b_2c_3 - b_3c_2)]\hat{k} \\ &= (a_1c_2 + a_2c_3 + a_3c_1)(b_1\hat{i} + b_2\hat{j} + b_3\hat{k}) - (a_1b_2 + a_2b_3 + a_3b_1)(c_1\hat{i} + c_2\hat{j} + c_3\hat{k}) \\ &= (a \cdot c)b - (a \cdot b)c. \end{aligned}$$

Ans.

Example 8. Prove that : $\vec{a} \times (\vec{b} \times \vec{c}) + \vec{b} \times (\vec{c} \times \vec{a}) + \vec{c} \times (\vec{a} \times \vec{b}) = 0$ (Nagpur University, Winter 2008)

Solution. Here, we have

$$\begin{aligned} &\vec{a} \times (\vec{b} \times \vec{c}) + \vec{b} \times (\vec{c} \times \vec{a}) + \vec{c} \times (\vec{a} \times \vec{b}) \\ &= [(a \cdot c)b - (a \cdot b)c] + [(b \cdot a)c - (b \cdot c)a] + [(c \cdot b)a - (c \cdot a)b] \\ &= [(b \cdot a)c - (a \cdot b)c] + [(c \cdot b)a - (b \cdot c)a] + [(a \cdot c)b - (c \cdot a)b] \\ &= [(a \cdot b)c - (a \cdot b)c] + [(b \cdot c)a - (b \cdot c)a] + [(c \cdot a)b - (c \cdot a)b] \\ &= 0 + 0 + 0 = 0 \end{aligned}$$

Proved.

Example 9. Prove that : $\hat{i} \times (\hat{a} \times \hat{i}) + \hat{j} \times (\hat{a} \times \hat{j}) + \hat{k} \times (\hat{a} \times \hat{k}) = 2\hat{a}$ (Nagpur University, Winter 2003)

Solution. Let $\hat{a} = a_1\hat{i} + a_2\hat{j} + a_3\hat{k}$

Vectors

Now, L.H.S. = $\hat{i} \times (a_1 \hat{i} + a_2 \hat{j} + a_3 \hat{k}) + \hat{j} \times (a_1 \hat{i} + a_2 \hat{j} + a_3 \hat{k}) + \hat{k} \times (a_1 \hat{i} + a_2 \hat{j} + a_3 \hat{k})$

$$= \hat{i} \times [a_1 \hat{i} + a_2 \hat{j} + a_3 \hat{k}] + \hat{j} \times [a_1 \hat{i} + a_2 \hat{j} + a_3 \hat{k}] + \hat{k} \times [a_1 \hat{i} + a_2 \hat{j} + a_3 \hat{k}]$$

$$= \hat{i} [a_1(\hat{i} \times \hat{i}) + a_2(\hat{j} \times \hat{i}) + a_3(\hat{k} \times \hat{i})] + \hat{j} [a_1(\hat{i} \times \hat{j}) + a_2(\hat{j} \times \hat{j}) + a_3(\hat{k} \times \hat{j})] + \hat{k} [a_1(\hat{i} \times \hat{k}) + a_2(\hat{j} \times \hat{k}) + a_3(\hat{k} \times \hat{k})]$$

$$= \hat{i} [0 - a_2 \hat{k} + a_3 \hat{j}] + \hat{j} [a_1 \hat{k} + 0 - a_3 \hat{i}] + \hat{k} [-a_1 \hat{j} + a_2 \hat{i} + 0]$$

$$= -a_2(\hat{i} \times \hat{k}) + a_3(\hat{i} \times \hat{j}) + a_1(\hat{j} \times \hat{k}) - a_3(\hat{j} \times \hat{i}) - a_1(\hat{k} \times \hat{j}) + a_2(\hat{k} \times \hat{i})$$

$$= a_2 \hat{j} + a_3 \hat{k} + a_1 \hat{i} + a_3 \hat{k} + a_1 \hat{i} + a_2 \hat{j} = 2a_1 \hat{i} + 2a_2 \hat{j} + 2a_3 \hat{k}$$

$$= 2(a_1 \hat{i} + a_2 \hat{j} + a_3 \hat{k}) = 2\vec{a}$$

Proved.

Example 10. Show that for any scalar λ , the vectors x, y given by

$$\vec{x} = \lambda \vec{a} + \frac{q(\vec{a} \times \vec{b})}{a^2}, \vec{y} = \frac{(1-p\lambda)\vec{a}}{q} - \frac{p(\vec{a} \times \vec{b})}{a^2}$$

satisfy the equations

$$p\vec{x} + q\vec{y} = \vec{a} \text{ and } \vec{x} \times \vec{y} = \vec{b}. \quad (\text{Nagpur University, Winter 2004})$$

Solution. The given equations are

$$p\vec{x} + q\vec{y} = \vec{a} \quad \dots(1)$$

$$\vec{x} \times \vec{y} = \vec{b} \quad \dots(2)$$

Multiplying equation (1) vectorially by \vec{x} , we get

$$\vec{x} \times (p\vec{x} + q\vec{y}) = \vec{x} \times \vec{a}$$

$$p(\vec{x} \times \vec{x}) + q(\vec{x} \times \vec{y}) = \vec{x} \times \vec{a}$$

$$q(\vec{x} \times \vec{y}) = \vec{x} \times \vec{a},$$

$$\vec{x} \times \vec{a} = q\vec{b},$$

$$\text{as } \vec{x} \times \vec{x} = 0$$

$$[\text{From (2) } \vec{x} \times \vec{y} = \vec{b}] \quad \dots(3)$$

Multiplying (3) vectorially by \vec{a} , we have

$$\vec{a} \times (\vec{x} \times \vec{a}) = \vec{a} \times q\vec{b}$$

$$(\vec{a} \cdot \vec{a})\vec{x} - (\vec{a} \cdot \vec{x})\vec{a} = q(\vec{a} \times \vec{b})$$

$$a^2 \vec{x} - (\vec{a} \cdot \vec{x})\vec{a} = q(\vec{a} \times \vec{b}) \Rightarrow a^2 \vec{x} = (\vec{a} \cdot \vec{x})\vec{a} + q(\vec{a} \times \vec{b})$$

$$\vec{x} = \frac{(\vec{a} \cdot \vec{x})\vec{a}}{a^2} + \frac{q(\vec{a} \times \vec{b})}{a^2}$$

Vectors

$$\vec{x} = \lambda \vec{a} + \frac{q(\vec{a} \times \vec{b})}{a^2} \quad \text{where } \lambda = \frac{\vec{a} \cdot \vec{x}}{a^2}$$

Substituting the value of \vec{x} in (1), we get $p \left\{ \lambda \vec{a} + \frac{q(\vec{a} \times \vec{b})}{a^2} \right\} + q \vec{y} = \vec{a}$

$$\vec{y} = \vec{a} - p \left\{ \lambda \vec{a} + \frac{q(\vec{a} \times \vec{b})}{a^2} \right\}$$

$$\vec{y} = \frac{(1 - p\lambda)\vec{a}}{q} - \frac{p(\vec{a} \times \vec{b})}{a^2}$$

Ans.

EXERCISE 5.3

1. Show that $\vec{a} \times (\vec{b} \times \vec{a}) = (\vec{a} \times \vec{b}) \times \vec{a}$

2. Write the correct answer

(a) $(\vec{A} \times \vec{B}) \times \vec{C}$ lies in the plane of

- (i) \vec{A} and \vec{B} (ii) \vec{B} and \vec{C} (iii) \vec{C} and \vec{A}

Ans. (ii)

(b) The value of $\vec{a} \cdot (\vec{b} + \vec{c}) \times (\vec{a} + \vec{b} + \vec{c})$ is

- (i) Zero (ii) $[\vec{a}, \vec{b}, \vec{c}] + [\vec{b}, \vec{c}, \vec{a}]$ (iii) $[\vec{a}, \vec{b}, \vec{c}]$ (iv) None of these

Ans. (ii)

SCALAR PRODUCT OF FOUR VECTORS

Prove the identity

$$(\vec{a} \times \vec{b}) \cdot (\vec{c} \times \vec{d}) = (\vec{a} \cdot \vec{c})(\vec{b} \cdot \vec{d}) - (\vec{a} \cdot \vec{d})(\vec{b} \cdot \vec{c})$$

Proof. $(\vec{a} \times \vec{b}) \cdot (\vec{c} \times \vec{d}) = (\vec{a} \times \vec{b}) \cdot \vec{r}$

$$= \vec{a} \cdot (\vec{b} \times \vec{r}) \text{ dot and cross can be interchanged. Put } \vec{c} \times \vec{d} = \vec{r}$$

$$= \vec{a} \cdot [\vec{b} \times (\vec{c} \times \vec{d})] = \vec{a} \cdot [(\vec{b} \cdot \vec{d})\vec{c} - (\vec{b} \cdot \vec{c})\vec{d}]$$

$$= (\vec{a} \cdot \vec{c})(\vec{b} \cdot \vec{d}) - (\vec{a} \cdot \vec{d})(\vec{b} \cdot \vec{c})$$

$$= \begin{vmatrix} \vec{a} \cdot \vec{c} & \vec{a} \cdot \vec{d} \\ \vec{b} \cdot \vec{c} & \vec{b} \cdot \vec{d} \end{vmatrix}$$

Proved.

EXERCISE 5.4

b If $\vec{a} = 2\vec{i} + 3\vec{j} - \vec{k}$, $\vec{b} = -\vec{i} + 2\vec{j} - 4\vec{k}$, $\vec{c} = \vec{i} + \vec{j} + \vec{k}$, find $(\vec{a} \times \vec{b}) \cdot (\vec{a} \times \vec{c})$.

Ans. -74

c Prove that $(\vec{a} \times \vec{b}) \cdot (\vec{a} \times \vec{c}) = a^2(\vec{b} \cdot \vec{c}) - (\vec{a} \cdot \vec{b})(\vec{a} \cdot \vec{c})$.

VECTOR PRODUCT OF FOUR VECTORS

Let $\vec{a}, \vec{b}, \vec{c}$ and \vec{d} be four vectors then their vector product is written as

$$(\vec{a} \times \vec{b}) \times (\vec{c} \times \vec{d})$$

Now, $(\vec{a} \times \vec{b}) \times (\vec{c} \times \vec{d}) = \vec{r} \times (\vec{c} \times \vec{d})$

[Put $\vec{a} \times \vec{b} = \vec{r}$]

$$= (\vec{r} \cdot \vec{d})\vec{c} - (\vec{r} \cdot \vec{c})\vec{d}$$

$$\begin{aligned}
 &= [(a \times b) \cdot d] c - [(a \times b) \cdot c] d \\
 &= [a \ b \ d] c - [a \ b \ c] d
 \end{aligned}$$

$\therefore (a \times b) \times (c \times d)$ lies in the plane of c and d(1)

Again, $(a \times b) \times (c \times d) = (a \times b) \times s$ [Put $c \times d = s$]

$$\begin{aligned}
 &= -s \times (a \times b) = -(s \cdot b) a + (s \cdot a) b \\
 &= -[(c \times d) \cdot b] a + [(c \times d) \cdot a] b = -[(b \ c \ d) a + [a \ c \ d] b
 \end{aligned}$$

$\therefore (a \times b) \times (c \times d)$ lies in the plane of a and b(2)

Geometrical interpretation : From (1) and (2) we conclude that $(a \times b) \times (c \times d)$ is a vector parallel to the line of intersection of the plane containing a, b and plane containing c, d .

Example 11. Show that

$$(B \times C) \times (A \times D) + (C \times A) \times (B \times D) + (A \times B) \times (C \times D) = -2 (A \ B \ C) D$$

Solution. L.H.S. = $(B \times C) \times (A \times D) + (C \times A) \times (B \times D) + (A \times B) \times (C \times D)$

$$\begin{aligned}
 &= [(B \ C \ D) A - (B \ C \ A) D] + [(C \ A \ D) B - (C \ A \ B) D] + [(-B \ C \ D) A + (A \ C \ D) B] \\
 &= (B \ C \ D) A - (B \ C \ D) A + (C \ A \ D) B + (A \ C \ D) B - (B \ C \ A) D - (C \ A \ B) D \\
 &= -(A \ C \ D) B + (A \ C \ D) B - (A \ B \ C) D - (A \ B \ C) D \\
 &= -2 (A \ B \ C) D = \text{R.H.S.}
 \end{aligned}$$

Proved.

EXERCISE 5.5

Show that:

1. $(b \times c) \times (c \times a) = c (a \cdot b \cdot c)$ when $(a \ b \ c)$ stands for scalar triple product.
2. $[b \times c, c \times a, a \times b] = [a \ b \ c]^2$
3. $d [a \times \{b \times (c \times d)\}] = [(b \cdot d) a \cdot (c \times d)]$
4. $a [a \times \{a \times (a \times b)\}] = a^2 (b \times a)$
5. $[(a \times b) \times (a \times c)] \cdot d = (a \cdot d) [a \ b \ c]$
6. $2a^2 = |a \times i|^2 + |a \times j|^2 + |a \times k|^2$
7. $a \times b = [(i \times a) \cdot b] i + [(j \times a) \cdot b] j + [(k \times a) \cdot b] k$
8. $p \times [(a \times q) \times (b \times r)] + q \times [(a \times r) \times (b \times p)] + r \times [(a \times p) \times (b \times q)] = 0$

Vectors

VECTOR FUNCTION

If vector r is a function of a scalar variable t , then we write

$$\vec{r} = \vec{r}(t)$$

If a particle is moving along a curved path then the position vector \vec{r} of the particle is a function of t . If the component of $f(t)$ along x -axis, y -axis, z -axis are $f_1(t), f_2(t), f_3(t)$ respectively. Then,

$$\vec{f}(t) = f_1(t)\hat{i} + f_2(t)\hat{j} + f_3(t)\hat{k}$$

DIFFERENTIATION OF VECTORS

Let O be the origin and P be the position of a moving particle at time t .

Let

$$\vec{OP} = \vec{r}$$

Let Q be the position of the particle at the time $t + \delta t$ and

the position vector of Q is $\vec{OQ} = \vec{r} + \delta\vec{r}$

$$\begin{aligned} \vec{PQ} &= \vec{OQ} - \vec{OP} \\ &= (\vec{r} + \delta\vec{r}) - \vec{r} = \delta\vec{r} \end{aligned}$$

$\frac{\delta\vec{r}}{\delta t}$ is a vector. As $\delta t \rightarrow 0$, Q tends to P and the chord becomes the tangent at P .

We define $\frac{d\vec{r}}{dt} = \lim_{\delta t \rightarrow 0} \frac{\delta\vec{r}}{\delta t}$, then

$\frac{d\vec{r}}{dt}$ is a vector in the direction of the tangent at P .

$\frac{d\vec{r}}{dt}$ is also called the differential coefficient of \vec{r} with respect to ' t '.

Similarly, $\frac{d^2\vec{r}}{dt^2}$ is the second order derivative of \vec{r} .

$\frac{d\vec{r}}{dt}$ gives the velocity of the particle at P , which is along the tangent to its path. Also $\frac{d^2\vec{r}}{dt^2}$ gives the acceleration of the particle at P .

FORMULAE OF DIFFERENTIATION

- (i) $\frac{d}{dt}(\vec{F} + \vec{G}) = \frac{d\vec{F}}{dt} + \frac{d\vec{G}}{dt}$ (ii) $\frac{d}{dt}(F\phi) = \frac{d\vec{F}}{dt}\phi + F\frac{d\phi}{dt}$ (U.P. I semester, Dec. 2005)
- (iii) $\frac{d}{dt}(F \cdot \vec{G}) = F \cdot \frac{d\vec{G}}{dt} + \frac{dF}{dt} \cdot \vec{G}$ (iv) $\frac{d}{dt}(F \times \vec{G}) = F \times \frac{d\vec{G}}{dt} + \frac{dF}{dt} \times \vec{G}$
- (v) $\frac{d}{dt}[\vec{a} \cdot \vec{b} \times \vec{c}] = \left[\frac{d\vec{a}}{dt} \cdot \vec{b} \times \vec{c} \right] + \left[\vec{a} \cdot \frac{d\vec{b}}{dt} \times \vec{c} \right] + \left[\vec{a} \cdot \vec{b} \times \frac{d\vec{c}}{dt} \right]$
- (vi) $\frac{d}{dt}[\vec{a} \times (\vec{b} \times \vec{c})] = \frac{d\vec{a}}{dt} \times (\vec{b} \times \vec{c}) + \vec{a} \times \left(\frac{d\vec{b}}{dt} \times \vec{c} + \vec{b} \times \frac{d\vec{c}}{dt} \right)$

The order of the functions \vec{F}, \vec{G} is not to be changed.

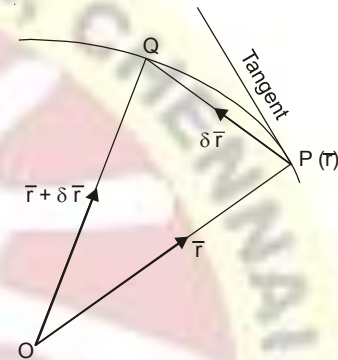

Vectors

Example 12. A particle moves along the curve $\vec{r} = (t^3 - 4t)\hat{i} + (t^2 + 4t)\hat{j} + (8t^2 - 3t^3)\hat{k}$, where t is the time. Find the magnitude of the tangential components of its acceleration at $t = 2$.

(Nagpur University, Summer 2005)

Solution. We have, $\vec{r} = (t^3 - 4t)\hat{i} + (t^2 + 4t)\hat{j} + (8t^2 - 3t^3)\hat{k}$
 Velocity = $\frac{d\vec{r}}{dt} = (3t^2 - 4)\hat{i} + (2t + 4)\hat{j} + (16t - 9t^2)\hat{k}$

At $t = 2$, Velocity = $8\hat{i} + 8\hat{j} - 4\hat{k}$

Acceleration = $\vec{a} = \frac{d^2\vec{r}}{dt^2} = 6t\hat{i} + 2\hat{j} + (16 - 18t)\hat{k}$
 At $t = 2$ $\vec{a} = 12\hat{i} + 2\hat{j} - 20\hat{k}$

The direction of velocity is along tangent.

So the tangent vector is velocity.

Unit tangent vector, $\hat{T} = \frac{\vec{v}}{|\vec{v}|} = \frac{8\hat{i} + 8\hat{j} - 4\hat{k}}{\sqrt{64 + 64 + 16}} = \frac{8\hat{i} + 8\hat{j} - 4\hat{k}}{12} = \frac{2\hat{i} + 2\hat{j} - \hat{k}}{3}$

Tangential component of acceleration, $a_t = \vec{a} \cdot \hat{T}$
 $= (12\hat{i} + 2\hat{j} - 20\hat{k}) \cdot \frac{2\hat{i} + 2\hat{j} - \hat{k}}{3} = \frac{24 + 4 + 20}{3} = \frac{48}{3} = 16$ Ans.

Example 13. If $\frac{d\vec{a}}{dt} = \vec{u} \times \vec{a}$ and $\frac{d\vec{b}}{dt} = \vec{u} \times \vec{b}$ then prove that $\frac{d}{dt}[\vec{a} \times \vec{b}] = \vec{u} \times (\vec{a} \times \vec{b})$

(M.U. 2009)

Solution. We have,

$$\begin{aligned} \frac{d}{dt}[\vec{a} \times \vec{b}] &= \vec{a} \times \frac{d\vec{b}}{dt} + \frac{d\vec{a}}{dt} \times \vec{b} = \vec{a} \times (\vec{u} \times \vec{b}) + (\vec{u} \times \vec{a}) \times \vec{b} \\ &= \vec{a} \times (\vec{u} \times \vec{b}) - \vec{b} \times (\vec{u} \times \vec{a}) \\ &= (\vec{a} \cdot \vec{b})\vec{u} - (\vec{a} \cdot \vec{u})\vec{b} - [(\vec{b} \cdot \vec{a})\vec{u} - (\vec{b} \cdot \vec{u})\vec{a}] \\ &= (\vec{a} \cdot \vec{b})\vec{u} - (\vec{u} \cdot \vec{a})\vec{b} - (\vec{a} \cdot \vec{b})\vec{u} + (\vec{u} \cdot \vec{b})\vec{a} \\ &= (\vec{u} \cdot \vec{b})\vec{a} - (\vec{u} \cdot \vec{a})\vec{b} \\ &= \vec{u} \times (\vec{a} \times \vec{b}) \end{aligned}$$

(Vector triple product)

Proved.

Example 14. Find the angle between the surface $x^2 + y^2 + z^2 = 9$ and $z = x^2 + y^2 - 3$ at $(2, -1, 2)$. (M.D.U. Dec. 2009)

Solution. Here, we have

$$x^2 + y^2 + z^2 = 9 \quad \dots(1)$$

$$z = x^2 + y^2 - 3 \quad \dots(2)$$

$$\text{Normal to (1)} \eta_1 = \nabla(x^2 + y^2 + z^2 - 9) = \left(\hat{i} \frac{\partial}{\partial x} + \hat{j} \frac{\partial}{\partial y} + \hat{k} \frac{\partial}{\partial z} \right) (x^2 + y^2 + z^2 - 9) = 2x\hat{i} + 2y\hat{j} + 2z\hat{k}$$

$$\text{Normal to (1) at } (2, -1, 2), \eta_1 = 4\hat{i} - 2\hat{j} + 4\hat{k} \quad \dots(3)$$

Vectors

Normal to (2),
$$\eta_2 = \nabla(z - x^2 - y^2 + 3)$$

$$= \left(\hat{i} \frac{\partial}{\partial x} + \hat{j} \frac{\partial}{\partial y} + \hat{k} \frac{\partial}{\partial z} \right) (z - x^2 - y^2 + 3) = -2x \hat{i} - 2y \hat{j} + \hat{k}$$

Normal to (2) at (2, -1, 2), $\eta_2 = -4\hat{i} + 2\hat{j} + \hat{k}$... (4)

$\eta_1 \cdot \eta_2 = |\eta_1| |\eta_2| \cos \theta$

$$\cos \theta = \frac{\eta_1 \cdot \eta_2}{|\eta_1| |\eta_2|} = \frac{(4\hat{i} - 2\hat{j} + 4\hat{k}) \cdot (-4\hat{i} + 2\hat{j} + \hat{k})}{|4\hat{i} - 2\hat{j} + 4\hat{k}| | -4\hat{i} + 2\hat{j} + \hat{k} |} = \frac{-16 - 4 + 4}{\sqrt{16+4+16} \sqrt{16+4+1}}$$

$$= \frac{-16}{6\sqrt{21}} = \frac{-8}{3\sqrt{21}}$$

$$\theta = \cos^{-1} \left(\frac{-8}{3\sqrt{21}} \right)$$

Hence the angle between (1) and (2) $\cos^{-1} \left(\frac{-8}{3\sqrt{21}} \right)$ **Ans**

EXERCISE 5.6

1. The coordinates of a moving particle are given by $x = 4t - \frac{t^2}{2}$ and $y = 3 + 6t - \frac{t^3}{6}$. Find the velocity and acceleration of the particle when $t = 2$ secs. **Ans.** 4.47, 2.24

2. A particle moves along the curve $x = 2t^2$, $y = t^2 - 4t$ and $z = 3t - 5$ where t is the time. Find the components of its velocity and acceleration at time $t = 1$, in the direction $\hat{i} - 3\hat{j} + 2\hat{k}$. **Ans.** $\frac{7}{\sqrt{14}}$, $-\frac{14}{\sqrt{14}}$
(Nagpur, Summer 2001)

3. Find the unit tangent and unit normal vector at $t = 2$ on the curve $x = t^2 - 1$, $y = 4t - 3$, $z = 2t^2 - 6t$ where t is any variable. **Ans.** $\frac{1}{3}(2\hat{i} + 2\hat{j} + \hat{k})$, $\frac{1}{3\sqrt{5}}(2\hat{i} + 2\hat{k})$

4. Prove that $\frac{d}{dt}(F \times G) = F \times \frac{dG}{dt} + \frac{dF}{dt} \times G$

5. Find the angle between the tangents to the curve $r = t^2\hat{i} + 2t\hat{j} - t^3\hat{k}$, at the points $t = \pm 1$. **Ans.** $\cos^{-1} \left(\frac{9}{17} \right)$

6. If the surface $5x^2 - 2byz = 9x$ be orthogonal to the surface $4x^2y + z^3 = 4$ at the point (1, -1, 2) then b is equal to
 (a) 0 (b) 1 (c) 2 (d) 3 *(AMIETE, Dec. 2009)* **Ans.** (b)

SCALAR AND VECTOR POINT FUNCTIONS

Point function. A variable quantity whose value at any point in a region of space depends upon the position of the point, is called a *point function*. There are two types of point functions.

(i) **Scalar point function.** If to each point $P(x, y, z)$ of a region R in space there corresponds a unique scalar $f(P)$, then f is called a scalar point function. For example, the temperature distribution in a heated body, density of a body and potential due to gravity are the examples of a scalar point function.

(ii) **Vector point function.** If to each point $P(x, y, z)$ of a region R in space there corresponds a unique vector $f(P)$, then f is called a *vector point function*. The velocity of a moving fluid, gravitational force are the examples of vector point function.

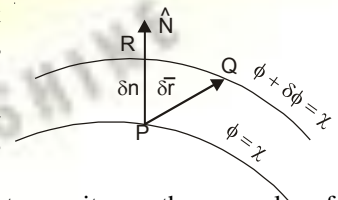

(U.P., I Semester, Winter 2000)

Vector Differential Operator Del i.e. ∇

The vector differential operator Del is denoted by ∇ . It is defined as

$$\nabla = i \frac{\partial}{\partial x} + j \frac{\partial}{\partial y} + k \frac{\partial}{\partial z}$$

GRADIENT OF A SCALAR FUNCTION

If $\phi(x, y, z)$ be a scalar function then $i \frac{\partial \phi}{\partial x} + j \frac{\partial \phi}{\partial y} + k \frac{\partial \phi}{\partial z}$ is called the gradient of the scalar function ϕ .

And is denoted by $\text{grad } \phi$.

Thus,

$$\text{grad } \phi = i \frac{\partial \phi}{\partial x} + j \frac{\partial \phi}{\partial y} + k \frac{\partial \phi}{\partial z}$$

$$\text{grad } \phi = \left(i \frac{\partial}{\partial x} + j \frac{\partial}{\partial y} + k \frac{\partial}{\partial z} \right) \phi(x, y, z)$$

$$\text{grad } \phi = \nabla \phi \quad (\nabla \text{ is read del or nebla})$$

GEOMETRICAL MEANING OF GRADIENT, NORMAL

(U.P. Ist Semester, Dec 2006)

If a surface $\phi(x, y, z) = c$ passes through a point P . The value of the function at each point on the surface is the same as at P . Then such a surface is called a *level surface* through P . For example, If $\phi(x, y, z)$ represents potential at the point P , then *equipotential surface* $\phi(x, y, z) = c$ is a *level surface*.

Two level surfaces can not intersect.

Let the level surface pass through the point P at which the value of the function is ϕ . Consider another level surface passing through Q , where the value of the function is $\phi + d\phi$.

Let \vec{r} and $\vec{r} + \delta\vec{r}$ be the position vector of P and Q then $\overrightarrow{PQ} = \delta\vec{r}$

$$\begin{aligned} \nabla\phi \cdot d\vec{r} &= \left(i \frac{\partial \phi}{\partial x} + j \frac{\partial \phi}{\partial y} + k \frac{\partial \phi}{\partial z} \right) \cdot (i dx + j dy + k dz) \\ &= \frac{\partial \phi}{\partial x} dx + \frac{\partial \phi}{\partial y} dy + \frac{\partial \phi}{\partial z} dz = d\phi \end{aligned} \quad \dots(1)$$

If Q lies on the level surface of P , then $d\phi = 0$

Equation (1) becomes $\nabla\phi \cdot d\vec{r} = 0$. Then $\nabla\phi$ is \perp to $d\vec{r}$ (tangent).

Hence, $\nabla\phi$ is **normal** to the surface $\phi(x, y, z) = c$

Let $\nabla\phi = |\nabla\phi| N$, where N is a unit normal vector. Let δn be the perpendicular distance between two level surfaces through P and R . Then the rate of change of ϕ in the direction of the

normal to the surface through P is $\frac{\partial \phi}{\partial n}$.

$$\begin{aligned} \frac{d\phi}{dn} &= \lim_{\delta n \rightarrow 0} \frac{\delta\phi}{\delta n} = \lim_{\delta n \rightarrow 0} \frac{\nabla\phi \cdot d\vec{r}}{\delta n} \\ &= \lim_{\delta n \rightarrow 0} \frac{|\nabla\phi| N \cdot d\vec{r}}{\delta n} \\ &= \lim_{\delta n \rightarrow 0} \frac{|\nabla\phi| \delta n}{\delta n} = |\nabla\phi| \end{aligned} \quad \left\{ \begin{array}{l} \vec{N} \cdot \vec{\delta r} = |N| |\delta r| \cos \theta \\ \delta n = |\delta r| \cos \theta = \delta n \end{array} \right.$$

Vectors

$$\therefore |\nabla\phi| = \frac{\partial\phi}{\partial n}$$

Hence, gradient ϕ is a vector normal to the surface $\phi = c$ and has a magnitude equal to the rate of change of ϕ along this normal.

NORMAL AND DIRECTIONAL DERIVATIVE

(i) **Normal.** If $\phi(x, y, z) = c$ represents a family of surfaces for different values of the constant c . On differentiating ϕ , we get $d\phi = 0$

But
$$d\phi = \nabla\phi \cdot d\vec{r} \quad \text{so} \quad \nabla\phi \cdot d\vec{r} = 0$$

The scalar product of two vectors $\nabla\phi$ and $d\vec{r}$ being zero, $\nabla\phi$ and $d\vec{r}$ are perpendicular to each other. $d\vec{r}$ is in the direction of tangent to the given surface.

Thus $\nabla\phi$ is a vector *normal* to the surface $\phi(x, y, z) = c$.

(ii) **Directional derivative.** The component of $\nabla\phi$ in the direction of a vector \vec{d} is equal to $\nabla\phi \cdot \vec{d}$ and is called the directional derivative of ϕ in the direction of \vec{d} .

$$\frac{\partial\phi}{\partial r} = \lim_{\delta r \rightarrow 0} \frac{\delta\phi}{\delta r} \quad \text{where, } \delta r = PQ$$

$\frac{\partial\phi}{\partial r}$ is called the *directional derivative* of ϕ at P in the direction of PQ .

Let a unit vector along PQ be \hat{N}' .

$$\frac{\delta n}{\delta r} = \cos \theta \Rightarrow \delta r = \frac{\delta n}{\cos \theta} = \frac{\delta n}{\hat{N} \cdot \hat{N}'} \quad \dots(1)$$

Now
$$\frac{\partial\phi}{\partial r} = \lim_{\delta r \rightarrow 0} \left[\frac{\delta\phi}{\delta r} \right] = \hat{N} \cdot \hat{N}' \frac{\partial\phi}{\partial n} \quad \left[\begin{array}{l} \text{From (1), } \delta r = \frac{\delta n}{\hat{N} \cdot \hat{N}'} \\ \left[\frac{\delta\phi}{\delta r} \right] = \frac{\delta\phi}{\delta n} \cdot \frac{\delta n}{\delta r} \end{array} \right]$$

$$= \hat{N} \cdot \hat{N}' |\nabla\phi| = \hat{N}' \cdot \nabla\phi \quad (\hat{N} \cdot \nabla\phi = |\nabla\phi|)$$

Hence, $\frac{\partial\phi}{\partial r}$, directional derivative is the component of $\nabla\phi$ in the direction \hat{N}' .

$$\frac{\partial\phi}{\partial r} = \hat{N}' \cdot \nabla\phi = |\nabla\phi| \cos \theta \leq |\nabla\phi|$$

Hence, $\nabla\phi$ is the maximum rate of change of ϕ .

Example 15. For the vector field (i) $\vec{A} = m\hat{i}$ and (ii) $\vec{A} = m\vec{r}$. Find $\nabla \cdot \vec{A}$ and $\nabla \times \vec{A}$. Draw the sketch in each case. (Gujarat, I Semester, Jan. 2009)

Solution. (i) Vector $\vec{A} = m\hat{i}$ is represented in the figure (i).

(ii) $\vec{A} = m\vec{r}$ is represented in the figure (ii). $\hat{i} + \hat{j} + \hat{k} = 1 + 1 + 1 = 3$

(iii)
$$\nabla \cdot \vec{A} = \left(i \frac{\partial}{\partial x} + j \frac{\partial}{\partial y} + k \frac{\partial}{\partial z} \right) \cdot (x\hat{i} + y\hat{j} + z\hat{k})$$

$\nabla \cdot \vec{A} = 3$ is represented on the number line at 3.

(iv)
$$\nabla \times \vec{A} = \left(i \frac{\partial}{\partial x} + j \frac{\partial}{\partial y} + k \frac{\partial}{\partial z} \right) \times (x\hat{i} + y\hat{j} + z\hat{k})$$

$$= \begin{vmatrix} \hat{i} & \hat{j} & \hat{k} \\ \frac{\partial}{\partial x} & \frac{\partial}{\partial y} & \frac{\partial}{\partial z} \\ x & y & z \end{vmatrix} = 0$$

are represented in the adjoining figure.

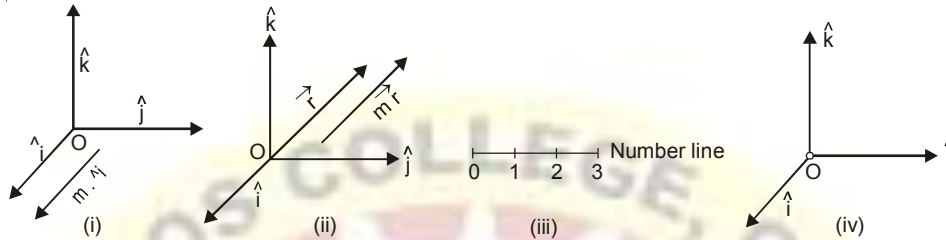

Example 16. If $\phi = 3x^2y - y^3z^2$; find $\text{grad } \phi$ at the point $(1, -2, -1)$.

(AMIETE, June 2009, U.P., I Semester, Dec. 2006)

Solution.

$$\begin{aligned} \text{grad } \phi &= \nabla \phi \\ &= \left(\hat{i} \frac{\partial}{\partial x} + \hat{j} \frac{\partial}{\partial y} + \hat{k} \frac{\partial}{\partial z} \right) (3x^2y - y^3z^2) \\ &= \hat{i} \frac{\partial}{\partial x} (3x^2y - y^3z^2) + \hat{j} \frac{\partial}{\partial y} (3x^2y - y^3z^2) + \hat{k} \frac{\partial}{\partial z} (3x^2y - y^3z^2) \\ &= \hat{i} (6xy) + \hat{j} (3x^2 - 3y^3z) + \hat{k} (-2y^3z) \end{aligned}$$

$$\begin{aligned} \text{grad } \phi \text{ at } (1, -2, -1) &= \hat{i} (6) (1) (-2) + \hat{j} [(3) (1) - 3(4) (1)] + \hat{k} (-2)(-8) (-1) \\ &= -12\hat{i} - 9\hat{j} - 16\hat{k} \end{aligned}$$

Ans.

Example 17. If $u = x + y + z$, $v = x^2 + y^2 + z^2$, $w = yz + zx + xy$ prove that $\text{grad } u$, $\text{grad } v$ and $\text{grad } w$ are coplanar vectors.

[U.P., I Semester, 2001]

Solution. We have,

$$\begin{aligned} \text{grad } u &= \left(\hat{i} \frac{\partial}{\partial x} + \hat{j} \frac{\partial}{\partial y} + \hat{k} \frac{\partial}{\partial z} \right) (x + y + z) = \hat{i} + \hat{j} + \hat{k} \\ \text{grad } v &= \left(\hat{i} \frac{\partial}{\partial x} + \hat{j} \frac{\partial}{\partial y} + \hat{k} \frac{\partial}{\partial z} \right) (x^2 + y^2 + z^2) = 2x\hat{i} + 2y\hat{j} + 2z\hat{k} \\ \text{grad } w &= \left(\hat{i} \frac{\partial}{\partial x} + \hat{j} \frac{\partial}{\partial y} + \hat{k} \frac{\partial}{\partial z} \right) (yz + zx + xy) = \hat{i}(z + y) + \hat{j}(z + x) + \hat{k}(y + x) \end{aligned}$$

[For vectors to be coplanar, their scalar triple product is 0]

$$\text{Now, } \text{grad } u \cdot (\text{grad } v \times \text{grad } w) = \begin{vmatrix} 1 & 1 & 1 \\ 2x & 2y & 2z \\ z + y & z + x & y + x \end{vmatrix} = 2 \begin{vmatrix} 1 & 1 & 1 \\ x & y & z \\ z + y & z + x & y + x \end{vmatrix}$$

$$= 2 \begin{vmatrix} 1 & 1 & 1 \\ x + y + z & x + y + z & x + y + z \\ z + y & z + x & y + x \end{vmatrix} \quad \text{[Applying } R_2 \rightarrow R_2 + R_3]$$

$$= 2(x + y + z) \begin{vmatrix} 1 & 1 & 1 \\ 1 & 1 & 1 \\ y + z & z + x & x + y \end{vmatrix} = 0$$

Vectors

Since the scalar product of grad u , grad v and grad w are zero, hence these vectors are coplanar vectors. **Proved.**

Example 18. Find the directional derivative of $x^2y^2z^2$ at the point $(1, 1, -1)$ in the direction of the tangent to the curve $x = e^t$, $y = \sin 2t + 1$, $z = 1 - \cos t$ at $t = 0$.

(Nagpur University, Summer 2005)

Solution. Let $\phi = x^2 y^2 z^2$

Directional Derivative of ϕ

$$= \nabla\phi = \left(i \frac{\partial}{\partial x} + j \frac{\partial}{\partial y} + k \frac{\partial}{\partial z} \right) (x^2 y^2 z^2)$$

$$\nabla\phi = 2xy z^2 \hat{i} + 2yx^2 z^2 \hat{j} + 2zx^2 y^2 \hat{k}$$

Directional Derivative of ϕ at $(1, 1, -1)$

$$= 2(1)(1)^2(-1)^2 \hat{i} + 2(1)(1)^2(-1)^2 \hat{j} + 2(-1)(1)^2(1)^2 \hat{k}$$

$$= 2 \hat{i} + 2 \hat{j} - 2 \hat{k} \quad \dots(1)$$

$$\vec{r} = x \hat{i} + y \hat{j} + z \hat{k} = e^t \hat{i} + (\sin 2t + 1) \hat{j} + (1 - \cos t) \hat{k}$$

Tangent vector, $\vec{T} = \frac{d\vec{r}}{dt} = e^t \hat{i} + 2 \cos 2t \hat{j} + \sin t \hat{k}$

$$\text{Tangent(at } t = 0) = e^0 \hat{i} + 2(\cos 0) \hat{j} + (\sin 0) \hat{k} = \hat{i} + 2 \hat{j} \quad \dots(2)$$

$$\text{Required directional derivative along tangent} = (2 \hat{i} + 2 \hat{j} - 2 \hat{k}) \cdot \frac{(\hat{i} + 2 \hat{j})}{\sqrt{1+4}}$$

[From (1), (2)]

$$= \frac{2+4+0}{\sqrt{5}} = \frac{6}{\sqrt{5}}$$

Ans.

Example 19. Find the unit normal to the surface $xy^3z^2 = 4$ at $(-1, -1, 2)$. (M.U. 2008)

Solution. Let $\phi(x, y, z) = xy^3z^2 = 4$

We know that $\nabla\phi$ is the vector normal to the surface $\phi(x, y, z) = c$.

$$\text{Normal vector} = \nabla\phi = i \frac{\partial \phi}{\partial x} + j \frac{\partial \phi}{\partial y} + k \frac{\partial \phi}{\partial z}$$

$$\text{Now} \quad = i \frac{\partial}{\partial x} (xy^3z^2) + j \frac{\partial}{\partial y} (xy^3z^2) + k \frac{\partial}{\partial z} (xy^3z^2)$$

$$\Rightarrow \quad \text{Normal vector} = y^3 z^2 i + 3xy^2 z^2 j + 2xy^3 z k$$

$$\text{Normal vector at } (-1, -1, 2) = -4 \hat{i} - 12 \hat{j} + 4 \hat{k}$$

Unit vector normal to the surface at $(-1, -1, 2)$.

$$= \frac{\nabla\phi}{|\nabla\phi|} = \frac{-4 \hat{i} - 12 \hat{j} + 4 \hat{k}}{\sqrt{16+144+16}} = -\frac{1}{\sqrt{11}} (\hat{i} + 3 \hat{j} - \hat{k})$$

Ans.

Example 20. Find the rate of change of $\phi = xyz$ in the direction normal to the surface $x^2y + y^2x + yz^2 = 3$ at the point $(1, 1, 1)$. (Nagpur University, Summer 2001)

Solution. Rate of change of $\phi = \Delta \phi$

$$= \left(i \frac{\partial}{\partial x} + j \frac{\partial}{\partial y} + k \frac{\partial}{\partial z} \right) (xyz) = i yz + j xz + k xy$$

Rate of change of ϕ at $(1, 1, 1) = (\hat{i} + \hat{j} + \hat{k})$

Normal to the surface $\Psi = x^2y + y^2x + yz^2 - 3$ is given as -

$$\begin{aligned}\nabla\Psi &= \left(\hat{i} \frac{\partial}{\partial x} + \hat{j} \frac{\partial}{\partial y} + \hat{k} \frac{\partial}{\partial z} \right) (x^2y + y^2x + yz^2 - 3) \\ &= \hat{i}(2xy + y^2) + \hat{j}(x^2 + 2xy + z^2) + \hat{k}2yz \\ (\nabla\Psi)_{(1,1,1)} &= 3\hat{i} + 4\hat{j} + 2\hat{k} \\ \text{Unit normal} &= \frac{3\hat{i} + 4\hat{j} + 2\hat{k}}{\sqrt{9+16+4}}\end{aligned}$$

Required rate of change of $\phi = (\hat{i} + \hat{j} + \hat{k}) \cdot \frac{(3\hat{i} + 4\hat{j} + 2\hat{k})}{\sqrt{9+16+4}} = \frac{3+4+2}{\sqrt{29}} = \frac{9}{\sqrt{29}}$ **Ans.**

Example 21. Find the constants m and n such that the surface $mx^2 - 2nyz = (m+4)x$ will be orthogonal to the surface $4x^2y + z^3 = 4$ at the point $(1, -1, 2)$.

(M.D.U. Dec. 2009, Nagpur University, Summer 2002)

Solution. The point $P(1, -1, 2)$ lies on both surfaces. As this point lies in

$$mx^2 - 2nyz = (m+4)x, \text{ so we have}$$

$$m - 2n(-2) = (m+4)$$

$$\Rightarrow m + 4n = m + 4 \Rightarrow n = 1$$

\therefore

$$\text{Let } \phi_1 = mx^2 - 2yz - (m+4)x \text{ and } \phi_2 = 4x^2y + z^3 - 4$$

Normal to $\phi_1 = \nabla\phi_1$

$$\begin{aligned}& \left(\hat{i} \frac{\partial}{\partial x} + \hat{j} \frac{\partial}{\partial y} + \hat{k} \frac{\partial}{\partial z} \right) [mx^2 - 2yz - (m+4)x] \\ &= \left(\hat{i} \frac{\partial}{\partial x} + \hat{j} \frac{\partial}{\partial y} + \hat{k} \frac{\partial}{\partial z} \right) [2mx - 2y - (m+4)] \\ &= \hat{i}(2m - m - 4) - 2\hat{j} - 2y\hat{k}\end{aligned}$$

$$\text{Normal to } \phi_1 \text{ at } (1, -1, 2) = \hat{i}(2m - m - 4) - 4\hat{j} + 2\hat{k} = (m-4)\hat{i} - 4\hat{j} + 2\hat{k}$$

Normal to $\phi_2 = \nabla\phi_2$

$$\begin{aligned}& \left(\hat{i} \frac{\partial}{\partial x} + \hat{j} \frac{\partial}{\partial y} + \hat{k} \frac{\partial}{\partial z} \right) [4x^2y + z^3 - 4] \\ &= \left(\hat{i} \frac{\partial}{\partial x} + \hat{j} \frac{\partial}{\partial y} + \hat{k} \frac{\partial}{\partial z} \right) [8xy + 3z^2] = 8x\hat{j} + 4x^2\hat{i} + 6z\hat{k}\end{aligned}$$

$$\text{Normal to } \phi_2 \text{ at } (1, -1, 2) = -8\hat{i} + 4\hat{j} + 12\hat{k}$$

Since ϕ_1 and ϕ_2 are orthogonal, then normals are perpendicular to each other.

$$\nabla\phi_1 \cdot \nabla\phi_2 = 0$$

$$\Rightarrow [(m-4)\hat{i} - 4\hat{j} + 2\hat{k}] \cdot [-8\hat{i} + 4\hat{j} + 12\hat{k}] = 0$$

$$\Rightarrow -8(m-4) - 16 + 24 = 0$$

$$\Rightarrow m - 4 = -2 + 3 \Rightarrow m = 5$$

Hence $m = 5, n = 1$

Ans.

Example 22. Find the values of constants λ and μ so that the surfaces $\lambda x^2 - \mu yz = (\lambda + 2)x$, $4x^2y + z^3 = 4$ intersect orthogonally at the point $(1, -1, 2)$.

(AMIETE, II Sem., Dec. 2010, June 2009)

Solution. Here, we have

$$\lambda x^2 - \mu yz = (\lambda + 2)x \quad \dots(1)$$

$$4x^2y + z^3 = 4 \quad \dots(2)$$

Vectors

$$\begin{aligned} \text{Normal to the surface (1),} &= \nabla [\lambda x^2 - \mu yz - (\lambda + 2)x] \\ &= \left[\hat{i} \frac{\partial}{\partial x} + \hat{j} \frac{\partial}{\partial y} + \hat{k} \frac{\partial}{\partial z} \right] [\lambda x^2 - \mu yz - (\lambda + 2)x] \\ &= \hat{i} (2\lambda x - \lambda - 2) + \hat{j} (-\mu z) + \hat{k} (-\mu y) \\ \text{Normal at (1, -1, 2)} &= \hat{i} (2\lambda - \lambda - 2) - \hat{j} (-2\mu) + \hat{k} \mu \end{aligned} \quad \dots(3)$$

$$\begin{aligned} \text{Normal at the surface (2)} &= \left(\hat{i} \frac{\partial}{\partial x} + \hat{j} \frac{\partial}{\partial y} + \hat{k} \frac{\partial}{\partial z} \right) (4x^2 y + z^3 - 4) \\ &= \hat{i} (8xy) + \hat{j} (4x^2) + \hat{k} (3z^2) \end{aligned} \quad \dots(4)$$

$$\text{Normal at the point (1, -1, 2)} = -8\hat{i} + 4\hat{j} + 12\hat{k} \quad \dots(4)$$

Since (3) and (4) are orthogonal so

$$\begin{aligned} [\hat{i}(\lambda - 2) + \hat{j}(2\mu) + \hat{k}\mu] \cdot [-8\hat{i} + 4\hat{j} + 12\hat{k}] &= 0 \\ -8(\lambda - 2) + 4(2\mu) + 12\mu &= 0 \Rightarrow -8\lambda + 16 + 8\mu + 12\mu = 0 \\ -8\lambda - 20\mu + 16 &= 0 \Rightarrow 4(-2\lambda + 5\mu + 4) = 0 \\ -2\lambda + 5\mu + 4 &= 0 \Rightarrow 2\lambda - 5\mu = 4 \end{aligned} \quad \dots(5)$$

Point (1, -1, 2) will satisfy (1)

$$\therefore \lambda(1)^2 - \mu(-1)(2) = (\lambda + 2)(1) \Rightarrow \lambda + 2\mu = \lambda + 2 \Rightarrow \mu = 1$$

Putting $\mu = 1$ in (5), we get

$$2\lambda - 5 = 4 \Rightarrow \lambda = \frac{9}{2}$$

Hence $\lambda = \frac{9}{2}$ and $\mu = 1$

Ans.

Example 23. Find the angle between the surfaces $x^2 + y^2 + z^2 = 9$ and $z = x^2 + y^2 - 3$ at the point (2, -1, 2). (Nagpur University, Summer 2002)

Solution. Normal on the surface $(x^2 + y^2 + z^2 - 9 = 0)$

$$\nabla \phi = \left(\hat{i} \frac{\partial}{\partial x} + \hat{j} \frac{\partial}{\partial y} + \hat{k} \frac{\partial}{\partial z} \right) (x^2 + y^2 + z^2 - 9) = (2xi + 2y j + 2zk)$$

$$\text{Normal at the point (2, -1, 2)} = 4\hat{i} - 2\hat{j} + 4\hat{k} \quad \dots(1)$$

$$\begin{aligned} \text{Normal on the surface } (z = x^2 + y^2 - 3) &= \left(\hat{i} \frac{\partial}{\partial x} + \hat{j} \frac{\partial}{\partial y} + \hat{k} \frac{\partial}{\partial z} \right) (x^2 + y^2 - z - 3) \\ &= 2xi + 2y j - k \end{aligned}$$

$$\text{Normal at the point (2, -1, 2)} = 4\hat{i} - 2\hat{j} - \hat{k} \quad \dots(2)$$

Let θ be the angle between normals (1) and (2).

$$\begin{aligned} (4\hat{i} - 2\hat{j} + 4\hat{k}) \cdot (4\hat{i} - 2\hat{j} - \hat{k}) &= \sqrt{16 + 4 + 16} \sqrt{16 + 4 + 1} \cos \theta \\ 16 + 4 - 4 &= 6\sqrt{21} \cos \theta \Rightarrow 16 = 6\sqrt{21} \cos \theta \end{aligned}$$

Vectors

$$\Rightarrow \cos \theta = \frac{8}{3\sqrt{21}} \Rightarrow \theta = \cos^{-1} \frac{8}{3\sqrt{21}} \quad \text{Ans.}$$

Example 24. Find the directional derivative of $\frac{1}{r}$ in the direction \vec{r} where $\vec{r} = xi + yj + zk$.
(Nagpur University, Summer 2004, U.P., 1 Semester, Winter 2005, 2002)

Solution. Here, $\phi(x, y, z) = \frac{1}{r} = \frac{1}{\sqrt{x^2 + y^2 + z^2}} = (x^2 + y^2 + z^2)^{-\frac{1}{2}}$

Now $\nabla \left(\frac{1}{r} \right) = \left(i \frac{\partial}{\partial x} + j \frac{\partial}{\partial y} + k \frac{\partial}{\partial z} \right) (x^2 + y^2 + z^2)^{-\frac{1}{2}}$

$$= \frac{-\frac{1}{2}}{\partial x} (x^2 + y^2 + z^2)^{-\frac{3}{2}} i + \frac{-\frac{1}{2}}{\partial y} (x^2 + y^2 + z^2)^{-\frac{3}{2}} j + \frac{-\frac{1}{2}}{\partial z} (x^2 + y^2 + z^2)^{-\frac{3}{2}} k$$

$$= \left\{ -\frac{1}{2} (x^2 + y^2 + z^2)^{-\frac{3}{2}} 2x \right\} i + \left\{ -\frac{1}{2} (x^2 + y^2 + z^2)^{-\frac{3}{2}} 2y \right\} j + \left\{ -\frac{1}{2} (x^2 + y^2 + z^2)^{-\frac{3}{2}} 2z \right\} k$$

$$= \frac{-(xi + yj + zk)}{(x^2 + y^2 + z^2)^{3/2}} \quad \dots(1)$$

and $\hat{r} =$ unit vector in the direction of $xi + yj + zk$

$$= \frac{xi + yj + zk}{\sqrt{x^2 + y^2 + z^2}} \quad \dots(2)$$

So, the required directional derivative

$$= \nabla \phi \cdot \hat{r} = -\frac{xi + yj + zk}{(x^2 + y^2 + z^2)^{3/2}} \cdot \frac{xi + yj + zk}{(x^2 + y^2 + z^2)^{1/2}} = \frac{x^2 + y^2 + z^2}{(x^2 + y^2 + z^2)^2} \quad [\text{From (1), (2)}]$$

$$= \frac{1}{x^2 + y^2 + z^2} = \frac{1}{r^2} \quad \text{Ans.}$$

Example 25. Find the direction in which the directional derivative of $\phi(x, y) = \frac{x^2 + y^2}{xy}$ at $(1, 1)$ is zero and hence find out component of velocity of the vector $\vec{r} = (t^3 + 1)i + t^2j$ in the same direction at $t = 1$.
(Nagpur University, Winter 2000)

Solution. Directional derivative = $\nabla \phi = \left(i \frac{\partial}{\partial x} + j \frac{\partial}{\partial y} + k \frac{\partial}{\partial z} \right) \left(\frac{x^2 + y^2}{xy} \right)$

$$= \left[i \frac{\partial}{\partial x} \left(\frac{x^2 + y^2}{xy} \right) + j \frac{\partial}{\partial y} \left(\frac{x^2 + y^2}{xy} \right) \right]$$

$$= \left[i \frac{xy \cdot 2x - (x^2 + y^2)y}{x^2 y^2} + j \frac{xy \cdot 2y - x(y^2 + x^2)}{x^2 y^2} \right]$$

$$= \left[i \frac{x^2 y - y^3}{x^2 y^2} + j \frac{xy^2 - x^3}{x^2 y^2} \right]$$

Directional Derivative at $(1, 1) = i \cdot 0 + j \cdot 0 = 0$

Since $(\nabla \phi)_{(1,1)} = 0$, the directional derivative of ϕ at $(1, 1)$ is zero in any direction.

Again $\vec{r} = (t^3 + 1)i + t^2j$

Vectors

$$\text{Velocity, } \vec{v} = \frac{d\vec{r}}{dt} = 3t^2 \hat{i} + 2t \hat{j}$$

$$\text{Velocity at } t = 1 \text{ is } = 3\hat{i} + 2\hat{j}$$

The component of velocity in the same direction of velocity

$$= (3\hat{i} + 2\hat{j}) \cdot \frac{(3\hat{i} + 2\hat{j})}{\sqrt{9+4}} = \frac{9+4}{\sqrt{13}} = \sqrt{13}$$

Ans.

Example 26. Find the directional derivative of $\phi(x, y, z) = x^2 y z + 4 x z^2$ at $(1, -2, 1)$ in the direction of $2\hat{i} - \hat{j} - 2\hat{k}$. Find the greatest rate of increase of ϕ .

(Uttarakhand, I Semester, Dec. 2006)

Solution. Here, $\phi(x, y, z) = x^2 y z + 4 x z^2$

Now,

$$\begin{aligned} \nabla\phi &= \left(i \frac{\partial}{\partial x} + j \frac{\partial}{\partial y} + k \frac{\partial}{\partial z} \right) (x^2 y z + 4 x z^2) \\ &= (2xyz + 4z^2)\hat{i} + (x^2 z)\hat{j} + (x^2 y + 8xz)\hat{k} \\ \nabla\phi \text{ at } (1, -2, 1) &= \{2(1)(-2)(1) + 4(1)\}\hat{i} + \{1 \times (-2) + 1(-2)\}\hat{j} + \{8(1)(1)\}\hat{k} \\ &= (-4 + 4)\hat{i} + (-2 + 8)\hat{j} + 8\hat{k} = 6\hat{j} + 8\hat{k} \\ \hat{a} &= \text{unit vector} = \frac{2\hat{i} - \hat{j} - 2\hat{k}}{\sqrt{4+1+4}} = \frac{2\hat{i} - \hat{j} - 2\hat{k}}{3} \end{aligned}$$

Let

$$\begin{aligned} \text{So, the required directional derivative at } (1, -2, 1) &= \nabla\phi \cdot \hat{a} = (6\hat{j} + 8\hat{k}) \cdot \frac{1}{3}(2\hat{i} - \hat{j} - 2\hat{k}) = \frac{1}{3}(-1-12) = \frac{-13}{3} \end{aligned}$$

$$\begin{aligned} \text{Greatest rate of increase of } \phi &= \left| \frac{\partial \phi}{\partial s} \right| = \sqrt{1+36} \\ &= \sqrt{37} \end{aligned}$$

Ans.

Example 27. Find the directional derivative of the function $\phi = x^2 - y^2 + 2z^2$ at the point $P(1, 2, 3)$ in the direction of the line PQ where Q is the point $(5, 0, 4)$.

(AMIETE, Dec. 20010, Nagpur University, Summer 2008, U.P., I Sem., Winter 2000)

$$\begin{aligned} \text{Solution. Directional derivative} &= \nabla\phi \\ &= \left(i \frac{\partial}{\partial x} + j \frac{\partial}{\partial y} + k \frac{\partial}{\partial z} \right) (x^2 - y^2 + 2z^2) = 2xi - 2yj + 4zk \end{aligned}$$

$$\text{Directional Derivative at the point } P(1, 2, 3) = 2\hat{i} - 4\hat{j} + 12\hat{k} \quad \dots(1)$$

$$\vec{PQ} = \vec{Q} - \vec{P} = (5, 0, 4) - (1, 2, 3) = (4, -2, 1) \quad \dots(2)$$

$$\text{Directional Derivative along } PQ = (2\hat{i} - 4\hat{j} + 12\hat{k}) \cdot \frac{(4\hat{i} - 2\hat{j} + \hat{k})}{\sqrt{16+4+1}} \quad [\text{From (1) and (2)}]$$

$$= \frac{8+8+12}{\sqrt{21}} = \frac{28}{\sqrt{21}}$$

Ans.

Example 28. For the function $\phi(x, y) = \frac{x}{x^2 + y^2}$, find the magnitude of the directional derivative along a line making an angle 30° with the positive x -axis at $(0, 2)$.

(A.M.I.E.T.E., Winter 2002)

Vectors

Solution. Directional derivative = $\vec{\nabla}\phi$

$$= \left(i \frac{\partial}{\partial x} + j \frac{\partial}{\partial y} + k \frac{\partial}{\partial z} \right) \frac{x}{x^2 + y^2} = i \left(\frac{1}{x^2 + y^2} - \frac{x(2x)}{(x^2 + y^2)^2} \right) - j \frac{x(2y)}{(x^2 + y^2)^2}$$

$$= i \frac{y^2 - x^2}{(x^2 + y^2)^2} - j \frac{2xy}{(x^2 + y^2)^2}$$

Directional derivative at the point (0, 2)

$$= i \frac{4 - 0}{(0 + 4)^2} - j \frac{2(0)(2)}{(0 + 4)^2} = \frac{i}{4}$$

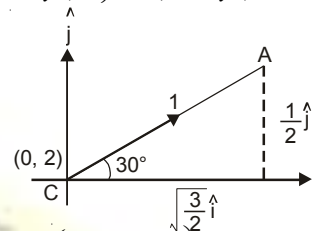

Directional derivative at the point (0, 2) in the direction \vec{CA} i.e. $\left(\frac{\sqrt{3}}{2} \hat{i} + \frac{1}{2} \hat{j} \right)$

$$= \frac{\hat{i}}{4} \cdot \left(\frac{\sqrt{3}}{2} \hat{i} + \frac{1}{2} \hat{j} \right) = \frac{\sqrt{3}}{8}$$

$$\left\{ \begin{aligned} CA = OB + BA &= \hat{i} \cos 30^\circ + \hat{j} \sin 30^\circ \\ &= \left(\frac{\sqrt{3}}{2} \hat{i} + \frac{1}{2} \hat{j} \right) \end{aligned} \right.$$

Ans.

Example 29. Find the directional derivative of $V = xy^2i + zy^2j + xz^2k$ at the point (2, 0, 3) in the direction of the outward normal to the sphere $x^2 + y^2 + z^2 = 14$ at the point (3, 2, 1). (A.M.I.E.T.E., Dec. 2007)

Solution. $V^2 = \vec{V} \cdot \vec{V}$

$$= (xy^2i + zy^2j + xz^2k) \cdot (xy^2i + zy^2j + xz^2k) = x^2y^4 + z^2y^4 + x^2z^4$$

Directional derivative

$$= \vec{\nabla} V^2 = \left(i \frac{\partial}{\partial x} + j \frac{\partial}{\partial y} + k \frac{\partial}{\partial z} \right) (x^2y^4 + z^2y^4 + x^2z^4)$$

$$= (2xy^4 + 2xz^4)\hat{i} + (4x^2y^3 + 4y^3z^2)\hat{j} + (2y^4z + 4x^2z^3)\hat{k}$$

$$\text{Directional derivative at (2, 0, 3)} = (0 + 2 \times 2 \times 81)\hat{i} + (0 + 0)\hat{j} + (0 + 4 \times 4 \times 27)\hat{k}$$

$$= 324\hat{i} + 432\hat{k} = 108(3\hat{i} + 4\hat{k}) \quad \dots(1)$$

Normal to $x^2 + y^2 + z^2 - 14 = \nabla\phi$

$$= \left(i \frac{\partial}{\partial x} + j \frac{\partial}{\partial y} + k \frac{\partial}{\partial z} \right) (x^2 + y^2 + z^2 - 14)$$

$$= (2xi + 2yj + 2zk)$$

Normal vector at (3, 2, 1)

$$= 6\hat{i} + 4\hat{j} + 2\hat{k} \quad \dots(2)$$

$$\text{Unit normal vector} = \frac{6\hat{i} + 4\hat{j} + 2\hat{k}}{\sqrt{36 + 16 + 4}} = \frac{2(3\hat{i} + 2\hat{j} + \hat{k})}{2\sqrt{14}} = \frac{3\hat{i} + 2\hat{j} + \hat{k}}{\sqrt{14}} \quad [\text{From (1), (2)}]$$

$$\text{Directional derivative along the normal} = 108(3\hat{i} + 4\hat{k}) \cdot \frac{3\hat{i} + 2\hat{j} + \hat{k}}{\sqrt{14}}$$

$$= \frac{108 \times (9 + 4)}{\sqrt{14}} = \frac{1404}{\sqrt{14}}$$

Ans.

Vectors

Example 30. Find the directional derivative of $\nabla(\nabla f)$ at the point $(1, -2, 1)$ in the direction of the normal to the surface $xy^2z = 3x + z^2$, where $f = 2x^3y^2z^4$. (U.P., I Semester, Dec 2008)

Solution. Here, we have

$$f = 2x^3y^2z^4$$

$$\nabla f = \left(i \frac{\partial}{\partial x} + j \frac{\partial}{\partial y} + k \frac{\partial}{\partial z} \right) (2x^3y^2z^4) = 6x^2y^2z^4i + 4x^3yz^4j + 8x^3y^2z^3k$$

$$\nabla(\nabla f) = \left(i \frac{\partial}{\partial x} + j \frac{\partial}{\partial y} + k \frac{\partial}{\partial z} \right) (6x^2y^2z^4i + 4x^3yz^4j + 8x^3y^2z^3k)$$

$$= 12xy^2z^4 + 4x^3z^4 + 24x^3y^2z^2$$

Directional derivative of $\nabla(\nabla f)$

$$= \left(i \frac{\partial}{\partial x} + j \frac{\partial}{\partial y} + k \frac{\partial}{\partial z} \right) (12xy^2z^4 + 4x^3z^4 + 24x^3y^2z^2)$$

$$= (12y^2z^4 + 12x^2z^4 + 72x^2y^2z^2)i + (24xyz^4 + 48x^3yz^2)j$$

$$+ (48xy^2z^3 + 16x^3z^3 + 48x^3y^2z)k$$

Directional derivative at $(1, -2, 1) = (48 + 12 + 288)i + (-48 - 96)j + (192 + 16 + 192)k$

$$= 348i - 144j + 400k$$

Normal to $(xy^2z - 3x - z^2) = \nabla(xy^2z - 3x - z^2)$

$$= \left(i \frac{\partial}{\partial x} + j \frac{\partial}{\partial y} + k \frac{\partial}{\partial z} \right) (xy^2z - 3x - z^2)$$

$$= (y^2z - 3)i + (2xyz)j + (xy^2 - 2z)k$$

Normal at $(1, -2, 1) = -4j + 2k$

Unit Normal Vector = $\frac{i - 4j + 2k}{\sqrt{1+16+4}} = \frac{1}{\sqrt{21}}(i - 4j + 2k)$

Directional derivative in the direction of normal

$$= (348i - 144j + 400k) \frac{1}{\sqrt{21}}(i - 4j + 2k)$$

$$= \frac{1}{\sqrt{21}}(348 + 576 + 800) = \frac{1724}{\sqrt{21}}$$

Ans.

Example 31. If the directional derivative of $\phi = ax^2y + by^2z + cz^2x$ at the point $(1, 1, 1)$ has maximum magnitude 15 in the direction parallel to the line $\frac{x-1}{2} = \frac{y-3}{-2} = \frac{z}{1}$,

find the values of a, b and c .

(U.P. I Semester, June 2007, Winter 2001)

Solution. Given $\phi = ax^2y + by^2z + cz^2x$

$$\nabla\phi = \left(i \frac{\partial}{\partial x} + j \frac{\partial}{\partial y} + k \frac{\partial}{\partial z} \right) (ax^2y + by^2z + cz^2x)$$

$$= i(2axy + cz^2) + j(ax^2 + 2byz) + k(by^2 + 2czx)$$

$\nabla\phi$ at the point $(1, 1, 1) = i(2a + c) + j(a + 2b) + k(b + 2c)$... (1)

We know that the maximum value of the directional derivative is in the direction of $\nabla\phi$.

i.e. $|\nabla\phi| = 15 \Rightarrow (2a + c)^2 + (2b + a)^2 + (2c + b)^2 = (15)^2$

But, the directional derivative is given to be maximum parallel to the line

Vectors

$$\frac{x-1}{2} = \frac{y-3}{-2} = \frac{z}{1} \text{ i.e., parallel to the vector } 2\hat{i} - 2\hat{j} + \hat{k}. \quad \dots(2)$$

On comparing the coefficients of (1) and (2)

$$\Rightarrow \frac{2a+c}{2} = \frac{2b+a}{-2} = \frac{2c+b}{1} \quad \dots(3)$$

$$\Rightarrow 2a+c = -2b-a \Rightarrow 3a+2b+c=0$$

and $2b+a = -2(2c+b)$

$$\Rightarrow 2b+a = -4c-2b \Rightarrow a+4b+4c=0 \quad \dots(4)$$

Rewriting (3) and (4), we have

$$\left. \begin{aligned} 3a+2b+c=0 \\ a+4b+4c=0 \end{aligned} \right\} \Rightarrow \frac{a}{4} = \frac{b}{-11} = \frac{c}{10} = k \text{ (say)}$$

$$\Rightarrow a = 4k, \quad b = -11k \text{ and } c = 10k.$$

Now, we have

$$(2a+c)^2 + (2b+a)^2 + (2c+b)^2 = (15)^2$$

$$\Rightarrow (8k+10k)^2 + (-22k+4k)^2 + (20k-11k)^2 = (15)^2$$

$$\Rightarrow k = \pm \frac{5}{9}$$

$$\Rightarrow a = \pm \frac{20}{9}, \quad b = \pm \frac{55}{9} \text{ and } c = \pm \frac{50}{9} \quad \text{Ans.}$$

Example 32. If $\vec{r} = x\hat{i} + y\hat{j} + z\hat{k}$, show that :

(i) $\text{grad } r = \frac{\vec{r}}{r}$ (ii) $\text{grad } \left(\frac{1}{r} \right) = -\frac{\vec{r}}{r^3}$ (Nagpur University, Summer 2002)

Solution. (i) $\vec{r} = x\hat{i} + y\hat{j} + z\hat{k} \Rightarrow r = \sqrt{x^2 + y^2 + z^2} \Rightarrow r^2 = x^2 + y^2 + z^2$

$$\therefore 2r \frac{\partial r}{\partial x} = 2x \Rightarrow \frac{\partial r}{\partial x} = \frac{x}{r}$$

Similarly, $\frac{\partial r}{\partial y} = \frac{y}{r}$ and $\frac{\partial r}{\partial z} = \frac{z}{r}$

$$\text{grad } r = \nabla r = \left(i \frac{\partial}{\partial x} + j \frac{\partial}{\partial y} + k \frac{\partial}{\partial z} \right) r = i \frac{\partial r}{\partial x} + j \frac{\partial r}{\partial y} + k \frac{\partial r}{\partial z}$$

$$= i \frac{x}{r} + j \frac{y}{r} + k \frac{z}{r} = \frac{x\hat{i} + y\hat{j} + z\hat{k}}{r} = \frac{\vec{r}}{r}$$

Proved.

(ii) $\text{grad } \left(\frac{1}{r} \right) = \nabla \left(\frac{1}{r} \right) = \left(i \frac{\partial}{\partial x} + j \frac{\partial}{\partial y} + k \frac{\partial}{\partial z} \right) \left(\frac{1}{r} \right) = \hat{i} \frac{\partial}{\partial x} \left(\frac{1}{r} \right) + \hat{j} \frac{\partial}{\partial y} \left(\frac{1}{r} \right) + \hat{k} \frac{\partial}{\partial z} \left(\frac{1}{r} \right)$

$$= \hat{i} \left(-\frac{1}{r^2} \frac{\partial r}{\partial x} \right) + \hat{j} \left(-\frac{1}{r^2} \frac{\partial r}{\partial y} \right) + \hat{k} \left(-\frac{1}{r^2} \frac{\partial r}{\partial z} \right)$$

$$= \hat{i} \left(-\frac{1}{r^2} \frac{x}{r} \right) + \hat{j} \left(-\frac{1}{r^2} \frac{y}{r} \right) + \hat{k} \left(-\frac{1}{r^2} \frac{z}{r} \right) = -\frac{x\hat{i} + y\hat{j} + z\hat{k}}{r^3} = -\frac{\vec{r}}{r^3}$$

Proved.

Example 33. Prove that $\nabla^2 f(r) = f''(r) + \frac{2}{r} f'(r)$. (K. University, Dec. 2008)

Solution.

Vectors

$$\begin{aligned} \nabla f(r) &= \left(i \frac{\partial}{\partial x} + j \frac{\partial}{\partial y} + k \frac{\partial}{\partial z} \right) f(r) \\ &= i f'(r) \frac{\partial r}{\partial x} + j f'(r) \frac{\partial r}{\partial y} + k f'(r) \frac{\partial r}{\partial z} = f'(r) \left[i \frac{x}{r} + j \frac{y}{r} + k \frac{z}{r} \right] \\ &= f'(r) \frac{xi + yj + zk}{r} \\ \nabla^2 f(r) &= \nabla \cdot [\nabla f(r)] = \left(i \frac{\partial}{\partial x} + j \frac{\partial}{\partial y} + k \frac{\partial}{\partial z} \right) \left[\frac{f'(r)}{r} (xi + yj + zk) \right] \\ &= \frac{\partial}{\partial x} \left[\frac{f'(r)}{r} x \right] + \frac{\partial}{\partial y} \left[\frac{f'(r)}{r} y \right] + \frac{\partial}{\partial z} \left[\frac{f'(r)}{r} z \right] \\ &= \left(\frac{\partial r}{\partial x} \right) \left(\frac{x}{r} \right) + f'(r) \frac{r - x}{r^2} + \left(f''(r) \frac{\partial r}{\partial x} \right) \left(\frac{x}{r} \right) + f'(r) \frac{r - y}{r^2} + \left(f''(r) \frac{\partial r}{\partial y} \right) \left(\frac{y}{r} \right) + f'(r) \frac{r - z}{r^2} + \left(f''(r) \frac{\partial r}{\partial z} \right) \left(\frac{z}{r} \right) + f'(r) \frac{r - z}{r^2} \\ &= \left(\frac{\partial r}{\partial x} \right) \left(\frac{x}{r} \right) + f'(r) \frac{r - x}{r^2} + \left(\frac{\partial r}{\partial y} \right) \left(\frac{y}{r} \right) + f'(r) \frac{r - y}{r^2} + \left(\frac{\partial r}{\partial z} \right) \left(\frac{z}{r} \right) + f'(r) \frac{r - z}{r^2} \\ &= \left(\frac{\partial r}{\partial x} \right) \left(\frac{x}{r} \right) + f'(r) \frac{r - x}{r^2} + \left(\frac{\partial r}{\partial y} \right) \left(\frac{y}{r} \right) + f'(r) \frac{r - y}{r^2} + \left(\frac{\partial r}{\partial z} \right) \left(\frac{z}{r} \right) + f'(r) \frac{r - z}{r^2} \\ &= \left(\frac{\partial r}{\partial x} \right) \left(\frac{x}{r} \right) + f'(r) \frac{r - x}{r^2} + \left(\frac{\partial r}{\partial y} \right) \left(\frac{y}{r} \right) + f'(r) \frac{r - y}{r^2} + \left(\frac{\partial r}{\partial z} \right) \left(\frac{z}{r} \right) + f'(r) \frac{r - z}{r^2} \\ &= f''(r) \frac{x^2}{r^2} + f'(r) \frac{y^2 + z^2}{r^3} + f''(r) \frac{y^2}{r^2} + f'(r) \frac{x^2 + z^2}{r^3} + f''(r) \frac{z^2}{r^2} + f'(r) \frac{x^2 + y^2}{r^3} \\ &= f''(r) \left[\frac{x^2}{r^2} + \frac{y^2}{r^2} + \frac{z^2}{r^2} \right] + f'(r) \left[\frac{x^2}{r^3} + \frac{y^2}{r^3} + \frac{z^2}{r^3} \right] \\ &= f''(r) \frac{x^2 + y^2 + z^2}{r^2} + f'(r) \frac{2(x^2 + y^2 + z^2)}{r^3} = f''(r) \frac{r^2}{r^2} + f'(r) \frac{2r^2}{r^3} \\ &= f''(r) + f'(r) \frac{2}{r} \end{aligned}$$

Ans.

EXERCISE 5.7

- Evaluate grad ϕ if $\phi = \log(x^2 + y^2 + z^2)$ Ans. $\frac{2(xi + yj + zk)}{x^2 + y^2 + z^2}$
- Find a unit normal vector to the surface $x^2 + y^2 + z^2 = 5$ at the point $(0, 1, 2)$. Ans. $\frac{1}{\sqrt{5}}(\hat{j} + 2\hat{k})$
(AMIETE, June 2010)
- Calculate the directional derivative of the function $\phi(x, y, z) = xy^2 + yz^3$ at the point $(1, -1, 1)$ in the direction of $(3, 1, -1)$ (A.M.I.E.T.E. Winter 2009, 2000) Ans. $\frac{5}{\sqrt{11}}$
- Find the direction in which the directional derivative of $f(x, y) = (x^2 - y^2)/xy$ at $(1, 1)$ is zero. (Nagpur Winter 2000) Ans. $\frac{\hat{i} + \hat{j}}{\sqrt{2}}$

Vectors

5. Find the directional derivative of the scalar function of $(x, y, z) = xyz$ in the direction of the outer normal to the surface $z = xy$ at the point $(3, 1, 3)$.
 Ans. $\frac{27}{\sqrt{11}}$
6. The temperature of the points in space is given by $T(x, y, z) = x^2 + y^2 - z$. A mosquito located at $(1, 1, 2)$ desires to fly in such a direction that it will get warm as soon as possible. In what direction should it move?
 Ans. $\frac{1}{3}(2\hat{i} + 2\hat{j} - \hat{k})$
7. If $\phi(x, y, z) = 3xz^2y - y^3z^2$, find $\text{grad } \phi$ at the point $(1, -2, -1)$ Ans. $-(16\hat{i} + 9\hat{j} + 4\hat{k})$
8. Find a unit vector normal to the surface $x^2y + 2xz = 4$ at the point $(2, -2, 3)$.
 Ans. $\frac{1}{3}(-\hat{i} + 2\hat{j} + 2\hat{k})$
9. What is the greatest rate of increase of the function $u = xyz^2$ at the point $(1, 0, 3)$? Ans. 9
10. If θ is the acute angle between the surfaces $xyz^2 = 3x + z^2$ and $3x^2 - y^2 + 2z = 1$ at the point $(1, -2, 1)$ show that $\cos \theta = 3/7\sqrt{6}$.
11. Find the values of constants a, b, c so that the maximum value of the directional directive of $\phi = axy^2 + byz + cz^2x^3$ at $(1, 2, -1)$ has a maximum magnitude 64 in the direction parallel to the axis of z .
 Ans. $a = b, b = 24, c = -8$
12. Find the values of λ and μ so that surfaces $\lambda x^2 - \mu yz = (\lambda + 2)x$ and $4x^2y + z^3 = 4$ intersect orthogonally at the point $(1, -1, 2)$.
 Ans. $\lambda = \frac{9}{2}, \mu = 1$
13. The position vector of a particle at time t is $R = \cos(t-1)\hat{i} + \sinh(t-1)\hat{j} + at^2\hat{k}$. If at $t = 1$, the acceleration of the particle be perpendicular to its position vector, then a is equal to
 (a) 0 (b) 1 (c) $\frac{1}{2}$ (d) $\frac{1}{\sqrt{2}}$ (AMIETE, Dec. 2009) Ans. (d)

DIVERGENCE OF A VECTOR FUNCTION

The divergence of a vector point function \vec{F} is denoted by $\text{div } \vec{F}$ and is defined as below.

Let $\vec{F} = F_1\hat{i} + F_2\hat{j} + F_3\hat{k}$

$$\text{div } \vec{F} = \nabla \cdot \vec{F} = \left(\hat{i} \frac{\partial}{\partial x} + \hat{j} \frac{\partial}{\partial y} + \hat{k} \frac{\partial}{\partial z} \right) \cdot (F_1\hat{i} + F_2\hat{j} + F_3\hat{k}) = \frac{\partial F_1}{\partial x} + \frac{\partial F_2}{\partial y} + \frac{\partial F_3}{\partial z}$$

It is evident that $\text{div } \vec{F}$ is scalar function.

PHYSICAL INTERPRETATION OF DIVERGENCE

Let us consider the case of a fluid flow. Consider a small rectangular parallelepiped of dimensions dx, dy, dz parallel to x, y and z axes respectively.

Let $\vec{V} = V_x\hat{i} + V_y\hat{j} + V_z\hat{k}$ be the velocity of the fluid at $P(x, y, z)$.

∴ Mass of fluid flowing in through the face $ABCD$ in unit time

= Velocity \times Area of the face = $V_x (dy dz)$

Mass of fluid flowing out across the face $PQRS$ per unit time

$$= V_x(x + dx) (dy dz)$$

$$= \left(V_x + \frac{\partial V_x}{\partial x} dx \right) (dy dz)$$

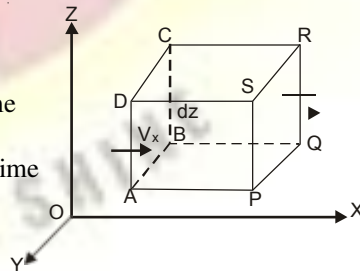

Net decrease in mass of fluid in the parallelepiped corresponding to the flow along x -axis per unit time

Vectors

Solution. $\text{div}(\vec{u}r) = \left(\frac{\partial}{\partial x} + \frac{\partial}{\partial y} + \frac{\partial}{\partial z} \right) \cdot [(x^2 + y^2 + z^2)(x\hat{i} + y\hat{j} + z\hat{k})]$

$$= \left(\frac{\partial}{\partial x} + \frac{\partial}{\partial y} + \frac{\partial}{\partial z} \right) \cdot [(x^2 + y^2 + z^2)x\hat{i} + (x^2 + y^2 + z^2)y\hat{j} + (x^2 + y^2 + z^2)z\hat{k}]$$

$$= \frac{\partial}{\partial x}(x^3 + xy^2 + xz^2) + \frac{\partial}{\partial y}(x^2y + y^3 + yz^2) + \frac{\partial}{\partial z}(x^2z + y^2z + z^3)$$

$$= (3x^2 + y^2 + z^2) + (x^2 + 3y^2 + z^2) + (x^2 + y^2 + 3z^2) = 5(x^2 + y^2 + z^2) = 5u \quad \text{Ans.}$$

Example 36. Find the value of n for which the vector $r^n \vec{r}$ is solenoidal, where $\vec{r} = x\hat{i} + y\hat{j} + z\hat{k}$.

Solution. Divergence $\nabla \cdot (r^n \vec{r}) = \nabla \cdot (x^2 + y^2 + z^2)^{n/2} (x\hat{i} + y\hat{j} + z\hat{k})$

$$= \left(\frac{\partial}{\partial x} + \frac{\partial}{\partial y} + \frac{\partial}{\partial z} \right) \cdot [(x^2 + y^2 + z^2)^{n/2} (x\hat{i} + y\hat{j} + z\hat{k})]$$

$$= \frac{\partial}{\partial x} [(x^2 + y^2 + z^2)^{n/2-1} (2x^2) + (x^2 + y^2 + z^2)^{n/2} + \frac{n}{2} (x^2 + y^2 + z^2)^{n/2-1} (2y^2)]$$

$$+ (x^2 + y^2 + z^2)^{n/2} + \frac{n}{2} (x^2 + y^2 + z^2)^{n/2-1} (2z^2) + (x^2 + y^2 + z^2)^{n/2}$$

$$= n(x^2 + y^2 + z^2)^{n/2-1} (x^2 + y^2 + z^2) + 3(x^2 + y^2 + z^2)^{n/2}$$

$$= n(x^2 + y^2 + z^2)^{n/2} + 3(x^2 + y^2 + z^2)^{n/2} = (n+3)(x^2 + y^2 + z^2)^{n/2}$$

If $r^n \vec{r}$ is solenoidal, then $(n+3)(x^2 + y^2 + z^2)^{n/2} = 0$ or $n+3=0$ or $n=-3$. **Ans.**

Example 37. Show that $\nabla \cdot \left(\frac{\vec{a} \cdot \vec{r}}{r^n} \right) = \frac{\vec{a} \cdot \vec{r}}{r^{n+2}}$. (M.U. 2005)

Solution. We have, $\frac{\vec{a} \cdot \vec{r}}{r^n} = \frac{(a_1\hat{i} + a_2\hat{j} + a_3\hat{k}) \cdot (x\hat{i} + y\hat{j} + z\hat{k})}{r^n} = \frac{a_1x + a_2y + a_3z}{r^n}$

Let $\phi = \frac{\vec{a} \cdot \vec{r}}{r^n} = \frac{a_1x + a_2y + a_3z}{r^n}$

$\therefore \frac{\partial \phi}{\partial x} = \frac{r^n a_1 - (a_1x + a_2y + a_3z) n r^{n-1} (\partial r / \partial x)}{r^{2n}}$

But $r^2 = x^2 + y^2 + z^2 \Rightarrow 2r \frac{\partial r}{\partial x} = 2x \Rightarrow \frac{\partial r}{\partial x} = \frac{x}{r}$

$\therefore \frac{\partial \phi}{\partial x} = \frac{a_1 r^n - (a_1x + a_2y + a_3z) n r^{n-2} x}{r^{2n}} = \frac{a_1}{r^n} - \frac{n(a_1x + a_2y + a_3z)x}{r^{n+2}}$

$\therefore \nabla \phi = \frac{\partial \phi}{\partial x} \hat{i} + \frac{\partial \phi}{\partial y} \hat{j} + \frac{\partial \phi}{\partial z} \hat{k}$

$$= \frac{1}{r^n} (a_1\hat{i} + a_2\hat{j} + a_3\hat{k}) - \frac{n}{r^{n+2}} [(a_1x + a_2y + a_3z)(x\hat{i} + y\hat{j} + z\hat{k})]$$

$$= \frac{\vec{a}}{r^n} - \frac{n}{r^{n+2}} (\vec{a} \cdot \vec{r}) \vec{r}$$

Vectors

Example 38. Let $\vec{r} = x\hat{i} + y\hat{j} + z\hat{k}$, $r = |\vec{r}|$ and \vec{a} is a constant vector. Find the value of

$$\operatorname{div} \left(\frac{\vec{a} \times \vec{r}}{r^n} \right)$$

Solution. Let $\vec{a} = a_1\hat{i} + a_2\hat{j} + a_3\hat{k}$

$$\vec{a} \times \vec{r} = (a_1\hat{i} + a_2\hat{j} + a_3\hat{k}) \times (x\hat{i} + y\hat{j} + z\hat{k})$$

$$= \begin{vmatrix} \hat{i} & \hat{j} & \hat{k} \\ a_1 & a_2 & a_3 \\ x & y & z \end{vmatrix} = (a_2z - a_3y)\hat{i} - (a_1z - a_3x)\hat{j} + (a_1y - a_2x)\hat{k}$$

$$\frac{\vec{a} \times \vec{r}}{|\vec{r}|^n} = \frac{(a_2z - a_3y)\hat{i} - (a_1z - a_3x)\hat{j} + (a_1y - a_2x)\hat{k}}{(x^2 + y^2 + z^2)^{n/2}}$$

$$\operatorname{div} \left(\frac{\vec{a} \times \vec{r}}{|\vec{r}|^n} \right) = \vec{\nabla} \cdot \frac{\vec{a} \times \vec{r}}{|\vec{r}|^n}$$

$$= \left(\hat{i} \frac{\partial}{\partial x} + \hat{j} \frac{\partial}{\partial y} + \hat{k} \frac{\partial}{\partial z} \right) \frac{(a_2z - a_3y)\hat{i} - (a_1z - a_3x)\hat{j} + (a_1y - a_2x)\hat{k}}{(x^2 + y^2 + z^2)^{n/2}}$$

$$= \frac{\partial}{\partial x} \frac{a_2z - a_3y}{(x^2 + y^2 + z^2)^{n/2}} - \frac{\partial}{\partial y} \frac{a_1z - a_3x}{(x^2 + y^2 + z^2)^{n/2}} + \frac{\partial}{\partial z} \frac{(a_1y - a_2x)}{(x^2 + y^2 + z^2)^{n/2}}$$

$$= \frac{n}{2} \frac{(a_2z - a_3y)2x}{(x^2 + y^2 + z^2)^{\frac{n+2}{2}}} - \frac{n}{2} \frac{(a_1z - a_3x)2y}{(x^2 + y^2 + z^2)^{\frac{n+2}{2}}} - \frac{n}{2} \frac{(a_1y - a_2x)2z}{(x^2 + y^2 + z^2)^{\frac{n+2}{2}}}$$

$$= -\frac{n}{(x^2 + y^2 + z^2)^{\frac{n+2}{2}}} [(a_2z - a_3y)x - (a_1z - a_3x)y + (a_1y - a_2x)z]$$

$$= -\frac{n}{(x^2 + y^2 + z^2)^{\frac{n+2}{2}}} [a_2zx - a_3xy - a_1yz + a_3xy + a_1yz - a_2zx] = 0 \quad \text{Ans.}$$

Example 39. Find the directional derivative of $\operatorname{div}(\vec{u})$ at the point $(1, 2, 2)$ in the direction of the outer normal of the sphere $x^2 + y^2 + z^2 = 9$ for $\vec{u} = x^4\hat{i} + y^4\hat{j} + z^4\hat{k}$.

Solution. $\operatorname{div}(\vec{u}) = \vec{\nabla} \cdot \vec{u}$

$$= \left(\hat{i} \frac{\partial}{\partial x} + \hat{j} \frac{\partial}{\partial y} + \hat{k} \frac{\partial}{\partial z} \right) (x^4\hat{i} + y^4\hat{j} + z^4\hat{k}) = 4x^3\hat{i} + 4y^3\hat{j} + 4z^3\hat{k}$$

Outer normal of the sphere $= \vec{\nabla}(x^2 + y^2 + z^2 - 9)$

$$= \left(\hat{i} \frac{\partial}{\partial x} + \hat{j} \frac{\partial}{\partial y} + \hat{k} \frac{\partial}{\partial z} \right) (x^2 + y^2 + z^2 - 9) = 2x\hat{i} + 2y\hat{j} + 2z\hat{k}$$

Outer normal of the sphere at $(1, 2, 2) = 2\hat{i} + 4\hat{j} + 4\hat{k}$... (1)

Directional derivative $= \vec{\nabla} \cdot (4x^3\hat{i} + 4y^3\hat{j} + 4z^3\hat{k})$

$$= \left(\hat{i} \frac{\partial}{\partial x} + \hat{j} \frac{\partial}{\partial y} + \hat{k} \frac{\partial}{\partial z} \right) (4x^3 + 4y^3 + 4z^3) = 12x^2\hat{i} + 12y^2\hat{j} + 12z^2\hat{k}$$

Directional derivative at $(1, 2, 2) = 12\hat{i} + 48\hat{j} + 48\hat{k}$... (2)

Vectors

Directional derivative along the outer normal = $(12\hat{i} + 48\hat{j} + 48\hat{k}) \cdot \frac{2\hat{i} + 4\hat{j} + 4\hat{k}}{\sqrt{4+16+16}}$
 [From (1), (2)]
 $= \frac{24 + 192 + 192}{6} = 68$ **Ans.**

Example 40. Show that $\text{div}(\text{grad } r^n) = n(n+1)r^{n-2}$, where
 $r = \sqrt{x^2 + y^2 + z^2}$

Hence, show that $\Delta^2\left(\frac{1}{r}\right) = 0$. (U.P. I Semester, Dec. 2004, Winter 2002)

Solution. $\text{grad}(r^n) = \hat{i} \frac{\partial}{\partial x} r^n + \hat{j} \frac{\partial}{\partial y} r^n + \hat{k} \frac{\partial}{\partial z} r^n$ by definition
 $= \hat{i} n r^{n-1} \frac{\partial r}{\partial x} + \hat{j} n r^{n-1} \frac{\partial r}{\partial y} + \hat{k} n r^{n-1} \frac{\partial r}{\partial z}$
 $= n r^{n-1} \left[\hat{i} \left(\frac{x}{r}\right) + \hat{j} \left(\frac{y}{r}\right) + \hat{k} \left(\frac{z}{r}\right) \right] = n r^{n-1} \frac{(x\hat{i} + y\hat{j} + z\hat{k})}{r} = n r^{n-2} \vec{r}$
 Thus, $\text{grad}(r^n) = n r^{n-2} \vec{r}$

$\therefore \text{div grad } r^n = \text{div} [n r^{n-2} \vec{r}]$
 $= \left(\hat{i} \frac{\partial}{\partial x} + \hat{j} \frac{\partial}{\partial y} + \hat{k} \frac{\partial}{\partial z} \right) \cdot (n r^{n-2} x\hat{i} + n r^{n-2} y\hat{j} + n r^{n-2} z\hat{k})$ [From (1)]
 $= \frac{\partial}{\partial x} (n r^{n-2} x) + \frac{\partial}{\partial y} (n r^{n-2} y) + \frac{\partial}{\partial z} (n r^{n-2} z)$ (By definition)
 $= \left(n r^{n-2} + n x (n-2) r^{n-3} \frac{\partial r}{\partial x} \right) + \left(n r^{n-2} + n y (n-2) r^{n-3} \frac{\partial r}{\partial y} \right) + \left(n r^{n-2} + n z (n-2) r^{n-3} \frac{\partial r}{\partial z} \right)$
 $= 3n r^{n-2} + n(n-2) r^{n-3} \left[x \frac{\partial r}{\partial x} + y \frac{\partial r}{\partial y} + z \frac{\partial r}{\partial z} \right]$
 $= 3n r^{n-2} + n(n-2) r^{n-3} \left[x \left(\frac{x}{r}\right) + y \left(\frac{y}{r}\right) + z \left(\frac{z}{r}\right) \right]$
 $= 3n r^{n-2} + n(n-2) r^{n-4} [x^2 + y^2 + z^2]$
 $= 3n r^{n-2} + n(n-2) r^{n-4} \cdot r^2$ ($\because r^2 = x^2 + y^2 + z^2$)
 $= r^{n-2} [3n + n^2 - 2n] = r^{n-2} (n^2 + n) = n(n+1) r^{n-2}$

If we put $n = -1$
 $\text{div grad}(r^{-1}) = -1(-1+1)r^{-1-2}$
 $\Rightarrow \nabla^2\left(\frac{1}{r}\right) = 0$

Ques. If $\vec{r} = x\hat{i} + y\hat{j} + z\hat{k}$, and $r = |\vec{r}|$ find $\text{div} \left(\frac{\vec{r}}{r^2} \right)$. (U.P. I Sem., Dec. 2006) **Ans.** $\frac{1}{r^2}$

Vectors

EXERCISE 5.8

1. If $r = xi + yj + zk$ and $r = \frac{r}{|r|}$, show that (i) $\text{div} \left(\frac{r}{|r|^3} \right) = 0$,
 (ii) $\text{div} (\text{grad } r^n) = n(n+1)r^{n-2}$ (AMIETE, June 2010) (iii) $\text{div} (r \phi) = 3\phi + r \text{grad } \phi$.
2. Show that the vector $V = (x+3y)i + (y-3z)j + (x-2z)k$ is solenoidal. (R.G.P.V., Bhopal, Dec. 2003)
3. Show that $\nabla \cdot (\phi A) = \nabla \phi \cdot A + \phi (\nabla \cdot A)$
4. If ρ, ϕ, z are cylindrical coordinates, show that $\text{grad} (\log \rho)$ and $\text{grad } \phi$ are solenoidal vectors.
5. Obtain the expression for $\nabla^2 f$ in spherical coordinates from their corresponding expression in orthogonal curvilinear coordinates.

Prove the following:

6. $\nabla \cdot (\phi F) = (\nabla \phi) \cdot F + \phi (\nabla \cdot F)$
7. (a) $\nabla \cdot (\nabla \phi) = \nabla^2 \phi$ (b) $\nabla \times \frac{(\vec{A} \times \vec{R})}{r^n} = \frac{(2-n)\vec{A}}{r^n} + \frac{n(\vec{A} \cdot \vec{R})\vec{R}}{r^{n+2}}$, $r = |\vec{R}|$
8. $\text{div} (f \nabla g) - \text{div} (g \nabla f) = f \nabla^2 g - g \nabla^2 f$ (U.P., I semester, Dec. 2006)

CURL

The curl of a vector point function F is defined as below

$$\begin{aligned} \text{curl } \vec{F} &= \nabla \times \vec{F} \\ &= \begin{vmatrix} \hat{i} & \hat{j} & \hat{k} \\ \frac{\partial}{\partial x} & \frac{\partial}{\partial y} & \frac{\partial}{\partial z} \\ F_1 & F_2 & F_3 \end{vmatrix} = \hat{i} \left(\frac{\partial F_3}{\partial y} - \frac{\partial F_2}{\partial z} \right) - \hat{j} \left(\frac{\partial F_3}{\partial x} - \frac{\partial F_1}{\partial z} \right) + \hat{k} \left(\frac{\partial F_2}{\partial x} - \frac{\partial F_1}{\partial y} \right) \end{aligned}$$

$(F = F_1 i + F_2 j + F_3 k)$

Curl F is a vector quantity.

PHYSICAL MEANING OF CURL

(M.D.U., Dec. 2009, U.P. I Semester, Winter 2009, 2000)

We know that $\vec{V} = \omega \times r$, where ω is the angular velocity, \vec{V} is the linear velocity and r is the position vector of a point on the rotating body.

$$\begin{aligned} \text{Curl } \vec{V} &= \nabla \times \vec{V} \\ &= \nabla \times (\omega \times r) = \nabla \times [(\omega_1 \hat{i} + \omega_2 \hat{j} + \omega_3 \hat{k}) \times (x \hat{i} + y \hat{j} + z \hat{k})] \\ &= \nabla \times \begin{vmatrix} \hat{i} & \hat{j} & \hat{k} \\ \omega_1 & \omega_2 & \omega_3 \\ x & y & z \end{vmatrix} = \nabla \times [(\omega_2 z - \omega_3 y) \hat{i} - (\omega_1 z - \omega_3 x) \hat{j} + (\omega_1 y - \omega_2 x) \hat{k}] \\ &= \left(\hat{i} \frac{\partial}{\partial x} + \hat{j} \frac{\partial}{\partial y} + \hat{k} \frac{\partial}{\partial z} \right) \times [(\omega_2 z - \omega_3 y) \hat{i} - (\omega_1 z - \omega_3 x) \hat{j} + (\omega_1 y - \omega_2 x) \hat{k}] \end{aligned}$$

$$= \begin{vmatrix} \hat{i} & \hat{j} & \hat{k} \\ \frac{\partial}{\partial x} & \frac{\partial}{\partial y} & \frac{\partial}{\partial z} \\ \omega_2 z - \omega_3 y & \omega_3 x - \omega_1 z & \omega_1 y - \omega_2 x \end{vmatrix}$$

$$= (\omega_1 + \omega_2)\hat{i} - (-\omega_2 - \omega_2)\hat{j} + (\omega_3 + \omega_3)\hat{k} = 2(\omega_1\hat{i} + \omega_2\hat{j} + \omega_3\hat{k}) = 2\omega$$

$\vec{\text{Curl}} V = 2\omega$ which shows that curl of a vector field is connected with rotational properties of the vector field and justifies the name *rotation* used for curl.

If $\vec{\text{Curl}} F = 0$, the field F is termed as *irrotational*.

Example 41. Find the divergence and curl of $\vec{v} = (xyz)\hat{i} + (3x^2y)\hat{j} + (xz^2 - y^2z)\hat{k}$ at $(2, -1, 1)$ (Nagpur University, Summer 2003)

Solution. Here, we have

$$\vec{v} = (xyz)\hat{i} + (3x^2y)\hat{j} + (xz^2 - y^2z)\hat{k}$$

$$\text{Div. } \vec{v} = \nabla \cdot \vec{v}$$

$$\text{Div } \vec{v} = \frac{\partial}{\partial x}(xyz) + \frac{\partial}{\partial y}(3x^2y) + \frac{\partial}{\partial z}(xz^2 - y^2z)$$

$$= yz + 3x^2 + 2xz - y^2 = -1 + 12 + 4 - 1 = 14 \text{ at } (2, -1, 1)$$

$$\text{Curl } \vec{v} = \begin{vmatrix} \hat{i} & \hat{j} & \hat{k} \\ \frac{\partial}{\partial x} & \frac{\partial}{\partial y} & \frac{\partial}{\partial z} \\ xyz & 3x^2y & xz^2 - y^2z \end{vmatrix} = -2yz\hat{i} - (z^2 - xy)\hat{j} + (6xy - xz)\hat{k}$$

$$\text{Curl at } (2, -1, 1) = -2(-1)(1)\hat{i} + \{(2)(-1) - 1\}\hat{j} + \{6(2)(-1) - 2(1)\}\hat{k}$$

$$= 2\hat{i} - 3\hat{j} - 14\hat{k}$$

$$\vec{v} = \frac{xi + yj + zk}{\sqrt{x^2 + y^2 + z^2}}$$

Ans.

Example 42. If $\vec{V} = \frac{xi + yj + zk}{\sqrt{x^2 + y^2 + z^2}}$, find the value of curl V .

(U.P., I Semester, Winter 2000)

Solution.

$$\text{Curl } \vec{V} = \nabla \times \vec{V} = \begin{vmatrix} \hat{i} & \hat{j} & \hat{k} \\ \frac{\partial}{\partial x} & \frac{\partial}{\partial y} & \frac{\partial}{\partial z} \\ \frac{x}{\sqrt{x^2 + y^2 + z^2}} & \frac{y}{\sqrt{x^2 + y^2 + z^2}} & \frac{z}{\sqrt{x^2 + y^2 + z^2}} \end{vmatrix}$$

Vectors

$$\begin{aligned}
 &= \hat{i} \left[\frac{\partial}{\partial y} \left(\frac{z}{(x^2 + y^2 + z^2)^{1/2}} \right) - \frac{\partial}{\partial z} \left(\frac{y}{(x^2 + y^2 + z^2)^{1/2}} \right) \right] - \hat{j} \left[\frac{\partial}{\partial x} \left(\frac{z}{(x^2 + y^2 + z^2)^{1/2}} \right) \right. \\
 &\quad \left. - \frac{\partial}{\partial z} \left(\frac{x}{(x^2 + y^2 + z^2)^{1/2}} \right) \right] + \hat{k} \left[\frac{\partial}{\partial x} \left(\frac{y}{(x^2 + y^2 + z^2)^{1/2}} \right) - \frac{\partial}{\partial y} \left(\frac{x}{(x^2 + y^2 + z^2)^{1/2}} \right) \right] \\
 &= \hat{i} \left[\frac{-yz}{(x^2 + y^2 + z^2)^{3/2}} + \frac{y.z}{(x^2 + y^2 + z^2)^{3/2}} \right] - \hat{j} \left[\frac{-zx}{(x^2 + y^2 + z^2)^{3/2}} + \frac{zx}{(x^2 + y^2 + z^2)^{3/2}} \right] \\
 &\quad + \hat{k} \left[\frac{-xy}{(x^2 + y^2 + z^2)^{3/2}} + \frac{xy}{(x^2 + y^2 + z^2)^{3/2}} \right] = 0 \quad \text{Ans.}
 \end{aligned}$$

Example 43. Prove that $(y^2 - z^2 + 3yz - 2x)\hat{i} + (3xz + 2xy)\hat{j} + (3xy - 2xz + 2z)\hat{k}$ is both solenoidal and irrotational. (U.P., I Sem, Dec. 2008)

Solution. Let $\vec{F} = (y^2 - z^2 + 3yz - 2x)\hat{i} + (3xz + 2xy)\hat{j} + (3xy - 2xz + 2z)\hat{k}$

For solenoidal, we have to prove $\nabla \cdot \vec{F} = 0$.

$$\begin{aligned}
 \text{Now, } \nabla \cdot \vec{F} &= \left[\hat{i} \frac{\partial}{\partial x} + \hat{j} \frac{\partial}{\partial y} + \hat{k} \frac{\partial}{\partial z} \right] \cdot [(y^2 - z^2 + 3yz - 2x)\hat{i} + (3xz + 2xy)\hat{j} + (3xy - 2xz + 2z)\hat{k}] \\
 &= -2 + 2x - 2x + 2 = 0
 \end{aligned}$$

Thus, \vec{F} is solenoidal. For irrotational, we have to prove $\text{Curl } \vec{F} = 0$.

$$\begin{aligned}
 \text{Now, } \text{Curl } \vec{F} &= \begin{vmatrix} \hat{i} & \hat{j} & \hat{k} \\ \frac{\partial}{\partial x} & \frac{\partial}{\partial y} & \frac{\partial}{\partial z} \\ y^2 - z^2 + 3yz - 2x & 3xz + 2xy & 3xy - 2xz + 2z \end{vmatrix} \\
 &= (3z + 2y - 2y + 3z)\hat{i} - (-2z + 3y - 3y + 2z)\hat{j} + (3z + 2y - 2y - 3z)\hat{k} \\
 &= 0\hat{i} + 0\hat{j} + 0\hat{k} = 0
 \end{aligned}$$

Thus, \vec{F} is irrotational.

Hence, \vec{F} is both solenoidal and irrotational.

Proved.

Example 44. Determine the constants a and b such that the curl of vector

$$\vec{A} = (2xy + 3yz)\hat{i} + (x^2 + axz - 4z^2)\hat{j} - (3xy + byz)\hat{k} \text{ is zero.}$$

(U.P. I Semester, Dec 2008)

Solution.

$$\text{Curl } \vec{A} = \left(\hat{i} \frac{\partial}{\partial x} + \hat{j} \frac{\partial}{\partial y} + \hat{k} \frac{\partial}{\partial z} \right) \times [(2xy + 3yz)\hat{i} + (x^2 + axz - 4z^2)\hat{j} - (3xy + byz)\hat{k}]$$

$$= \begin{vmatrix} \hat{i} & \hat{j} & \hat{k} \\ \frac{\partial}{\partial x} & \frac{\partial}{\partial y} & \frac{\partial}{\partial z} \\ 2xy + 3yz & x^2 + axz - 4z^2 & -3xy - byz \end{vmatrix}$$

Vectors

$$\begin{aligned}
 &= [-3x - bz - ax + 8z]\hat{i} - [-3y - 3y]\hat{j} + [2x + az - 2x - 3z]\hat{k} \\
 &= [-x(3+a) + z(8-b)]\hat{i} + 6y\hat{j} + z(-3+a)\hat{k} \\
 &= 0 \qquad \qquad \qquad \text{(given)}
 \end{aligned}$$

$$\begin{aligned}
 \text{i.e., } 3 + a = 0 \quad \text{and } 8 - b = 0, \qquad \qquad \qquad -3 + a = 0 \\
 a = -3, \quad b = 8 \qquad \qquad \qquad \Rightarrow \qquad \qquad \qquad a = 3
 \end{aligned}$$

Ans.**Example 45.** If a vector field is given by

$$\vec{F} = (x^2 - y^2 + x)\hat{i} - (2xy + y)\hat{j}. \text{ Is this field irrotational? If so, find its scalar potential.}$$

(U.P. I Semester, Dec 2009)

Solution. Here, we have

$$\vec{F} = (x^2 - y^2 + x)\hat{i} - (2xy + y)\hat{j}$$

$$\text{Curl } \vec{F} = \nabla \times \vec{F}$$

$$\begin{aligned}
 &= \begin{vmatrix} \hat{i} & \hat{j} & \hat{k} \\ \frac{\partial}{\partial x} & \frac{\partial}{\partial y} & \frac{\partial}{\partial z} \\ x^2 - y^2 + x & -(2xy + y) & 0 \end{vmatrix} \\
 &= \hat{i}(0 - 0) - \hat{j}(0 - 0) + \hat{k}(-2y + 2y) = 0
 \end{aligned}$$

Hence, vector field \vec{F} is irrotational.To find the scalar potential function ϕ

$$\vec{F} = \nabla \phi$$

$$\begin{aligned}
 d\phi &= \frac{\partial \phi}{\partial x} dx + \frac{\partial \phi}{\partial y} dy + \frac{\partial \phi}{\partial z} dz = \left[\hat{i} \frac{\partial \phi}{\partial x} + \hat{j} \frac{\partial \phi}{\partial y} + \hat{k} \frac{\partial \phi}{\partial z} \right] \cdot (\hat{i} dx + \hat{j} dy + \hat{k} dz) \\
 &= \left(\hat{i} \frac{\partial \phi}{\partial x} + \hat{j} \frac{\partial \phi}{\partial y} + \hat{k} \frac{\partial \phi}{\partial z} \right) \cdot (d\vec{r}) = \nabla \phi \cdot d\vec{r} = \vec{F} \cdot d\vec{r}
 \end{aligned}$$

$$\begin{aligned}
 &= [(x^2 - y^2 + x)\hat{i} - (2xy + y)\hat{j}] \cdot (\hat{i} dx + \hat{j} dy + \hat{k} dz) \\
 &= (x^2 - y^2 + x)dx - (2xy + y)dy.
 \end{aligned}$$

$$\begin{aligned}
 \phi &= \int [(x^2 - y^2 + x)dx - (2xy + y)dy] + c \\
 &= \int \left[x^2 dx + x dx - y^2 dx - 2xy dy - y dy \right] + c = \frac{x^3}{3} + \frac{x^2}{2} - \frac{y^2}{2} - xy^2 + c
 \end{aligned}$$

$$\text{Hence, the scalar potential is } \frac{x^3}{3} + \frac{x^2}{2} - \frac{y^2}{2} - xy^2 + c$$

Ans.**Example 46.** Find the scalar potential function f for $\vec{A} = y^2\hat{i} + 2xy\hat{j} - z^2\hat{k}$.

(Gujarat, I Semester, Jan. 2009)

Solution. We have, $\vec{A} = y^2\hat{i} + 2xy\hat{j} - z^2\hat{k}$

$$\text{Curl } \vec{A} = \nabla \times \vec{A} = \begin{vmatrix} \hat{i} & \hat{j} & \hat{k} \\ \frac{\partial}{\partial x} & \frac{\partial}{\partial y} & \frac{\partial}{\partial z} \\ y^2 & 2xy & -z^2 \end{vmatrix}$$

Vectors

$$= \begin{vmatrix} \hat{i} & \hat{j} & \hat{k} \\ \frac{\partial}{\partial x} & \frac{\partial}{\partial y} & \frac{\partial}{\partial z} \\ y^2 & 2xy & -z^2 \end{vmatrix} = \hat{i}(0) - \hat{j}(0) + \hat{k}(2y - 2y) = 0$$

Hence, \vec{A} is irrotational. To find the scalar potential function f .

$$\begin{aligned} \vec{A} &= \nabla f = \frac{\partial f}{\partial x} \hat{i} + \frac{\partial f}{\partial y} \hat{j} + \frac{\partial f}{\partial z} \hat{k} \\ df &= \left(\frac{\partial f}{\partial x} \hat{i} + \frac{\partial f}{\partial y} \hat{j} + \frac{\partial f}{\partial z} \hat{k} \right) \cdot (i dx + j dy + k dz) \\ &= \left(i \frac{\partial}{\partial x} + j \frac{\partial}{\partial y} + k \frac{\partial}{\partial z} \right) f \cdot dr = \nabla f \cdot dr \\ &= \vec{A} \cdot dr \quad (A = \nabla f) \\ &= (y^2 \hat{i} + 2xy \hat{j} - z^2 \hat{k}) \cdot (i dx + j dy + k dz) \\ &= y^2 dx + 2xy dy - z^2 dz = d(xy^2) - z^2 dz \\ f &= \int d(xy^2) - \int z^2 dz = xy^2 - \frac{z^3}{3} + C \quad \text{Ans.} \end{aligned}$$

Example 47. A vector field is given by $\vec{A} = (x^2 + xy^2)\hat{i} + (y^2 + x^2y)\hat{j}$. Show that the field is irrotational and find the scalar potential. (Nagpur Univeristy, Summer 2003, Winter 2002)

Solution. \vec{A} is irrotational if $\text{curl } \vec{A} = 0$

$$\text{Curl } \vec{A} = \nabla \times \vec{A} = \begin{vmatrix} \hat{i} & \hat{j} & \hat{k} \\ \frac{\partial}{\partial x} & \frac{\partial}{\partial y} & \frac{\partial}{\partial z} \\ x^2 + xy^2 & y^2 + x^2y & 0 \end{vmatrix} = \hat{i}(0-0) - \hat{j}(0-0) + \hat{k}(2xy - 2xy) = 0$$

Hence, \vec{A} is irrotational. If ϕ is the scalar potential, then

$$\begin{aligned} \vec{A} &= \text{grad } \phi \\ d\phi &= \frac{\partial \phi}{\partial x} dx + \frac{\partial \phi}{\partial y} dy + \frac{\partial \phi}{\partial z} dz \quad [\text{Total differential coefficient}] \\ &= \left(i \frac{\partial}{\partial x} + j \frac{\partial}{\partial y} + k \frac{\partial}{\partial z} \right) \cdot (i dx + j dy + k dz) = \text{grad } \phi \cdot dr \\ &= \vec{A} \cdot dr = (x^2 + xy^2) dx + (y^2 + x^2y) dy = x^2 dx + y^2 dy + (x dx)y^2 + (x^2)(y dy) \\ \phi &= \int x^2 dx + \int y^2 dy + \int [(x dx)y^2 + (x^2)(y dy)] = \frac{x^3}{3} + \frac{y^3}{3} + \frac{x^2 y^2}{2} + c \quad \text{Ans.} \end{aligned}$$

Example 48. Show that $\vec{V} = 2xyz\hat{i} + (x^2z + 2y^2)\hat{j} + x^2yk\hat{k}$ is irrotational and find a

scalar function $u(x, y, z)$ such that $\vec{V} = \text{grad } (u)$.

Solution. $\vec{V}(x, y, z) = 2xyz\hat{i} + (x^2z + 2y^2)\hat{j} + x^2yk\hat{k}$

Vectors

$$\begin{aligned} \text{Curl } \vec{V} &= \left(\hat{i} \frac{\partial}{\partial x} + \hat{j} \frac{\partial}{\partial y} + \hat{k} \frac{\partial}{\partial z} \right) \times [2xyz\hat{i} + (x^2z + 2y)\hat{j} + x^2y\hat{k}] \\ &= \begin{vmatrix} \hat{i} & \hat{j} & \hat{k} \\ \frac{\partial}{\partial x} & \frac{\partial}{\partial y} & \frac{\partial}{\partial z} \\ 2xyz & x^2z + 2y & x^2y \end{vmatrix} \\ &= (x^2 - x^2)\hat{i} - (2xy - 2xy)\hat{j} + (2xz - 2xz)\hat{k} = 0 \end{aligned}$$

Hence, $\vec{V}(x, y, z)$ is irrotational.

To find corresponding scalar function u , consider the following relations given

$$\vec{V} = \text{grad}(u)$$

or $\vec{V} = \nabla(u)$... (1)

$$du = \frac{\partial u}{\partial x} dx + \frac{\partial u}{\partial y} dy + \frac{\partial u}{\partial z} dz \quad (\text{Total differential coefficient})$$

$$= \left(\hat{i} \frac{\partial u}{\partial x} + \hat{j} \frac{\partial u}{\partial y} + \hat{k} \frac{\partial u}{\partial z} \right) \cdot (\hat{i} dx + \hat{j} dy + \hat{k} dz)$$

$$= \nabla u \cdot d\vec{r} = \vec{V} \cdot d\vec{r} \quad [\text{From (1)}]$$

$$= [2xyz\hat{i} + (x^2z + 2y)\hat{j} + x^2y\hat{k}] \cdot (\hat{i} dx + \hat{j} dy + \hat{k} dz)$$

$$= 2xyz dx + (x^2z + 2y) dy + x^2y dz$$

$$= y(2xz dx + x^2 dz) + (x^2z) dy + 2y dy$$

$$= [y d(x^2z) + (x^2z) dy] + 2y dy = d(x^2yz) + 2y dy$$

Integrating, we get $u = x^2yz + y^2$ **Ans.**

Example 49. A fluid motion is given by $\vec{v} = (y + z)\hat{i} + (z + x)\hat{j} + (x + y)\hat{k}$. Show that the motion is irrotational and hence find the velocity potential.

(Uttarakhand, I Semester 2006; U.P., I Semester, Winter 2003)

Solution. $\text{Curl } \vec{v} = \nabla \times \vec{v}$

$$= \left(\hat{i} \frac{\partial}{\partial x} + \hat{j} \frac{\partial}{\partial y} + \hat{k} \frac{\partial}{\partial z} \right) \times [(y + z)\hat{i} + (z + x)\hat{j} + (x + y)\hat{k}]$$

$$= \begin{vmatrix} \hat{i} & \hat{j} & \hat{k} \\ \frac{\partial}{\partial x} & \frac{\partial}{\partial y} & \frac{\partial}{\partial z} \\ y + z & z + x & x + y \end{vmatrix} = (1 - 1)\hat{i} - (1 - 1)\hat{j} + (1 - 1)\hat{k} = 0$$

Hence, \vec{v} is irrotational.

To find the corresponding velocity potential ϕ , consider the following relation.

$$\vec{v} = \nabla\phi$$

$$d\phi = \frac{\partial \phi}{\partial x} dx + \frac{\partial \phi}{\partial y} dy + \frac{\partial \phi}{\partial z} dz \quad [\text{Total Differential coefficient}]$$

Vectors

$$\begin{aligned}
 &= \left(\hat{i} \frac{\partial \phi}{\partial x} + \hat{j} \frac{\partial \phi}{\partial y} + \hat{k} \frac{\partial \phi}{\partial z} \right) \cdot (i dx + j dy + k dz) = \left(\hat{i} \frac{\partial}{\partial x} + \hat{j} \frac{\partial}{\partial y} + \hat{k} \frac{\partial}{\partial z} \right) \phi \cdot d\vec{r} = \nabla \phi \cdot d\vec{r} = \vec{v} \cdot d\vec{r} \\
 &= [(y+z)\hat{i} + (z+x)\hat{j} + (x+y)\hat{k}] \cdot (i dx + j dy + k dz) \\
 &= (y+z) dx + (z+x) dy + (x+y) dz \\
 &= y dx + z dx + z dy + x dy + x dz + y dz \\
 \phi &= \int (y dx + x dy) + \int (z dy + y dz) + \int (z dx + x dz) \\
 \phi &= xy + yz + zx + c
 \end{aligned}$$

Velocity potential = $xy + yz + zx + c$

Ans.

Example 50. A fluid motion is given by

$$\vec{v} = (y \sin z - \sin x)\hat{i} + (x \sin z + 2yz)\hat{j} + (xy \cos z + y^2)\hat{k}$$

is the motion irrotational? If so, find the velocity potential.

Solution.

$$\begin{aligned}
 \text{Curl } \vec{v} &= \nabla \times \vec{v} \\
 &= \begin{vmatrix} \hat{i} & \hat{j} & \hat{k} \\ \frac{\partial}{\partial x} & \frac{\partial}{\partial y} & \frac{\partial}{\partial z} \\ (y \sin z - \sin x) & (x \sin z + 2yz) & (xy \cos z + y^2) \end{vmatrix} \\
 &= \begin{vmatrix} \frac{\partial}{\partial x} & \frac{\partial}{\partial y} & \frac{\partial}{\partial z} \\ y \sin z - \sin x & x \sin z + 2yz & xy \cos z + y^2 \end{vmatrix} \\
 &= (x \cos z + 2y - x \cos z - 2y)\hat{i} - [y \cos z - y \cos z]\hat{j} + (\sin z - \sin z)\hat{k} = 0
 \end{aligned}$$

Hence, the motion is irrotational.

So, $\vec{v} = \nabla \phi$ where ϕ is called velocity potential.

$$d\phi = \frac{\partial \phi}{\partial x} dx + \frac{\partial \phi}{\partial y} dy + \frac{\partial \phi}{\partial z} dz \quad \text{[Total differential coefficient]}$$

$$\begin{aligned}
 &= \left(\hat{i} \frac{\partial \phi}{\partial x} + \hat{j} \frac{\partial \phi}{\partial y} + \hat{k} \frac{\partial \phi}{\partial z} \right) \cdot (i dx + j dy + k dz) = \nabla \phi \cdot d\vec{r} = \vec{v} \cdot d\vec{r} \\
 &= [(y \sin z - \sin x)\hat{i} + (x \sin z + 2yz)\hat{j} + (xy \cos z + y^2)\hat{k}] \cdot [i dx + j dy + k dz] \\
 &= (y \sin z - \sin x) dx + (x \sin z + 2yz) dy + (xy \cos z + y^2) dz \\
 &= (y \sin z dx + x dy \sin z + x y \cos z dz) - \sin x dx + (2yz dy + y^2 dz) \\
 &= d(xy \sin z) + d(\cos x) + d(y^2 z)
 \end{aligned}$$

$$\phi = \int d(xy \sin z) + \int d(\cos x) + \int d(y^2 z)$$

$$\phi = xy \sin z + \cos x + y^2 z + c$$

Hence, Velocity potential = $xy \sin z + \cos x + y^2 z + c$.

Ans.

Example 51. Prove that $\vec{F} = r^2 \vec{r}$ is conservative and find the scalar potential ϕ such that

$$\vec{F} = \nabla \phi \quad \text{(Nagpur University, Summer 2004)}$$

Solution. Given

$$\vec{F} = r^2 \vec{r} = r^2 (x\hat{i} + y\hat{j} + z\hat{k}) = r^2 x\hat{i} + r^2 y\hat{j} + r^2 z\hat{k}$$

Consider $\nabla \times \vec{F} =$

$$\begin{vmatrix} \hat{i} & \hat{j} & \hat{k} \\ \frac{\partial}{\partial x} & \frac{\partial}{\partial y} & \frac{\partial}{\partial z} \\ r^2 x & r^2 y & r^2 z \end{vmatrix}$$

Vectors

$$\begin{aligned}
 & \hat{i} \left[\frac{\partial}{\partial y} \left(\frac{r z}{r} \right) - \frac{\partial}{\partial z} \left(\frac{r y}{r} \right) \right] - \hat{j} \left[\frac{\partial}{\partial x} \left(\frac{r z}{r} \right) - \frac{\partial}{\partial z} \left(\frac{r x}{r} \right) \right] + \hat{k} \left[\frac{\partial}{\partial x} \left(\frac{r y}{r} \right) - \frac{\partial}{\partial y} \left(\frac{r x}{r} \right) \right] \\
 &= i \left[2rz \frac{\partial}{\partial y} - 2ry \frac{\partial}{\partial z} \right] - j \left[2rz \frac{\partial}{\partial x} - 2rx \frac{\partial}{\partial z} \right] + k \left[2ry \frac{\partial}{\partial x} - 2rx \frac{\partial}{\partial y} \right] \\
 & \quad \left\{ \text{But } r^2 = x^2 + y^2 + z^2, \frac{\partial r}{\partial x} = \frac{x}{r}, \frac{\partial r}{\partial y} = \frac{y}{r}, \frac{\partial r}{\partial z} = \frac{z}{r} \right\} \\
 &= i \left[2rz \frac{y}{r} - 2ry \frac{z}{r} \right] - j \left[2rz \frac{x}{r} - 2rx \frac{z}{r} \right] + k \left[2ry \frac{x}{r} - 2rx \frac{y}{r} \right] \\
 &= i(2yz - 2yz) - j(2zx - 2zx) + k(2xy - 2xy) = 0\hat{i} - 0\hat{j} + 0\hat{k} = 0
 \end{aligned}$$

∴ $\nabla \times \vec{F} = 0$

∴ \vec{F} is irrotational ∴ F is conservative.

Consider scalar potential ϕ such that $\vec{F} = \nabla\phi$.

$$\begin{aligned}
 d\phi &= \frac{\partial\phi}{\partial x} dx + \frac{\partial\phi}{\partial y} dy + \frac{\partial\phi}{\partial z} dz && \text{[Total differential coefficient]} \\
 &= \left(i \frac{\partial\phi}{\partial x} + j \frac{\partial\phi}{\partial y} + k \frac{\partial\phi}{\partial z} \right) \cdot (i dx + j dy + k dz) \\
 &= \left(i \frac{\partial}{\partial x} + j \frac{\partial}{\partial y} + k \frac{\partial}{\partial z} \right) \phi \cdot (i dx + j dy + k dz) = \nabla\phi \cdot (i dx + j dy + k dz) \\
 &= \vec{F} \cdot (i dx + j dy + k dz) = r^2 \frac{\vec{r}}{r} \cdot (i dx + j dy + k dz) \quad (\nabla\phi = \vec{F}) \\
 &= (x^2 + y^2 + z^2) (i x + j y + k z) \cdot (i dx + j dy + k dz) \\
 &= (x^2 + y^2 + z^2) (x dx + y dy + z dz) \\
 &= x^3 dx + y^3 dy + z^3 dz + (x dx) y^2 + (x^2) (y dy) \\
 & \quad + (x dx) z^2 + z^2 (y dy) + x^2 (z dz) + y^2 (z dz) \\
 \phi &= \int x^3 dx + \int y^3 dy + \int z^3 dz + \int [(x dx)y^2 + (y dy)x^2] \\
 & \quad + \int [(x dx)z^2 + (z dz)x^2] + \int [(y dy)z^2 + (z dz)y^2] \\
 &= \frac{x^4}{4} + \frac{y^4}{4} + \frac{z^4}{4} + \frac{1}{2} x^2 y^2 + \frac{1}{2} x^2 z^2 + \frac{1}{2} y^2 z^2 + c \\
 &= \frac{1}{4} (x^4 + y^4 + z^4 + 2x^2 y^2 + 2x^2 z^2 + 2y^2 z^2) + c && \text{Ans.}
 \end{aligned}$$

Example 52. Show that the vector field $\vec{F} = \frac{\vec{r}}{|\vec{r}|^3}$ is irrotational as well as solenoidal. Find the scalar potential.

(Nagpur University, Summer 2008, 2001, U.P. I Semester Dec. 2005, 2001)

Solution.
$$\vec{F} = \frac{\vec{r}}{|\vec{r}|^3} = \frac{x\hat{i} + y\hat{j} + z\hat{k}}{(x^2 + y^2 + z^2)^{3/2}}$$

$$\text{Curl } \vec{F} = \nabla \times \vec{F} = \begin{vmatrix} \hat{i} & \hat{j} & \hat{k} \\ \frac{\partial}{\partial x} & \frac{\partial}{\partial y} & \frac{\partial}{\partial z} \\ \frac{x}{(x^2 + y^2 + z^2)^{3/2}} & \frac{y}{(x^2 + y^2 + z^2)^{3/2}} & \frac{z}{(x^2 + y^2 + z^2)^{3/2}} \end{vmatrix}$$

Vectors

$$\begin{aligned}
 &= \begin{vmatrix} \hat{i} & \hat{j} & \hat{k} \\ \frac{\partial}{\partial x} & \frac{\partial}{\partial y} & \frac{\partial}{\partial z} \\ \frac{x}{(x^2 + y^2 + z^2)^{3/2}} & \frac{y}{(x^2 + y^2 + z^2)^{3/2}} & \frac{z}{(x^2 + y^2 + z^2)^{3/2}} \end{vmatrix} \\
 &= \hat{i} \left[\frac{-3}{2} \frac{2yz}{(x^2 + y^2 + z^2)^{5/2}} + \frac{3}{2} \frac{2yz}{(x^2 + y^2 + z^2)^{5/2}} \right] \\
 &\quad - \hat{j} \left[\frac{-3}{2} \frac{2xz}{(x^2 + y^2 + z^2)^{5/2}} - \left(\frac{-3}{2} \right) \frac{2xz}{(x^2 + y^2 + z^2)^{5/2}} \right] \\
 &\quad + \hat{k} \left[\frac{-3}{2} \frac{2xy}{(x^2 + y^2 + z^2)^{5/2}} - \left(\frac{-3}{2} \right) \frac{2xy}{(x^2 + y^2 + z^2)^{5/2}} \right] \\
 &= 0
 \end{aligned}$$

Hence, \vec{F} is irrotational.

$\Rightarrow \vec{F} = \nabla\phi$, where ϕ is called scalar potential

$$\begin{aligned}
 \vec{F} &= \nabla\phi \\
 d\phi &= \frac{\partial\phi}{\partial x} dx + \frac{\partial\phi}{\partial y} dy + \frac{\partial\phi}{\partial z} dz \quad \text{[Total differential coefficient]} \\
 &= \left(\hat{i} \frac{\partial\phi}{\partial x} + \hat{j} \frac{\partial\phi}{\partial y} + \hat{k} \frac{\partial\phi}{\partial z} \right) \cdot (\hat{i} dx + \hat{j} dy + \hat{k} dz) = \nabla\phi \cdot d\vec{r} = \vec{F} \cdot d\vec{r} \\
 &= \frac{x\hat{i} + y\hat{j} + z\hat{k}}{(x^2 + y^2 + z^2)^{3/2}} \cdot (i dx + j dy + k dz) = \frac{x dx + y dy + z dz}{(x^2 + y^2 + z^2)^{3/2}} \\
 \phi &= \frac{1}{2} \int \frac{2x dx + 2y dy + 2z dz}{(x^2 + y^2 + z^2)^{3/2}} \\
 &= \frac{1}{2} \left(-\frac{1}{1} \right) (x^2 + y^2 + z^2)^{-1/2} = -\frac{1}{(x^2 + y^2 + z^2)^{1/2}} = -\frac{1}{|\vec{r}|} \quad \text{Ans.}
 \end{aligned}$$

Now, $\text{Div} \vec{F} = \nabla \cdot \vec{F}$

$$\begin{aligned}
 &= \left(\hat{i} \frac{\partial}{\partial x} + \hat{j} \frac{\partial}{\partial y} + \hat{k} \frac{\partial}{\partial z} \right) \cdot \frac{x\hat{i} + y\hat{j} + z\hat{k}}{(x^2 + y^2 + z^2)^{3/2}} \\
 &= \frac{\partial}{\partial x} \frac{x}{(x^2 + y^2 + z^2)^{3/2}} + \frac{\partial}{\partial y} \frac{y}{(x^2 + y^2 + z^2)^{3/2}} + \frac{\partial}{\partial z} \frac{z}{(x^2 + y^2 + z^2)^{3/2}} \\
 &= \frac{(x^2 + y^2 + z^2)^{3/2} (1) - x \left(\frac{3}{2} \right) (x^2 + y^2 + z^2)^{1/2} (2x)}{(x^2 + y^2 + z^2)^3} \\
 &\quad + \frac{(x^2 + y^2 + z^2)^{3/2} (1) - y \left(\frac{3}{2} \right) (x^2 + y^2 + z^2)^{1/2} (2y)}{(x^2 + y^2 + z^2)^3} \\
 &\quad + \frac{(x^2 + y^2 + z^2)^{3/2} (1) - z \left(\frac{3}{2} \right) (x^2 + y^2 + z^2)^{1/2} (2z)}{(x^2 + y^2 + z^2)^3}
 \end{aligned}$$

$$= \frac{(x^2 + y^2 + z^2)^{1/2}}{(x^2 + y^2 + z^2)^3} [x^2 + y^2 + z^2 - 3x^2 + x^2 + y^2 + z^2 - 3y^2 + x^2 + y^2 + z^2 - 3z^2]$$

$$= 0$$

Hence, \vec{F} is solenoidal.

Proved.

Example 53. Given the vector field $\vec{V} = (x^2 - y^2 + 2xz)\hat{i} + (xz - xy + yz)\hat{j} + (z^2 + x^2)\hat{k}$ find curl V . Show that the vectors given by curl V at $P_0(1, 2, -3)$ and $P_1(2, 3, 12)$ are orthogonal.

Solution.

$$\text{Curl } \vec{V} = \nabla \times \vec{V}$$

$$= \left(\hat{i} \frac{\partial}{\partial x} + \hat{j} \frac{\partial}{\partial y} + \hat{k} \frac{\partial}{\partial z} \right) \times [(x^2 - y^2 + 2xz)\hat{i} + (xz - xy + yz)\hat{j} + (z^2 + x^2)\hat{k}]$$

$$\text{curl } \vec{V} = \begin{vmatrix} \hat{i} & \hat{j} & \hat{k} \\ \frac{\partial}{\partial x} & \frac{\partial}{\partial y} & \frac{\partial}{\partial z} \\ x^2 - y^2 + 2xz & xz - xy + yz & z^2 + x^2 \end{vmatrix}$$

$$= -(x+y)\hat{i} - (2x-2x)\hat{j} + (z-y+2y)\hat{k} = -(x+y)\hat{i} + (y+z)\hat{k}$$

$$\text{curl } \vec{V} \text{ at } P_0(1, 2, -3) = -(1+2)\hat{i} + (-3+2)\hat{k} = -3\hat{i} - \hat{k}$$

$$\text{curl } \vec{V} \text{ at } P_1(2, 3, 12) = -(2+3)\hat{i} + (3+12)\hat{k} = -5\hat{i} + 15\hat{k}$$

The curl \vec{V} at $(1, 2, -3)$ and $(2, 3, 12)$ are perpendicular since

$$(-3\hat{i} - \hat{k}) \cdot (-5\hat{i} + 15\hat{k}) = +15 - 15 = 0$$

Proved.

Example 54. Find the constants a, b, c , so that

$$\vec{F} = (x+2y+az)\hat{i} + (bx-3y-z)\hat{j} + (4x+cy+2z)\hat{k} \quad \dots(1)$$

is irrotational and hence find function ϕ such that $\vec{F} = \nabla\phi$.

(Nagpur University, Summer 2005, Winter 2000; R.G.P.V., Bhopal 2009)

Solution. We have,

$$\nabla \times \vec{F} = \begin{vmatrix} \hat{i} & \hat{j} & \hat{k} \\ \frac{\partial}{\partial x} & \frac{\partial}{\partial y} & \frac{\partial}{\partial z} \\ x+2y+az & bx-3y-z & 4x+cy+2z \end{vmatrix}$$

$$\Rightarrow (c+1)\hat{i} - (4-a)\hat{j} + (b-2)\hat{k}$$

As \vec{F} is irrotational,

$$\nabla \times \vec{F} = 0$$

$$\text{i.e., } (c+1)\hat{i} - (4-a)\hat{j} + (b-2)\hat{k} = 0\hat{i} + 0\hat{j} + 0\hat{k}$$

$$\therefore c+1 = 0, \quad 4-a = 0 \quad \text{and} \quad b-2 = 0$$

$$\text{i.e., } a = 4, \quad b = 2, \quad c = -1$$

Putting the values of a, b, c in (1), we get

$$\vec{F} = (x+2y+4z)\hat{i} + (2x-3y-z)\hat{j} + (4x-y+2z)\hat{k}$$

Vectors

Now we have to find ϕ such that $\vec{F} = \nabla\phi$

We know that

$$d\phi = \frac{\partial\phi}{\partial x} dx + \frac{\partial\phi}{\partial y} dy + \frac{\partial\phi}{\partial z} dz \quad [\text{Total differential coefficient}]$$

$$= \left(i \frac{\partial}{\partial x} + j \frac{\partial}{\partial y} + k \frac{\partial}{\partial z} \right) \cdot (i dx + j dy + k dz)$$

$$= \left(i \frac{\partial}{\partial x} + j \frac{\partial}{\partial y} + k \frac{\partial}{\partial z} \right) \cdot \phi \cdot (i dx + j dy + k dz) = \nabla\phi \cdot (i dx + j dy + k dz)$$

$$= \vec{F} \cdot (i dx + j dy + k dz)$$

$$= [(x + 2y + 4z)i + (2x - 3y - z)j + (4x - y + 2z)k] \cdot (i dx + j dy + k dz)$$

$$= (x + 2y + 4z) dx + (2x - 3y - z) dy + (4x - y + 2z) dz$$

$$= x dx - 3y dy + 2z dz + (2y dx + 2x dy) + (4z dx + 4x dz) + (-z dy - y dz)$$

$$\phi = \int x dx - 3 \int y dy + 2 \int z dz + \int (2y dx + 2x dy) + \int (4z dx + 4x dz) - \int (z dy + y dz)$$

$$= \frac{x^2}{2} - \frac{3y^2}{2} + z^2 + 2xy + 4zx - yz + c$$

Ans.

Example 55. Let $\vec{V}(x, y, z)$ be a differentiable vector function and $\phi(x, y, z)$ be a scalar function. Derive an expression for $\text{div}(\phi\vec{V})$ in terms of $\phi \cdot \nabla \cdot \vec{V}$, $\text{div} \vec{V}$ and $\nabla\phi$.

(U.P. I Semester, Winter 2003)

Solution. Let $\vec{V} = V_1 \hat{i} + V_2 \hat{j} + V_3 \hat{k}$

$$\text{div}(\phi\vec{V}) = \nabla \cdot (\phi\vec{V}) = \left(i \frac{\partial}{\partial x} + j \frac{\partial}{\partial y} + k \frac{\partial}{\partial z} \right) \cdot (\phi V_1 \hat{i} + \phi V_2 \hat{j} + \phi V_3 \hat{k})$$

$$= \left(i \frac{\partial}{\partial x} + j \frac{\partial}{\partial y} + k \frac{\partial}{\partial z} \right) \cdot [\phi V_1 \hat{i} + \phi V_2 \hat{j} + \phi V_3 \hat{k}] = \frac{\partial}{\partial x}(\phi V_1) + \frac{\partial}{\partial y}(\phi V_2) + \frac{\partial}{\partial z}(\phi V_3)$$

$$= \left(\phi \frac{\partial V_1}{\partial x} + \frac{\partial \phi}{\partial x} V_1 \right) + \left(\phi \frac{\partial V_2}{\partial y} + \frac{\partial \phi}{\partial y} V_2 \right) + \left(\phi \frac{\partial V_3}{\partial z} + \frac{\partial \phi}{\partial z} V_3 \right)$$

$$= \phi \left(\frac{\partial V_1}{\partial x} + \frac{\partial V_2}{\partial y} + \frac{\partial V_3}{\partial z} \right) + \left(\frac{\partial \phi}{\partial x} V_1 + \frac{\partial \phi}{\partial y} V_2 + \frac{\partial \phi}{\partial z} V_3 \right)$$

$$= \phi \left(i \frac{\partial}{\partial x} + j \frac{\partial}{\partial y} + k \frac{\partial}{\partial z} \right) \cdot (V_1 \hat{i} + V_2 \hat{j} + V_3 \hat{k}) + \left(i \frac{\partial}{\partial x} + j \frac{\partial}{\partial y} + k \frac{\partial}{\partial z} \right) \cdot (\phi V_1 \hat{i} + \phi V_2 \hat{j} + \phi V_3 \hat{k})$$

$$= \phi(\nabla \cdot \vec{V}) + (\nabla\phi) \cdot \vec{V} = \phi(\text{div} \vec{V}) + (\text{grad} \phi) \cdot \vec{V}$$

Ans.

Example 56. If \vec{A} is a constant vector and $\vec{R} = x\hat{i} + y\hat{j} + z\hat{k}$, then prove that

$$\text{Curl} \left[\left(\vec{A} \cdot \vec{R} \right) \vec{A} \right] = \vec{A} \times \vec{R} \quad (\text{K. University, Dec. 2009})$$

Solution. Let $\vec{A} = A_1 \hat{i} + A_2 \hat{j} + A_3 \hat{k}$, $\vec{R} = x\hat{i} + y\hat{j} + z\hat{k}$

$$\vec{A} \cdot \vec{R} = (A_1 \hat{i} + A_2 \hat{j} + A_3 \hat{k}) \cdot (x\hat{i} + y\hat{j} + z\hat{k}) = A_1 x + A_2 y + A_3 z$$

$$\vec{A} \cdot \vec{R} = \frac{1}{1} (A_1 x^2 + A_2 y^2 + A_3 z^2) (x\hat{i} + y\hat{j} + z\hat{k})$$

$$= (A_1 x^2 + A_2 xy + A_3 zx) \hat{i} + (A_1 xy + A_2 y^2 + A_3 yz) \hat{j} + (A_1 xz + A_2 yz + A_3 z^2) \hat{k}$$

Vectors

$$\text{Curl} \begin{vmatrix} \vec{i} & \vec{j} & \vec{k} \\ \frac{\partial}{\partial x} & \frac{\partial}{\partial y} & \frac{\partial}{\partial z} \\ A_1x^2 + A_2xy + A_3zx & A_2xy + A_2y^2 + A_3yz & A_1xz + A_2yz + A_3z^2 \end{vmatrix} = (A_2z - A_3y) \vec{i} - [A_1z - A_3x] \vec{j} + [A_1y - A_2x] \vec{k} \quad \dots (1)$$

$$\begin{aligned} \text{L.H.S.} &= \vec{A} \times \vec{R} \\ &= (A_1\vec{i} + A_2\vec{j} + A_3\vec{k}) \times (x\vec{i} + y\vec{j} + z\vec{k}) \\ &= \begin{vmatrix} \vec{i} & \vec{j} & \vec{k} \\ A_1 & A_2 & A_3 \\ x & y & z \end{vmatrix} \\ &= (A_2z - A_3y) \vec{i} - (A_1z - A_3x) \vec{j} + (A_1y - A_2x) \vec{k} \\ &= \text{R.H.S.} \end{aligned} \quad [\text{From (1)}]$$

Example 57. Suppose that \vec{U}, \vec{V} and f are continuously differentiable fields then Prove that, $\text{div} (\vec{U} \times \vec{V}) = \vec{V} \cdot \text{curl} \vec{U} - \vec{U} \cdot \text{curl} \vec{V}$. (M.U. 2003, 2005)

Solution. Let $\vec{U} = u_1\vec{i} + u_2\vec{j} + u_3\vec{k}, \vec{V} = v_1\vec{i} + v_2\vec{j} + v_3\vec{k}$

$$\vec{U} \times \vec{V} = \begin{vmatrix} \vec{i} & \vec{j} & \vec{k} \\ u_1 & u_2 & u_3 \\ v_1 & v_2 & v_3 \end{vmatrix}$$

$$\begin{aligned} \text{div} (\vec{U} \times \vec{V}) &= \left(\frac{\partial}{\partial x} (u_2v_3 - u_3v_2) + \frac{\partial}{\partial y} (u_3v_1 - u_1v_3) + \frac{\partial}{\partial z} (u_1v_2 - u_2v_1) \right) \\ &= \left[\frac{\partial}{\partial x} (u_2v_3 - u_3v_2) + \frac{\partial}{\partial y} (-u_1v_3 + u_3v_1) + \frac{\partial}{\partial z} (u_1v_2 - u_2v_1) \right] \\ &= \left[u_2 \frac{\partial v_3}{\partial x} + v_3 \frac{\partial u_2}{\partial x} - u_3 \frac{\partial v_2}{\partial x} - v_2 \frac{\partial u_3}{\partial x} \right] + \left[-u_1 \frac{\partial v_3}{\partial y} - v_3 \frac{\partial u_1}{\partial y} + u_3 \frac{\partial v_1}{\partial y} + v_1 \frac{\partial u_3}{\partial y} \right] \\ &\quad + \left[u_1 \frac{\partial v_2}{\partial z} + v_2 \frac{\partial u_1}{\partial z} - u_2 \frac{\partial v_1}{\partial z} - v_1 \frac{\partial u_2}{\partial z} \right] \\ &= v_1 \left(\frac{\partial u_3}{\partial y} - \frac{\partial u_2}{\partial z} \right) + v_2 \left(-\frac{\partial u_3}{\partial x} + \frac{\partial u_1}{\partial z} \right) + v_3 \left(\frac{\partial u_2}{\partial x} - \frac{\partial u_1}{\partial y} \right) \\ &\quad + u_1 \left(-\frac{\partial v_3}{\partial y} + \frac{\partial v_2}{\partial z} \right) + u_2 \left(\frac{\partial v_3}{\partial x} - \frac{\partial v_1}{\partial z} \right) + u_3 \left(\frac{\partial v_1}{\partial y} - \frac{\partial v_2}{\partial x} \right) \\ &= (v_1\vec{i} + v_2\vec{j} + v_3\vec{k}) \cdot \left[\vec{i} \left(\frac{\partial u_3}{\partial y} - \frac{\partial u_2}{\partial z} \right) + \vec{j} \left(\frac{\partial u_1}{\partial z} - \frac{\partial u_3}{\partial x} \right) + \vec{k} \left(\frac{\partial u_2}{\partial x} - \frac{\partial u_1}{\partial y} \right) \right] \\ &\quad - (u_1\vec{i} + u_2\vec{j} + u_3\vec{k}) \cdot \left[\vec{i} \left(-\frac{\partial v_2}{\partial z} + \frac{\partial v_3}{\partial y} \right) + \vec{j} \left(-\frac{\partial v_3}{\partial x} + \frac{\partial v_1}{\partial z} \right) + \vec{k} \left(-\frac{\partial v_1}{\partial y} + \frac{\partial v_2}{\partial x} \right) \right] \\ &= \vec{V} \cdot (\nabla \times \vec{U}) - \vec{U} \cdot (\nabla \times \vec{V}) = \vec{V} \cdot \text{curl} \vec{U} - \vec{U} \cdot \text{curl} \vec{V} \end{aligned}$$

Proved.

Vectors

Example 58. Prove that

$$\nabla \times (F \times G) = F(\nabla \cdot G) - G(\nabla \cdot F) + (G \cdot \nabla)F - (F \cdot \nabla)G \quad (M.U. 2004, 2005)$$

Solution.

$$\begin{aligned} \nabla \times (F \times G) &= \sum_i \hat{e}_i \times (\nabla \times (F \times G)) \\ &= \sum_i \hat{e}_i \times (\partial_j F_k - \partial_k F_j) \times (G_l - G_m) \\ &= \sum_i \hat{e}_i \times (\partial_j F_k G_l - \partial_k F_j G_l - \partial_j F_k G_m + \partial_k F_j G_m) \\ &= \sum_i \hat{e}_i \times (\partial_j F_k G_l - \partial_k F_j G_l) + \sum_i \hat{e}_i \times (\partial_j F_k G_m - \partial_k F_j G_m) \\ &= \sum_i \hat{e}_i \times (\partial_j F_k G_l - \partial_k F_j G_l) + \sum_i \hat{e}_i \times (\partial_j F_k G_m - \partial_k F_j G_m) \\ &= \sum_i \hat{e}_i \times (\partial_j F_k G_l - \partial_k F_j G_l) + \sum_i \hat{e}_i \times (\partial_j F_k G_m - \partial_k F_j G_m) \\ &= F(\nabla \cdot G) - G(\nabla \cdot F) + (G \cdot \nabla)F - (F \cdot \nabla)G \end{aligned}$$

Proved.

Questions for practice:

Prove that

$$\nabla (F \cdot G) = (G \cdot \nabla)F + (F \cdot \nabla)G + G \times (\nabla \times F) + F \times (\nabla \times G)$$

Example 59. Prove that, for every field \vec{V} ; $\text{div curl } \vec{V} = 0$.

(Nagpur University, Summer 2004; AMIETE, Sem II, June 2010)

Solution. Let

$$V = V_1 \hat{i} + V_2 \hat{j} + V_3 \hat{k}$$

$$\begin{aligned} \text{div (curl } V) &= \nabla \cdot (\nabla \times V) \\ &= \nabla \cdot \left(\hat{i} \left(\frac{\partial V_3}{\partial y} - \frac{\partial V_2}{\partial z} \right) + \hat{j} \left(\frac{\partial V_1}{\partial z} - \frac{\partial V_3}{\partial x} \right) + \hat{k} \left(\frac{\partial V_2}{\partial x} - \frac{\partial V_1}{\partial y} \right) \right) \\ &= \left(\frac{\partial}{\partial x} \left(\frac{\partial V_3}{\partial y} - \frac{\partial V_2}{\partial z} \right) + \frac{\partial}{\partial y} \left(\frac{\partial V_1}{\partial z} - \frac{\partial V_3}{\partial x} \right) + \frac{\partial}{\partial z} \left(\frac{\partial V_2}{\partial x} - \frac{\partial V_1}{\partial y} \right) \right) \\ &= \frac{\partial^2 V_3}{\partial x \partial y} - \frac{\partial^2 V_2}{\partial x \partial z} + \frac{\partial^2 V_1}{\partial y \partial z} - \frac{\partial^2 V_3}{\partial y \partial x} + \frac{\partial^2 V_1}{\partial z \partial x} - \frac{\partial^2 V_2}{\partial z \partial y} + \frac{\partial^2 V_2}{\partial z \partial x} - \frac{\partial^2 V_1}{\partial z \partial y} \\ &= 0 \end{aligned}$$

Ans.

Example 60. If \vec{a} is a constant vector, show that

$$\vec{a} \times (\nabla \times \vec{r}) = \nabla (\vec{a} \cdot \vec{r}) - (\vec{a} \cdot \nabla) \vec{r} \quad (U.P., Ist Semester, Dec. 2007)$$

Solution.

$$\vec{a} = a_1 \hat{i} + a_2 \hat{j} + a_3 \hat{k}, \quad \vec{r} = r_1 \hat{i} + r_2 \hat{j} + r_3 \hat{k}$$

Vectors

$$\vec{\nabla} \times \vec{r} = \begin{vmatrix} \hat{i} & \hat{j} & \hat{k} \\ \frac{\partial}{\partial x} & \frac{\partial}{\partial y} & \frac{\partial}{\partial z} \\ r_1 & r_2 & r_3 \end{vmatrix} = \left(\frac{\partial r_3}{\partial y} - \frac{\partial r_2}{\partial z} \right) \hat{i} - \left(\frac{\partial r_3}{\partial x} - \frac{\partial r_1}{\partial z} \right) \hat{j} + \left(\frac{\partial r_2}{\partial x} - \frac{\partial r_1}{\partial y} \right) \hat{k}$$

$$\vec{a} \times (\vec{\nabla} \times \vec{r}) = \begin{vmatrix} \hat{i} & \hat{j} & \hat{k} \\ a_1 & a_2 & a_3 \\ \frac{\partial r_3}{\partial y} - \frac{\partial r_2}{\partial z} & -\frac{\partial r_3}{\partial x} + \frac{\partial r_1}{\partial z} & \frac{\partial r_2}{\partial x} - \frac{\partial r_1}{\partial y} \end{vmatrix}$$

$$= \left[\left(a_2 \frac{\partial r_2}{\partial x} - a_2 \frac{\partial r_1}{\partial y} \right) - \left(a_3 \frac{\partial r_3}{\partial x} + a_3 \frac{\partial r_1}{\partial z} \right) \right] \hat{i} - \left[a_1 \frac{\partial r_2}{\partial x} - a_1 \frac{\partial r_1}{\partial y} - a_3 \frac{\partial r_3}{\partial y} + a_3 \frac{\partial r_2}{\partial z} \right] \hat{j}$$

$$+ \left[-a_1 \frac{\partial r_3}{\partial x} + a_1 \frac{\partial r_1}{\partial z} - a_2 \frac{\partial r_3}{\partial y} + a_2 \frac{\partial r_2}{\partial z} \right] \hat{k}$$

$$= \left[\left(a_1 \hat{i} \frac{\partial r_1}{\partial x} + a_2 \hat{i} \frac{\partial r_2}{\partial x} + a_3 \hat{i} \frac{\partial r_3}{\partial x} \right) + \left(a_1 \hat{j} \frac{\partial r_1}{\partial y} + a_2 \hat{j} \frac{\partial r_2}{\partial y} + a_3 \hat{j} \frac{\partial r_3}{\partial y} \right) \right]$$

$$+ \left[a_1 \hat{k} \frac{\partial r_1}{\partial z} + a_2 \hat{k} \frac{\partial r_2}{\partial z} + a_3 \hat{k} \frac{\partial r_3}{\partial z} \right] - \left[\left(a_1 \hat{i} \frac{\partial r_1}{\partial x} + a_1 \hat{j} \frac{\partial r_2}{\partial x} + a_1 \hat{k} \frac{\partial r_3}{\partial x} \right) \right]$$

$$+ \left[\left(a_2 \hat{i} \frac{\partial r_1}{\partial y} + a_2 \hat{j} \frac{\partial r_2}{\partial y} + a_2 \hat{k} \frac{\partial r_3}{\partial y} \right) + \left(a_3 \hat{i} \frac{\partial r_1}{\partial z} + a_3 \hat{j} \frac{\partial r_2}{\partial z} + a_3 \hat{k} \frac{\partial r_3}{\partial z} \right) \right]$$

$$= \left(\hat{i} \frac{\partial}{\partial x} + \hat{j} \frac{\partial}{\partial y} + \hat{k} \frac{\partial}{\partial z} \right) (a_1 r_1 + a_2 r_2 + a_3 r_3) - \left[a_1 \frac{\partial}{\partial x} + a_2 \frac{\partial}{\partial y} + a_3 \frac{\partial}{\partial z} \right] (r_1 \hat{i} + r_2 \hat{j} + r_3 \hat{k})$$

$$= \vec{\nabla}(\vec{a} \cdot \vec{r}) - (\vec{a} \cdot \vec{\nabla}) \vec{r}$$

Proved.

Example 61. If r is the distance of a point (x, y, z) from the origin, prove that $\text{Curl} \left(k \times \text{grad} \frac{1}{r} \right) + \text{grad} \left(k \cdot \text{grad} \frac{1}{r} \right) = 0$, where k is the unit vector in the direction OZ. (U.P., I Semester, Winter 2000)

Solution.

$$r^2 = (x - 0)^2 + (y - 0)^2 + (z - 0)^2 = x^2 + y^2 + z^2$$

$$\Rightarrow \frac{1}{r} = (x^2 + y^2 + z^2)^{-1/2}$$

$$\text{grad} \frac{1}{r} = \nabla \frac{1}{r} = \left(\hat{i} \frac{\partial}{\partial x} + \hat{j} \frac{\partial}{\partial y} + \hat{k} \frac{\partial}{\partial z} \right) (x^2 + y^2 + z^2)^{-1/2}$$

$$= \frac{-1}{2} (x^2 + y^2 + z^2)^{-3/2} (2x\hat{i} + 2y\hat{j} + 2z\hat{k})$$

$$= -(x^2 + y^2 + z^2)^{-3/2} (x\hat{i} + y\hat{j} + z\hat{k})$$

$$k \times \text{grad} \frac{1}{r} = k \times [-(x^2 + y^2 + z^2)^{-3/2} (x\hat{i} + y\hat{j} + z\hat{k})]$$

$$= -(x^2 + y^2 + z^2)^{-3/2} (\hat{k} \times (x\hat{i} + y\hat{j} + z\hat{k}))$$

$$= -(x^2 + y^2 + z^2)^{-3/2} (x\hat{j} - y\hat{i})$$

$$\text{curl} \left(k \times \text{grad} \frac{1}{r} \right) = \nabla \times \left(k \times \text{grad} \frac{1}{r} \right)$$

Vectors

$$\begin{aligned}
 &= \left(\hat{i} \frac{\partial}{\partial x} + \hat{j} \frac{\partial}{\partial y} + \hat{k} \frac{\partial}{\partial z} \right) \times [-(x^2 + y^2 + z^2)^{-3/2} (x\hat{j} - y\hat{i})] \\
 &= \begin{vmatrix} \hat{i} & \hat{j} & \hat{k} \\ \frac{\partial}{\partial x} & \frac{\partial}{\partial y} & \frac{\partial}{\partial z} \\ \frac{y}{(x^2 + y^2 + z^2)^{3/2}} & \frac{-x}{(x^2 + y^2 + z^2)^{3/2}} & 0 \end{vmatrix} \\
 &= \left(\frac{-3}{2} \right) \frac{(-x)(2z)}{(x^2 + y^2 + z^2)^{5/2}} \hat{i} + \left(\frac{-3}{2} \right) \frac{y(2z)}{(x^2 + y^2 + z^2)^{5/2}} \hat{j} + \left[\frac{-3}{2} \frac{(-x)(2x)}{(x^2 + y^2 + z^2)^{5/2}} \right] \hat{k} \\
 &= \frac{-3xz}{(x^2 + y^2 + z^2)^{5/2}} \hat{i} - \frac{3yz}{(x^2 + y^2 + z^2)^{5/2}} \hat{j} + \frac{(3x^2 - x^2 - y^2 - z^2 + 3y^2 - x^2 - y^2 - z^2 + 3z^2)}{(x^2 + y^2 + z^2)^{5/2}} \hat{k} \\
 &= \frac{-3xz \hat{i} - 3yz \hat{j} + (x^2 + y^2 - 2z^2) \hat{k}}{(x^2 + y^2 + z^2)^{5/2}} \quad \dots(1)
 \end{aligned}$$

$$\begin{aligned}
 k \cdot \text{grad} \frac{1}{r} &= k \cdot [-(x^2 + y^2 + z^2)^{-3/2} (\hat{x}i + \hat{y}j + \hat{z}k)] = \frac{-z}{(x^2 + y^2 + z^2)^{3/2}} \\
 \text{grad} \left(k \cdot \text{grad} \frac{1}{r} \right) &= \left[\hat{i} \frac{\partial}{\partial x} + \hat{j} \frac{\partial}{\partial y} + \hat{k} \frac{\partial}{\partial z} \right] \frac{-z}{(x^2 + y^2 + z^2)^{3/2}} \\
 &= -\frac{3}{2} \frac{\hat{i}(-z)(2x)}{(x^2 + y^2 + z^2)^{5/2}} + -\frac{3}{2} \frac{\hat{j}(-z)(2y)}{(x^2 + y^2 + z^2)^{5/2}} + \left[-\frac{3}{2} \frac{(-z)(2z)}{(x^2 + y^2 + z^2)^{5/2}} - \frac{1}{(x^2 + y^2 + z^2)^{3/2}} \right] \hat{k} \\
 &= \frac{3xz \hat{i} + 3yz \hat{j} + (3z^2 - x^2 - y^2 - z^2) \hat{k}}{(x^2 + y^2 + z^2)^{5/2}} = \frac{3xz \hat{i} + 3yz \hat{j} - (x^2 + y^2 - 2z^2) \hat{k}}{(x^2 + y^2 + z^2)^{5/2}} \quad \dots(2)
 \end{aligned}$$

Adding (1) and (2), we get

$$\text{Curl} \left(k \times \text{grad} \frac{1}{r} \right) + \text{grad} \left(k \cdot \text{grad} \frac{1}{r} \right) = 0 \quad \text{Proved.}$$

Example 62. Prove that $\nabla \times \left(\frac{\vec{a} \times \vec{r}}{r^n} \right) = \frac{(2-n)\vec{a}}{r^n} + \frac{n(\vec{a} \cdot \vec{r})\vec{r}}{r^{n+2}}$.

(M.U. 2009, 2005, 2003, 2002; AMIETE, II Sem. June 2010)

Solution. We have,

$$\begin{aligned}
 \frac{\vec{a} \times \vec{r}}{r^n} &= \frac{1}{r^n} \begin{vmatrix} \hat{i} & \hat{j} & \hat{k} \\ a_1 & a_2 & a_3 \\ x & y & z \end{vmatrix} \\
 &= \frac{1}{r^n} (a_2 z - a_3 y) \hat{i} + \frac{1}{r^n} (a_3 x - a_1 z) \hat{j} + \frac{1}{r^n} (a_1 y - a_2 x) \hat{k}
 \end{aligned}$$

$$\nabla \times \frac{(\vec{a} \times \vec{r})}{r^n} = \begin{vmatrix} \hat{i} & \hat{j} & \hat{k} \\ \frac{\partial}{\partial x} & \frac{\partial}{\partial y} & \frac{\partial}{\partial z} \\ \frac{a_2z - a_3y}{r^n} & \frac{a_3x - a_1z}{r^n} & \frac{a_1y - a_2x}{r^n} \end{vmatrix}$$

$$= \hat{i} \left[\frac{\partial}{\partial y} \left(\frac{a_1y - a_2x}{r^n} \right) - \frac{\partial}{\partial z} \left(\frac{a_3x - a_1z}{r^n} \right) \right] - \hat{j} \left[\frac{\partial}{\partial x} \left(\frac{a_1y - a_2x}{r^n} \right) - \frac{\partial}{\partial z} \left(\frac{a_2z - a_3y}{r^n} \right) \right]$$

$$+ \hat{k} \left[\frac{\partial}{\partial x} \left(\frac{a_3x - a_1z}{r^n} \right) - \frac{\partial}{\partial y} \left(\frac{a_2z - a_3y}{r^n} \right) \right]$$

Now, $r^2 = x^2 + y^2 + z^2 \Rightarrow 2r \frac{\partial r}{\partial x} = 2x \Rightarrow \frac{\partial r}{\partial x} = \frac{x}{r}$

Similarly, $\frac{\partial r}{\partial y} = \frac{y}{r}, \frac{\partial r}{\partial z} = \frac{z}{r}$

$$\therefore \nabla \times \left(\frac{\vec{a} \times \vec{r}}{r^n} \right) = \hat{i} \left[-nr^{-n-1} \left(\frac{y}{r} \right) (a_1y - a_2x) + \frac{1}{r^n} a_1 \right]$$

$$- \left[-nr^{-n-1} \left(\frac{z}{r} \right) (a_3x - a_1z) + \frac{1}{r^n} (-a_1) \right] + \text{two similar terms}$$

$$= \hat{i} \left[\frac{2a_1}{r^{n+2}} (a_1y - a_2xy) + \frac{n}{r^n} + \frac{1}{r^{n+2}} (a_3xz - a_1z) + \frac{1}{r^n} \right] + \text{two similar terms}$$

$$= \hat{i} \left[\frac{2a_1}{r^{n+2}} - \frac{na_1}{r^{n+2}} (y^2 + z^2) + \frac{n}{r^{n+2}} (a_1xy + a_2xz) \right] + \text{two similar terms}$$

Adding and subtracting $\frac{na_1}{r^{n+2}} x^2$ to third and from second term, we get

$$\vec{\nabla} \times \left(\frac{\vec{a} \times \vec{r}}{r^n} \right) = \hat{i} \left[\frac{2a_1}{r^{n+2}} - \frac{na_1}{r^{n+2}} (x^2 + y^2 + z^2) + \frac{n}{r^{n+2}} (a_1x^2 + a_2xy + a_3xz) \right]$$

$$+ \text{two similar terms}$$

$$= \hat{i} \left[\frac{2a_1}{r^{n+2}} - \frac{na_1}{r^{n+2}} r^2 + \frac{n}{r^{n+2}} x(a_1x + a_2y + a_3z) \right] + \text{two similar terms}$$

$$= \hat{i} \left[\frac{2a_1}{r^n} - \frac{na_1}{r^n} + \frac{n}{r^{n+2}} x(a_1x + a_2y + a_3z) \right] + \hat{j} \left[\frac{2a_2}{r^n} - \frac{na_2}{r^n} + \frac{n}{r^{n+2}} y(a_2y + a_3z + a_1x) \right]$$

$$+ \hat{k} \left[\frac{2a_3}{r^n} - \frac{na_3}{r^n} + \frac{n}{r^{n+2}} z(a_3z + a_1x + a_2y) \right]$$

$$= \frac{2-n}{r^n} (a_1\hat{i} + a_2\hat{j} + a_3\hat{k}) - \frac{n}{r^n} (a_1\hat{i} + a_2\hat{j} + a_3\hat{k}) + \frac{n}{r^{n+2}} (a_1x + a_2y + a_3z) (\hat{i}x + \hat{j}y + \hat{k}z)$$

$$= \frac{2-n}{r^n} (a_1\hat{i} + a_2\hat{j} + a_3\hat{k}) + \frac{n}{r^{n+2}} (a_1x + a_2y + a_3z) (\hat{i}x + \hat{j}y + \hat{k}z)$$

$$= \frac{2-n}{r^n} a + \frac{n}{r^{n+2}} (a \cdot r) r$$

Proved.

Example 63. If f and g are two scalar point functions, prove that

$$\text{div} (f \nabla g) = f \nabla^2 g + \nabla f \cdot \nabla g. \quad (\text{U.P., I Semester, compartment, Winter 2001})$$

Vectors

Solution. We have, $\nabla g = \frac{\partial g}{\partial x} \hat{i} + \frac{\partial g}{\partial y} \hat{j} + \frac{\partial g}{\partial z} \hat{k}$

$$\Rightarrow f \nabla g = f \frac{\partial g}{\partial x} \hat{i} + f \frac{\partial g}{\partial y} \hat{j} + f \frac{\partial g}{\partial z} \hat{k}$$

$$\Rightarrow \text{div} (f \nabla g) = \frac{\partial}{\partial x} \left(f \frac{\partial g}{\partial x} \right) + \frac{\partial}{\partial y} \left(f \frac{\partial g}{\partial y} \right) + \frac{\partial}{\partial z} \left(f \frac{\partial g}{\partial z} \right)$$

$$= f \left(\frac{\partial^2 g}{\partial x^2} + \frac{\partial^2 g}{\partial y^2} + \frac{\partial^2 g}{\partial z^2} \right) + \left(\frac{\partial f}{\partial x} \frac{\partial g}{\partial x} + \frac{\partial f}{\partial y} \frac{\partial g}{\partial y} + \frac{\partial f}{\partial z} \frac{\partial g}{\partial z} \right)$$

$$= f \left(\frac{\partial^2}{\partial x^2} + \frac{\partial^2}{\partial y^2} + \frac{\partial^2}{\partial z^2} \right) g + \left(\frac{\partial f}{\partial x} \hat{i} + \frac{\partial f}{\partial y} \hat{j} + \frac{\partial f}{\partial z} \hat{k} \right) \cdot \left(\frac{\partial g}{\partial x} \hat{i} + \frac{\partial g}{\partial y} \hat{j} + \frac{\partial g}{\partial z} \hat{k} \right)$$

$$= f \nabla^2 g + \nabla f \cdot \nabla g \quad \text{Proved.}$$

Example 64. For a solenoidal vector \vec{F} , show that $\text{curl curl curl curl } \vec{F} = \nabla^4 \vec{F}$.
(M.D.U., Dec. 2009)

Solution. Since vector \vec{F} is solenoidal, so $\text{div } \vec{F} = 0$... (1)

We know that $\text{curl curl } \vec{F} = \text{grad div } (\vec{F}) - \nabla^2 \vec{F}$... (2)

Using (1) in (2), $\text{grad div } \vec{F} = \text{grad} (0) = 0$... (3)

On putting the value of $\text{grad div } \vec{F}$ in (2), we get

$\text{curl curl } \vec{F} = -\nabla^2 \vec{F}$... (4)

Now, $\text{curl curl curl curl } \vec{F} = \text{curl curl} (-\nabla^2 \vec{F})$ [Using (4)]

$= -\text{curl curl} (\nabla^2 \vec{F}) = -[\text{grad div} (\nabla^2 \vec{F}) - \nabla^2 (\nabla^2 \vec{F})]$ [Using (2)]

$= -\text{grad} (\nabla \cdot \nabla^2 \vec{F}) + \nabla^2 (\nabla^2 \vec{F}) = -\text{grad} (\nabla \cdot \nabla^2 \vec{F}) + \nabla^4 \vec{F}$ [Using (1)]

$= 0 + \nabla^4 \vec{F} = \nabla^4 \vec{F}$ [Using (1)] **Proved.**

EXERCISE 5.9

1. Find the divergence and curl of the vector field $V = (x^2 - y^2) \hat{i} + 2xy \hat{j} + (y^2 - xy) \hat{k}$.

Ans. Divergence = $4x$, Curl = $(2y - x) \hat{i} + y \hat{j} + 4y \hat{k}$

2. If a is constant vector and r is the radius vector, prove that

(i) $\nabla \cdot (\vec{a} \cdot \vec{r}) = \vec{a} \cdot \nabla$ (ii) $\text{div} (\vec{r} \times \vec{a}) = 0$ (iii) $\text{curl} (\vec{r} \times \vec{a}) = -2 \vec{a}$

where $\vec{r} = x \hat{i} + y \hat{j} + z \hat{k}$ and $\vec{a} = a_1 \hat{i} + a_2 \hat{j} + a_3 \hat{k}$.

3. Prove that:

(i) $\nabla \cdot (\phi A) = \nabla \phi \cdot A + \phi (\nabla \cdot A)$

(ii) $\nabla (A \cdot B) = (A \cdot \nabla) B + (B \cdot \nabla) A + A \times (\nabla \times B) + B \times (\nabla \times A)$ (R.G.P.V. Bhopal, June 2004)

(iii) $\nabla \times (A \times B) = (B \cdot \nabla) A - B (\nabla \cdot A) - (A \cdot \nabla) B + A (\nabla \cdot B)$

4. If $F = (x + y + 1) \hat{i} + \hat{j} - (x + y) \hat{k}$, show that $F \cdot \text{curl } F = 0$.
(R.G.P.V. Bhopal, Feb. 2006, June 2004)

Prove that

5. $\nabla \times (\phi F) = (\nabla \phi) \times F + \phi (\nabla \times F)$ 6. $\nabla \cdot (\vec{F} \times \vec{G}) = \vec{G} \cdot (\nabla \times \vec{F}) - \vec{F} \cdot (\nabla \times \vec{G})$

7. Evaluate $\text{div} (\vec{A} \times \vec{r})$ if $\text{curl } \vec{A} = 0$. 8. Prove that $\text{curl} (\vec{a} \times \vec{r}) = 2\vec{a}$

Vectors

9. Find $\text{div } \vec{F}$ and $\text{curl } F$ where $F = \text{grad}(x^3 + y^3 + z^3 - 3xyz)$. (R.G.P.V. Bhopal Dec. 2003)

$$\text{Ans. } \text{div } \vec{F} = 6(x + y + z), \text{ curl } \vec{F} = \vec{0}$$

10. Find out values of a, b, c for which $\vec{v} = (x + y + az)\hat{i} + (bx + 3y - z)\hat{j} + (3x + cy + z)\hat{k}$ is irrotational.

$$\text{Ans. } a = 3, b = 1, c = -1$$

11. Determine the constants a, b, c , so that $\vec{F} = (x + 2y + az)\hat{i} + (bx - 3y - z)\hat{j} + (4x + cy + 2z)\hat{k}$ is irrotational. Hence find the scalar potential ϕ such that $\vec{F} = \text{grad } \phi$.

$$(R.G.P.V. Bhopal, Feb. 2005) \text{ Ans. } a = 4, b = 2, c = 1$$

$$\text{Potential } \phi = \left(\frac{x^2}{2} - \frac{3y^2}{2} + z^2 + 2xy - yz + 4zx \right)$$

Choose the correct alternative:

12. The magnitude of the vector drawn in a direction perpendicular to the surface $x^2 + 2y^2 + z^2 = 7$ at the point $(1, -1, 2)$ is

- (i) $\frac{2}{3}$ (ii) $\frac{3}{2}$ (iii) 3 (iv) 6 (A.M.I.E.T.E., Summer 2000) Ans. (iv)

13. If $u = x^2 - y^2 + z^2$ and $\vec{V} = x\hat{i} + y\hat{j} + z\hat{k}$ then $\nabla(u\vec{V})$ is equal to

- (i) $5u$ (ii) $5|\vec{V}|$ (iii) $5(u - |\vec{V}|)$ (iv) $5(u - |\vec{V}|)$ (A.M.I.E.T.E., June 2007)

14. A unit normal to $x^2 + y^2 + z^2 = 5$ at $(0, 1, 2)$ is equal to

- (i) $\frac{1}{\sqrt{5}}(\hat{i} + \hat{j} + \hat{k})$ (ii) $\frac{1}{\sqrt{5}}(\hat{i} + \hat{j} - \hat{k})$ (iii) $\frac{1}{\sqrt{5}}(\hat{j} + 2\hat{k})$ (iv) $\frac{1}{\sqrt{5}}(\hat{i} - \hat{j} + \hat{k})$
(A.M.I.E.T.E., Dec. 2008)

15. The directional derivative of $\phi = xyz$ at the point $(1, 1, 1)$ in the direction \hat{i} is:

- (i) -1 (ii) $-\frac{1}{3}$ (iii) 1 (iv) $\frac{1}{3}$ Ans. (iii)
(R.G.P.V. Bhopal, II Sem., June 2007)

16. If $\vec{r} = x\hat{i} + y\hat{j} + z\hat{k}$ and $r = |\vec{r}|$ then $\nabla\phi(r)$ is:

- (i) $\phi'(r)\frac{\vec{r}}{r}$ (ii) $\frac{\phi(r)\vec{r}}{r}$ (iii) $\frac{\phi'(r)\vec{r}}{r}$ (iv) None of these Ans. (iii)
(R.G.P.V. Bhopal, II Semester, Feb. 2006)

17. If $\vec{r} = x\hat{i} + y\hat{j} + z\hat{k}$ is position vector, then value of $\nabla(\log r)$ is (U.P., I Sem, Dec 2008)

- (i) $\frac{\vec{r}}{r}$ (ii) $\frac{\vec{r}}{r^2}$ (iii) $-\frac{\vec{r}}{r^3}$ (iv) none of the above. Ans. (ii)

18. If $\vec{r} = x\hat{i} + y\hat{j} + z\hat{k}$ and $|\vec{r}| = r$, then $\text{div } \frac{\vec{r}}{r}$ is:

- (i) 2 (ii) 3 (iii) -3 (iv) -2 Ans. (ii)
(R.G.P.V. Bhopal, II Semester, Feb. 2006)

19. If $\vec{V} = x^2\hat{i} + 2yx\hat{j} - 2xz\hat{k}$ then $\text{curl } \vec{V}$ at point $(1, -1, 1)$ is

- (i) $-(j + 2k)$ (ii) $(i + 3k)$ (iii) $-(i + 2k)$ (iv) $(i + 2j + k)$
(R.G.P.V. Bhopal, II Semester, Feb 2006)
Ans. (iii)

20. If \vec{A} is such that $\nabla \times \vec{A} = \vec{0}$ then \vec{A} is called

- (i) Irrotational (ii) Solenoidal (iii) Rotational (iv) None of these
(A.M.I.E.T.E., Dec. 2008)

21. If \vec{F} is a conservative force field, then the value of $\text{curl } \vec{F}$ is

- (i) 0 (ii) 1 (iii) ∇F (iv) -1 (A.M.I.E.T.E., June 2007)

UNIT-5

VECTOR INTEGRATION

LINE INTEGRAL

Let $\vec{F}(x, y, z)$ be a vector function and a curve AB .

Line integral of a vector function \vec{F} along the curve AB is defined as integral of the component of \vec{F} along the tangent to the curve AB .

Component of \vec{F} along a tangent PT at P

= Dot product of \vec{F} and unit vector along PT

$$= \vec{F} \cdot \frac{d\vec{r}}{ds} \left(\frac{d\vec{r}}{ds} \text{ is a unit vector along tangent } PT \right)$$

$$\rightarrow d\vec{r}$$

Line integral = $\sum F \cdot \frac{ds}{ds}$ from A to B along the curve

$$\therefore \text{Line integral} = \int_c \left(\vec{F} \cdot \frac{d\vec{r}}{ds} \right) ds = \int_c \vec{F} \cdot d\vec{r}$$

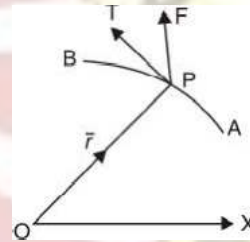

Note (1) Work. If F represents the variable force acting on a particle along arc AB , then the total work done = $\int_A^B \vec{F} \cdot d\vec{r}$

(2) Circulation. If \vec{v} represents the velocity of a liquid then $\int_c \vec{v} \cdot d\vec{r}$ is called the circulation of V round the closed curve c .

If the circulation of V round every closed curve is zero then V is said to be irrotational there.

(3) When the path of integration is a closed curve then notation of integration is \oint in place of \int .

Example 65. If a force $\vec{F} = 2x^2y\hat{i} + 3xy\hat{j}$ displaces a particle in the xy -plane from $(0, 0)$ to $(1, 4)$ along a curve $y = 4x^2$. Find the work done.

Solution. Work done = $\int_c \vec{F} \cdot d\vec{r}$

$$= \int_c (2x^2y\hat{i} + 3xy\hat{j}) \cdot (dx\hat{i} + dy\hat{j})$$

$$= \int_c (2x^2y dx + 3xy dy)$$

$$\left[\begin{array}{l} \vec{r} = x\hat{i} + y\hat{j} \\ dr = dx\hat{i} + dy\hat{j} \end{array} \right]$$

Vectors

$$\begin{pmatrix} y = 4x^2 \\ dy = 8x dx \end{pmatrix}$$

Putting the values of y and dy , we get

$$\begin{aligned} &= \int_0^1 [2x^2 (4x^2) dx + 3x (4x^2) 8x dx] \\ &= 104 \int_0^1 x^4 dx = 104 \left[\frac{x^5}{5} \right]_0^1 = \frac{104}{5} \end{aligned}$$

Ans.

Example 66. Evaluate $\int_C F \cdot dr$ where $F = x \hat{i} + xy \hat{j}$ and C is the boundary of the square in the plane $z = 0$ and bounded by the lines $x = 0, y = 0, x = a$ and $y = a$.

(Nagpur University, Summer 2001)

Solution. $\int_C F \cdot dr = \int_{OA} F \cdot dr + \int_{AB} F \cdot dr + \int_{BC} F \cdot dr + \int_{CO} F \cdot dr$
Here

$$r = xi + yj, \quad dr = dxi + dyj, \quad F = x \hat{i} + xy \hat{j}$$

$$F \cdot dr = x^2 dx + xy dy \quad \dots(1)$$

On $OA, y = 0$

$$\therefore F \cdot dr = x^2 dx$$

$$\int_{OA} F \cdot dr = \int_0^a x^2 dx = \left[\frac{x^3}{3} \right]_0^a = \frac{a^3}{3} \quad \dots(2)$$

On $AB, x = a$
(1) becomes

$$\therefore dx = 0$$

$$\therefore F \cdot dr = ay dy$$

$$\int_{Ab} F \cdot dr = \int_0^a ay dy = a \left[\frac{y^2}{2} \right]_0^a = \frac{a^3}{2} \quad \dots(3)$$

On $BC, y = a$
 \Rightarrow (1) becomes

$$\therefore dy = 0$$

$$F \cdot dr = x^2 dx$$

$$\int_{BC} F \cdot dr = \int_a^0 x^2 dx = \left[\frac{x^3}{3} \right]_a^0 = -\frac{a^3}{3} \quad \dots(4)$$

On $CO, x = 0,$
(1) becomes

$$\therefore F \cdot dr = 0$$

$$\int_{CO} F \cdot dr = 0 \quad \dots(5)$$

On adding (2), (3), (4) and (5), we get $\int_C F \cdot dr = \frac{a^3}{3} + \frac{a^3}{2} - \frac{a^3}{3} + 0 = \frac{a^3}{2}$ **Ans.**

Example 67. A vector field is given by

$$F = (2y + 3) \hat{i} + xz \hat{j} + (yz - x) \hat{k}. \text{ Evaluate } \int_C F \cdot dr \text{ along the path } c \text{ is } x = 2t, y = t, z = t^3 \text{ from } t = 0 \text{ to } t = 1. \text{ (Nagpur University, Winter 2003)}$$

Solution. $\int_C F \cdot dr = \int_C (2y + 3) dx + (xz) dy + (yz - x) dz$

$$\left[\text{Since } x = 2t \quad y = t \quad z = t^3 \right]$$

$$\left[\frac{dx}{dt} = 2 \quad \frac{dy}{dt} = 1 \quad \frac{dz}{dt} = 3t^2 \right]$$

Vectors

$$\begin{aligned}
 &= \int_0^1 (2t + 3)(2 dt) + (2t)(t^3) dt + (t^4 - 2t)(3t^2 dt) = \int_0^1 (4t + 6 + 2t^4 + 3t^6 - 6t^3) dt \\
 &= \left[4 \frac{t^2}{2} + 6t + \frac{2}{5} t^5 + \frac{3}{7} t^7 - \frac{6}{4} t^4 \right]_0^1 = \left[2t^2 + 6t + \frac{2}{5} t^5 + \frac{3}{7} t^7 - 3t^4 \right]_0^1 \\
 &= 2 + 6 + \frac{2}{5} + \frac{3}{7} - \frac{3}{2} = 7.32857.
 \end{aligned}$$

Ans.

Example 68. The acceleration of a particle at time t is given by

$$\vec{a} = 18 \cos 3t \hat{i} - 8 \sin 2t \hat{j} + 6t \hat{k}.$$

If the velocity \vec{v} and displacement \vec{r} be zero at $t = 0$, find \vec{v} and \vec{r} at any point t .

Solution. Here, $\vec{a} = \frac{d^2 \vec{r}}{dt^2} = 18 \cos 3t \hat{i} - 8 \sin 2t \hat{j} + 6t \hat{k}$.

On integrating, we have

$$\begin{aligned}
 \vec{v} &= \frac{d\vec{r}}{dt} = \hat{i} \int 18 \cos 3t dt + \hat{j} \int -8 \sin 2t dt + \hat{k} \int 6t dt \\
 \Rightarrow \vec{v} &= 6 \sin 3t \hat{i} + 4 \cos 2t \hat{j} + 3t^2 \hat{k} + \vec{c} \quad \dots(1)
 \end{aligned}$$

At $t = 0$, $\vec{v} = \vec{0}$

Putting $t = 0$ and $\vec{v} = \vec{0}$ in (1), we get

$$\vec{0} = 4 \hat{j} + \vec{c} \Rightarrow \vec{c} = -4 \hat{j}$$

$$\therefore \vec{v} = \frac{d\vec{r}}{dt} = 6 \sin 3t \hat{i} + 4(\cos 2t - 1) \hat{j} + 3t^2 \hat{k}$$

Again integrating, we have

$$\begin{aligned}
 \vec{r} &= \hat{i} \int 6 \sin 3t dt + \hat{j} \int 4(\cos 2t - 1) dt + \hat{k} \int 3t^2 dt \\
 \Rightarrow \vec{r} &= -2 \cos 3t \hat{i} + (2 \sin 2t - 4t) \hat{j} + t^3 \hat{k} + c_1 \quad \dots(2)
 \end{aligned}$$

At, $t = 0$, $\vec{r} = \vec{0}$

Putting $t = 0$ and $\vec{r} = \vec{0}$ in (2), we get

$$\vec{0} = -2 \hat{i} + C_1 \Rightarrow C_1 = 2 \hat{i}$$

$$\text{Hence, } \vec{r} = 2(1 - \cos 3t) \hat{i} + 2(\sin 2t - 2t) \hat{j} + t^3 \hat{k}$$

Ans.

Example 69. If $\vec{A} = (3x^2 + 6y) \hat{i} - 14yz \hat{j} + 20xz^2 \hat{k}$, evaluate the line integral $\int_C \vec{A} \cdot d\vec{r}$ from $(0, 0, 0)$ to $(1, 1, 1)$ along the curve C .

$$x = t, y = t^2, z = t^3. \quad (\text{Uttarakhand, I Semester, Dec. 2006})$$

Solution. We have,

$$\begin{aligned}
 \int_C \vec{A} \cdot d\vec{r} &= \int_C [(3x^2 + 6y) \hat{i} - 14yz \hat{j} + 20xz^2 \hat{k}] \cdot [\hat{i} dx + \hat{j} dy + \hat{k} dz] \\
 &= \int_C [(3x^2 + 6y) dx - 14yz dy + 20xz^2 dz]
 \end{aligned}$$

If $x = t$, $y = t^2$, $z = t^3$, then points $(0, 0, 0)$ and $(1, 1, 1)$ correspond to $t = 0$ and $t = 1$ respectively.

$$\text{Now, } \int_C \vec{A} \cdot d\vec{r} = \int_{t=0}^{t=1} [(3t^2 + 6t^2) dt - 14t^2 \cdot t^3 dt + 20t(t^3)^2 dt]$$

$$= \int_{t=0}^{t=1} [9t^2 dt - 14t^5 \cdot 2t dt + 20t^7 \cdot 3t^2 dt] = \int_0^1 (9t^2 - 28t^6 + 60t^9) dt$$

$$= \left[9 \left(\frac{t^3}{3} \right) - 28 \left(\frac{t^7}{7} \right) + 60 \left(\frac{t^{10}}{10} \right) \right]_0^1 = 3 - 4 + 6 = 5 \quad \text{Ans.}$$

Example 70. Evaluate $\iint_S \vec{A} \cdot \hat{n} \, ds$ where $\vec{A} = (x + y^2)\hat{i} - 2xz\hat{j} + 2yz\hat{k}$ and S is the surface of the plane $2x + y + 2z = 6$ in the first octant. (Nagpur University, Summer 2000)

Solution. A vector normal to the surface "S" is given by
 $\nabla(2x + y + 2z) = \left(\hat{i} \frac{\partial}{\partial x} + \hat{j} \frac{\partial}{\partial y} + \hat{k} \frac{\partial}{\partial z} \right) (2x + y + 2z) = 2\hat{i} + \hat{j} + 2\hat{k}$

And \hat{n} = a unit vector normal to surface S

$$= \frac{2\hat{i} + \hat{j} + 2\hat{k}}{\sqrt{4+1+4}} = \frac{2}{3}\hat{i} + \frac{1}{3}\hat{j} + \frac{2}{3}\hat{k}$$

$$\hat{k} \cdot \hat{n} = \hat{k} \cdot \left(\frac{2}{3}\hat{i} + \frac{1}{3}\hat{j} + \frac{2}{3}\hat{k} \right) = \frac{2}{3}$$

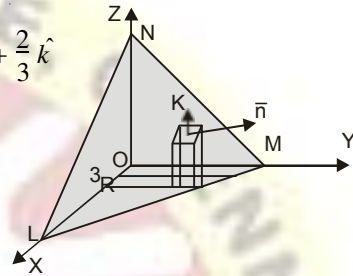

$$\therefore \iint_S \vec{A} \cdot \hat{n} \, ds = \iint_R \frac{\vec{A} \cdot \hat{n}}{\hat{k} \cdot \hat{n}} \, dx \, dy$$

Where R is the projection of S .
 Now, $\vec{A} \cdot \hat{n} = [(x + y^2)\hat{i} - 2xz\hat{j} + 2yz\hat{k}] \cdot \left(\frac{2}{3}\hat{i} + \frac{1}{3}\hat{j} + \frac{2}{3}\hat{k} \right)$

$$= \frac{2}{3}(x + y^2) - \frac{2}{3}xz + \frac{4}{3}yz = \frac{2}{3}y^2 + \frac{4}{3}yz \quad \dots(1)$$

Putting the value of z in (1), we get

$$\vec{A} \cdot \hat{n} = \frac{2}{3}y^2 + \frac{4}{3}y \left(\frac{6 - 2x - y}{2} \right) = \frac{2}{3}y^2 + \frac{2}{3}y(6 - 2x - y)$$

$$= \frac{2}{3}y^2 + \frac{4}{3}y(3 - x) = \frac{4}{3}y(3 - x) \quad \dots(2)$$

Hence, $\iint_S \vec{A} \cdot \hat{n} \, ds = \iint_R \frac{\vec{A} \cdot \hat{n}}{|\hat{k} \cdot \hat{n}|} \, dx \, dy \quad \dots(3)$

Putting the value of $\vec{A} \cdot \hat{n}$ from (2) in (3), we get

$$\iint_S \vec{A} \cdot \hat{n} \, ds = \iint_R \frac{\frac{4}{3}y(3 - x)}{\frac{2}{3}} \, dx \, dy = \int_0^3 \int_0^{6-2x} 2y(3 - x) \, dy \, dx$$

$$= \int_0^3 2(3 - x) \left[\frac{y^2}{2} \right]_0^{6-2x} \, dx$$

$$= \int_0^3 (3 - x)(6 - 2x)^2 \, dx = 4 \int_0^3 (3 - x)^3 \, dx$$

$$= 4 \left[\frac{(3 - x)^4}{4(-1)} \right]_0^3 = - (0 - 81) = 81 \quad \text{Ans.}$$

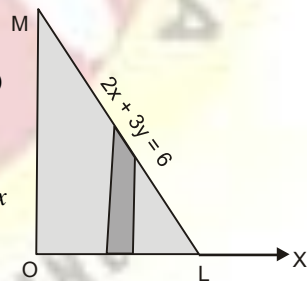

Example 71. Compute $\int_c \vec{F} \cdot d\vec{r}$, where $\vec{F} = \frac{\hat{i}y - \hat{j}x}{x + y}$ and c is the circle $x^2 + y^2 = 1$ traversed counter clockwise.

Vectors

Solution. $\vec{r} = \hat{i}x + \hat{j}y + \hat{k}z, d\vec{r} = \hat{i}dx + \hat{j}dy + \hat{k}dz$

$$\int_c \vec{F} \cdot d\vec{r} = \int_c \frac{\hat{i}y - \hat{j}x}{x^2 + y^2} \cdot (\hat{i}dx + \hat{j}dy + \hat{k}dz)$$

$$= \int_c \frac{ydx - xdy}{x^2 + y^2} = \int_c (ydx - xdy) \quad \dots(1) [x^2 + y^2 = 1]$$

Parametric equation of the circle are $x = \cos \theta, y = \sin \theta$.

Putting $x = \cos \theta, y = \sin \theta, dx = -\sin \theta d\theta, dy = \cos \theta d\theta$ in (1), we get

$$\int_c \vec{F} \cdot d\vec{r} = \int_0^{2\pi} \sin \theta (-\sin \theta d\theta) - \cos \theta (\cos \theta d\theta)$$

$$= -\int_0^{2\pi} (\sin^2 \theta + \cos^2 \theta) d\theta = -\int_0^{2\pi} d\theta = -(\theta)_0^{2\pi} = -2\pi \quad \text{Ans.}$$

Example 72. Show that the vector field $\vec{F} = 2x(y^2 + z^3)\hat{i} + 2x^2y\hat{j} + 3x^2z^2\hat{k}$ is conservative. Find its scalar potential and the work done in moving a particle from $(-1, 2, 1)$ to $(2, 3, 4)$. (A.M.I.E.T.E. June 2010, 2009)

Solution. Here, we have

$$\vec{F} = 2x(y^2 + z^3)\hat{i} + 2x^2y\hat{j} + 3x^2z^2\hat{k}$$

$$\text{Curl } \vec{F} = \nabla \times \vec{F}$$

$$= \begin{vmatrix} \hat{i} & \hat{j} & \hat{k} \\ \frac{\partial}{\partial x} & \frac{\partial}{\partial y} & \frac{\partial}{\partial z} \\ 2x(y^2 + z^3) & 2x^2y & 3x^2z^2 \end{vmatrix} = (0-0)\hat{i} - (6xz^2 - 6xz^2)\hat{j} + (4xy - 4xy)\hat{k} = 0$$

Hence, vector field \vec{F} is irrotational.

To find the scalar potential function ϕ

$$\vec{F} = \nabla\phi$$

$$d\phi = \frac{\partial\phi}{\partial x}dx + \frac{\partial\phi}{\partial y}dy + \frac{\partial\phi}{\partial z}dz = \left(\hat{i}\frac{\partial\phi}{\partial x} + \hat{j}\frac{\partial\phi}{\partial y} + \hat{k}\frac{\partial\phi}{\partial z} \right) \cdot (\hat{i}dx + \hat{j}dy + \hat{k}dz)$$

$$= \left(\hat{i}\frac{\partial}{\partial x} + \hat{j}\frac{\partial}{\partial y} + \hat{k}\frac{\partial}{\partial z} \right) \phi \cdot \left(\hat{i}dx + \hat{j}dy + \hat{k}dz \right) = \nabla\phi \cdot d\vec{r} = \vec{F} \cdot d\vec{r}$$

$$= [2x(y^2 + z^3)\hat{i} + 2x^2y\hat{j} + 3x^2z^2\hat{k}] \cdot (\hat{i}dx + \hat{j}dy + \hat{k}dz)$$

$$= 2x(y^2 + z^3)dx + 2x^2ydy + 3x^2z^2dz$$

$$\phi = \int [2x(y^2 + z^3)dx + 2x^2ydy + 3x^2z^2dz] + C$$

$$\int (2xy^2dx + 2x^2ydy) + (2xz^3dx + 3x^2z^2dz) + C = x^2y^2 + x^2z^3 + C$$

Hence, the scalar potential is $x^2y^2 + x^2z^3 + C$

Now, for conservative field

$$\text{Work done} = \int_{(-1,2,1)}^{(2,3,4)} \vec{F} \cdot d\vec{r} = \int_{(-1,2,1)}^{(2,3,4)} d\phi = [\phi]_{(-1,2,1)}^{(2,3,4)} = [x^2y^2 + x^2z^3 + C]_{(-1,2,1)}^{(2,3,4)}$$

$$= (36 + 256) - (2 - 1) = 291 \quad \text{Ans.}$$

Example 73. A vector field is given by $\vec{F} = (\sin y) \hat{i} + x(1 + \cos y) \hat{j}$. Evaluate the line integral over a circular path $x^2 + y^2 = a^2, z = 0$. (Nagpur University, Winter 2001)

Solution. We have,

$$\begin{aligned} \text{Work done} &= \int_C \vec{F} \cdot d\vec{r} \\ &= \int_C [(\sin y) \hat{i} + x(1 + \cos y) \hat{j}] \cdot [dx \hat{i} + dy \hat{j}] \quad (\because z = 0 \text{ hence } dz = 0) \\ \Rightarrow \int_C \vec{F} \cdot d\vec{r} &= \int_C \sin y \, dx + x(1 + \cos y) \, dy = \int_C (\sin y \, dx + x \cos y \, dy + x \, dy) \\ &= \int_C d(x \sin y) + \int_C x \, dy \end{aligned}$$

(where d is differential operator).

The parametric equations of given path

$$x^2 + y^2 = a^2 \text{ are } x = a \cos \theta, y = a \sin \theta,$$

Where θ varies from 0 to 2π

$$\begin{aligned} \therefore \int_C \vec{F} \cdot d\vec{r} &= \int_0^{2\pi} d[a \cos \theta \sin(a \sin \theta)] + \int_0^{2\pi} a \cos \theta \cdot a \cos \theta \, d\theta \\ &= \int_0^{2\pi} d[a \cos \theta \sin(a \sin \theta)] + \int_0^{2\pi} a^2 \cos^2 \theta \cdot d\theta \\ &= [a \cos \theta \sin(a \sin \theta)]_0^{2\pi} + \int_0^{2\pi} a^2 \cos^2 \theta \, d\theta \\ &= 0 + a^2 \int_0^{2\pi} \left(\frac{1 + \cos 2\theta}{2} \right) d\theta = \frac{a^2}{2} \left[\theta + \frac{\sin 2\theta}{2} \right]_0^{2\pi} \\ &= \frac{a^2}{2} \cdot 2\pi = \pi a^2 \end{aligned}$$

Ans.

Example 74. Determine whether the line integral

$\int (2xy \, z^2) \, dx + (x^2 z^2 + z \cos yz) \, dy + (2x^2 yz + y \cos yz) \, dz$ is independent of the path of integration? If so, then evaluate it from $(1, 0, 1)$ to $\left(0, \frac{\pi}{2}, 1\right)$.

$$\begin{aligned} \text{Solution. } \int_C (2xy \, z^2) \, dx + (x^2 z^2 + z \cos yz) \, dy + (2x^2 yz + y \cos yz) \, dz \\ = \int_C [(2xy \, z^2) \hat{i} + (x^2 z^2 + z \cos yz) \hat{j} + (2x^2 yz + y \cos yz) \hat{k}] \cdot (\hat{i} \, dx + \hat{j} \, dy + \hat{k} \, dz) \\ = \int_C \vec{F} \cdot d\vec{r} \end{aligned}$$

This integral is independent of path of integration if

$$\vec{\nabla} \times \vec{F} = \nabla \phi \Rightarrow \vec{\nabla} \times \vec{F} = 0$$

$$\begin{aligned} \vec{\nabla} \times \vec{F} &= \begin{vmatrix} \hat{i} & \hat{j} & \hat{k} \\ \frac{\partial}{\partial x} & \frac{\partial}{\partial y} & \frac{\partial}{\partial z} \\ 2xy z^2 & x^2 z^2 + z \cos yz & 2x^2 yz + y \cos yz \end{vmatrix} \\ &= (2x^2 z + \cos yz - yz \sin yz - 2x^2 z - \cos yz + yz \sin yz) \hat{i} - (4xyz - 4x yz) \hat{j} + (2xz^2 - 2xz^2) \hat{k} \\ &= 0 \end{aligned}$$

Hence, the line integral is independent of path.

$$d\phi = \frac{\partial \phi}{\partial x} dx + \frac{\partial \phi}{\partial y} dy + \frac{\partial \phi}{\partial z} dz \quad \text{(Total differentiation)}$$

Vectors

$$= \left(\hat{i} \frac{\partial \phi}{\partial x} + \hat{j} \frac{\partial \phi}{\partial y} + \hat{k} \frac{\partial \phi}{\partial z} \right) \cdot (\hat{i} dx + \hat{j} dy + \hat{k} dz) = \nabla \phi \cdot d\vec{r} = \vec{F} \cdot d\vec{r}$$

$$= [(2xyz^2) \hat{i} + (x^2z^2 + z \cos yz) \hat{j} + (2x^2yz + y \cos yz) \hat{k}] \cdot (\hat{i} dx + \hat{j} dy + \hat{k} dz)$$

$$= 2xyz^2 dx + (x^2z^2 + z \cos yz) dy + (2x^2yz + y \cos yz) dz$$

$$= [(2x dx) yz^2 + x^2 (dy) z^2 + x^2 y (2z dz)] + [(\cos yz dy) z + (\cos yz dz) y]$$

$$= d(x^2yz^2) + d(\sin yz)$$

$$\phi = \int d(x^2yz^2) + \int d(\sin yz) = x^2yz^2 + \sin yz$$

$$[\phi]_A^B = \phi(B) - \phi(A)$$

$$= [x^2yz^2 + \sin yz]_{(0, \frac{\pi}{2}, 1)}^{\pi} - [x^2yz^2 + \sin yz]_{(1, 0, 1)} = \left[0 + \sin\left(\frac{\pi}{2} \times 1\right) \right] - [0 + 0]$$

Example 75. Evaluate $\iint_S \vec{A} \cdot \hat{n} dS$, where $\vec{A} = 18xz\hat{i} - 12y\hat{j} + 3yk\hat{k}$ and S is the part of the plane $2x + 3y + 6z = 12$ included in the first octant. (Uttarakhand, I semester, Dec. 2006)

Solution. Here, $A = 18xz\hat{i} - 12y\hat{j} + 3yk\hat{k}$

Given surface $f(x, y, z) = 2x + 3y + 6z - 12 = 0$

$$\text{Normal vector} = \nabla f = \left(\hat{i} \frac{\partial}{\partial x} + \hat{j} \frac{\partial}{\partial y} + \hat{k} \frac{\partial}{\partial z} \right) (2x + 3y + 6z - 12) = 2\hat{i} + 3\hat{j} + 6\hat{k}$$

\hat{n} = unit normal vector at any point (x, y, z) of $2x + 3y + 6z = 12$

$$= \frac{2\hat{i} + 3\hat{j} + 6\hat{k}}{\sqrt{4 + 9 + 36}} = \frac{1}{7}(2\hat{i} + 3\hat{j} + 6\hat{k})$$

$$dS = \frac{dx dy}{\hat{n} \cdot \hat{k}} = \frac{dx dy}{\frac{1}{7}(2\hat{i} + 3\hat{j} + 6\hat{k}) \cdot \hat{k}} = \frac{dx dy}{\frac{6}{7}} = \frac{7}{6} dx dy$$

$$\text{Now, } \iint_S \vec{A} \cdot \hat{n} dS = \iint (18xz\hat{i} - 12y\hat{j} + 3yk\hat{k}) \cdot \frac{1}{7}(2\hat{i} + 3\hat{j} + 6\hat{k}) \frac{7}{6} dx dy$$

$$= \iint (36xz - 36y + 18y) dx dy = \iint (6z - 6 + 3y) dx dy$$

Putting the value of $6z = 12 - 2x - 3y$, we get

$$= \int_0^6 \int_0^{12-2x} (12 - 2x - 3y - 6 + 3y) dx dy$$

$$= \int_0^6 \int_0^{12-2x} (6 - 2x) dx dy$$

$$= \int_0^6 (6 - 2x) dx \int_0^{12-2x} dy$$

$$= \int_0^6 (6 - 2x) dx (y)_0^{12-2x}$$

$$= \int_0^6 (6 - 2x) \frac{1}{3} (12 - 2x) dx = \frac{1}{3} \int_0^6 (4x^2 - 36x + 72) dx$$

$$= \frac{1}{3} \left[\frac{4x^3}{3} - 18x^2 + 72x \right]_0^6 = \frac{1}{3} [4 \times 36 \times 2 - 18 \times 36 + 72 \times 6] = \frac{72}{3} [4 - 9 + 6] = 24 \text{ Ans.}$$

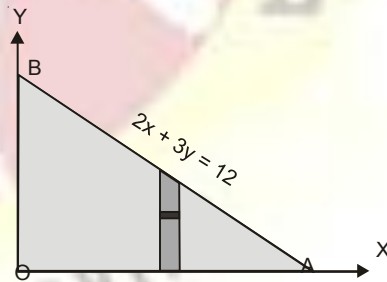

EXERCISE 5.10

- Find the work done by a force $y\hat{i} + x\hat{j}$ which displaces a particle from origin to a point $(\hat{i} + \hat{j})$. **Ans.** 1
- Find the work done when a force $\vec{F} = (x^2 - y^2 + x)\hat{i} - (2xy + y)\hat{j}$ moves a particle from origin to $(1, 1)$ along a parabola $y^2 = x$. **Ans.** $\frac{2}{3}$
- Show that $\vec{V} = (2xy + z^3)\hat{i} + x^2\hat{j} + 3xz^2\hat{k}$ is a conservative field. Find its scalar potential ϕ such that $\vec{V} = \text{grad } \phi$. Find the work done by the force \vec{V} in moving a particle from $(1, -2, 1)$ to $(3, 1, 4)$. **Ans.** $x^2y + xz^3, 202$
- Show that the line integral $\int_c (2xy + 3) dx + (x^2 - 4z) dy - 4y dz$ where c is any path joining $(0, 0, 0)$ to $(1, -1, 3)$ does not depend on the path c and evaluate the line integral. **Ans.** 14
- Find the work done in moving a particle once round the ellipse $\frac{x^2}{25} + \frac{y^2}{16} = 1, z = 0$, under the field of force given by $F = (2x - y + z)\hat{i} + (x + y - z^2)\hat{j} + (3x - 2y + 4z)\hat{k}$. Is the field of force conservative? **Ans.** 40π (A.M.I.E.T.E., Winter 2000)
- $\vec{\nabla}\phi = (y^2 - 2xyz)\hat{i} + (3 + 2xy - xz)\hat{j} + (z^3 - 3x^2yz^2)\hat{k}$, find ϕ . **Ans.** $3y + \frac{y^3}{4} + xy - xyz$
- $\int_C \vec{R} \cdot d\vec{R}$ is independent of the path joining any two point if it is. (A.M.I.E.T.E., June 2010) **Ans.** (i) irrotational field (ii) solenoidal field (iii) rotational field (iv) vector field.

SURFACE INTEGRAL

A surface $r = f(u, v)$ is called smooth if $f(u, v)$ posses continous first order partial derivative.

Let \vec{F} be a vector function and S be the given surface.

Surface integral of a vector function \vec{F} over the surface S is defined as the integral of the components of \vec{F} along the normal to the surface.

Component of \vec{F} along the normal

$= \vec{F} \cdot \hat{n}$, where \hat{n} is the unit normal vector to an element ds and

$$\hat{n} = \frac{\text{grad } f}{|\text{grad } f|} \quad ds = \frac{dx dy}{(\hat{n} \cdot \hat{k})}$$

Surface integral of F over S

$$= \int_S \vec{F} \cdot \hat{n} \quad = \iint_S (F \cdot \hat{n}) ds$$

Note. (1) Flux = $\iint_S (\vec{F} \cdot \hat{n}) ds$ where, \vec{F} represents the velocity of a liquid.

If $\iint_S (\vec{F} \cdot \hat{n}) ds = 0$, then \vec{F} is said to be a solenoidal vector point function.

Example 76. Evaluate $\iint_S (y\hat{i} + x\hat{j} + xy\hat{k}) \cdot \vec{ds}$ where S is the surface of the sphere

$$x^2 + y^2 + z^2 = a^2 \text{ in the first octant. (U.P., I Semester, Dec. 2004)}$$

Solution. Here, $\phi = x^2 + y^2 + z^2 - a^2$

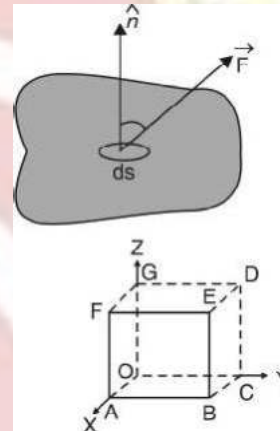

Vectors

$$\begin{aligned} \text{Vector normal to the surface} &= \nabla\phi = \hat{i} \frac{\partial\phi}{\partial x} + \hat{j} \frac{\partial\phi}{\partial y} + \hat{k} \frac{\partial\phi}{\partial z} \\ &= \left(\hat{i} \frac{\partial}{\partial x} + \hat{j} \frac{\partial}{\partial y} + \hat{k} \frac{\partial}{\partial z} \right) (x^2 + y^2 + z^2 - a^2) = 2x\hat{i} + 2y\hat{j} + 2z\hat{k} \\ \hat{n} &= \frac{\nabla\phi}{|\nabla\phi|} = \frac{2x\hat{i} + 2y\hat{j} + 2z\hat{k}}{\sqrt{4x^2 + 4y^2 + 4z^2}} = \frac{x\hat{i} + y\hat{j} + z\hat{k}}{\sqrt{x^2 + y^2 + z^2}} \\ &= \frac{x\hat{i} + y\hat{j} + z\hat{k}}{a} \quad [\because x^2 + y^2 + z^2 = a^2] \end{aligned}$$

Here, $\vec{F} \cdot \hat{n} = (yz\hat{i} + zx\hat{j} + xy\hat{k}) \cdot \frac{x\hat{i} + y\hat{j} + z\hat{k}}{a} = \frac{3xyz}{a}$

Now, $\iint_S \vec{F} \cdot \hat{n} \, ds = \iint_S (F \cdot \hat{n}) \frac{dx \, dy}{|\hat{k} \cdot \hat{n}|} = \int_0^a \int_0^{\sqrt{a^2 - x^2}} \frac{3xyz \, dx \, dy}{a \left(\frac{z}{a} \right)}$
 $= 3 \int_0^a \int_0^{\sqrt{a^2 - x^2}} xy \, dy \, dx = 3 \int_0^a x \left(\frac{y^2}{2} \right)_0^{\sqrt{a^2 - x^2}} dx$
 $= \frac{3}{2} \int_0^a x (a^2 - x^2) \, dx = \frac{3}{2} \left(\frac{a^2 x^2}{2} - \frac{x^4}{4} \right)_0^a = \frac{3}{2} \left(\frac{a^4}{2} - \frac{a^4}{4} \right) = \frac{3a^4}{8}$ **Ans.**

Example 77. Show that $\iint_S \vec{F} \cdot \hat{n} \, ds = \frac{3}{2}$, where $\vec{F} = 4xz\hat{i} - y^2\hat{j} + yz\hat{k}$ and S is the surface of the cube bounded by the planes, $x = 0, x = 1, y = 0, y = 1, z = 0, z = 1$.

Solution. $\iint_S \vec{F} \cdot \hat{n} \, ds = \iint_{OABC} \vec{F} \cdot \hat{n} \, ds + \iint_{DEFG} \vec{F} \cdot \hat{n} \, ds + \iint_{OAGF} \vec{F} \cdot \hat{n} \, ds + \iint_{BCED} \vec{F} \cdot \hat{n} \, ds + \iint_{ABDG} \vec{F} \cdot \hat{n} \, ds + \iint_{OCEF} \vec{F} \cdot \hat{n} \, ds \dots(1)$

S.No.	Surface	Outward normal	ds	
1	OABC	-k	dx dy	z = 0
2	DEFG	k	dx dy	z = 1
3	OAGF	-j	dx dz	y = 0
4	BCED	j	dx dz	y = 1
5	ABDG	i	dy dz	x = 1
6	OCEF	-i	dy dz	x = 0

Now, $\iint_{OABC} \vec{F} \cdot \hat{n} \, ds = \iint_{OABC} (4xz\hat{i} - y^2\hat{j} + yz\hat{k}) \cdot (-\hat{k}) \, dx \, dy = \int_0^1 \int_0^1 -yz \, dx \, dy = 0$ (as $z = 0$)
 $\iint_{DEFG} (4xz\hat{i} - y^2\hat{j} + yz\hat{k}) \cdot \hat{k} \, dx \, dy = \iint_{DEFG} yz \, dx \, dy = \int_0^1 \int_0^1 y(1) \, dx \, dy = \int_0^1 \left[\frac{y^2}{2} \right]_0^1 = \frac{1}{2} = \frac{1}{2}$
 $\iint_{OAGF} (4xz\hat{i} - y^2\hat{j} + yz\hat{k}) \cdot (-\hat{j}) \, dx \, dz = \iint_{OAGF} y^2 \, dx \, dz = 0$ (as $y = 0$)

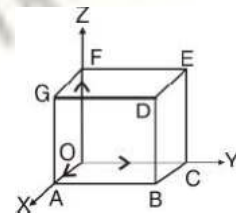

Vectors

$$\iint_{BCED} (4xz\hat{i} - y^2\hat{j} + yz\hat{k}) \cdot \hat{j} \, dx \, dz = \iint_{BCED} (-y^2) \, dx \, dz$$

$$= - \int_0^1 dx \int_0^1 dz = - (x)_0^1 (z)_0^1 = -1 \quad (\text{as } y = 1)$$

$$\iint_{ABDG} (4xz\hat{i} - y^2\hat{j} + yz\hat{k}) \cdot \hat{i} \, dy \, dz = \iint_{ABDG} 4xz \, dy \, dz = \int_0^1 \int_0^1 4(1)z \, dy \, dz$$

$$= 4(y)_0^1 \left(\frac{z^2}{2} \right)_0^1 = 4(1) \left(\frac{1}{2} \right) = 2$$

$$\iint_{OCEF} (4xz\hat{i} - y^2\hat{j} + yz\hat{k}) \cdot (-\hat{i}) \, dy \, dz = \int_0^1 \int_0^1 -4xz \, dy \, dz = 0 \quad (\text{as } x = 0)$$

On putting these values in (1), we get

$$\iint_S \vec{F} \cdot \vec{n} \, ds = 0 + \frac{1}{2} + 0 - 1 + 2 + 0 = \frac{3}{2} \quad \text{Proved.}$$

EXERCISE 5.11

1. Evaluate $\iint_S \vec{A} \cdot \vec{n} \, ds$, where $\vec{A} = (x + y)\hat{i} - 2x\hat{j} + 2yz\hat{k}$ and S is the surface of the plane $2x + y + 2z = 6$ in the first octant. **Ans. 81**

2. Evaluate $\iint_S \vec{A} \cdot \vec{n} \, ds$, where $\vec{A} = z\hat{i} + x\hat{j} - 3y^2z\hat{k}$ and S is the surface of the cylinder $x^2 + y^2 = 16$ included in the first octant between $z = 0$ and $z = 5$. **Ans. 90**

3. If $\vec{r} = t^2\hat{i} - t^2\hat{j} + (t-1)\hat{k}$ and $S = 2t\hat{i} + 6t\hat{k}$, evaluate $\int_0^2 \vec{r} \cdot \vec{S} \, dt$. **Ans. 12**

4. Evaluate $\iint_S \vec{F} \cdot \vec{n} \, dS$, where, $\vec{F} = 18z\hat{i} - 12\hat{j} + 3y\hat{k}$ and S is the surface of the plane $2x + 3y + 6z = 12$ in the first octant. **Ans. 24**

5. Evaluate $\iint_S \vec{F} \cdot \vec{n} \, ds$, where, $F = 2yx\hat{i} - yz\hat{j} + x^2\hat{k}$ over the surface S of the cube bounded by the coordinate planes and planes $x = a$, $y = a$ and $z = a$. **Ans. $\frac{1}{2}a^4$**

6. If $\vec{F} = 2y\hat{i} - 3\hat{j} + x^2\hat{k}$ and S is the surface of the parabolic cylinder $y^2 = 8x$ in the first octant bounded by the planes $y = 4$, and $z = 6$, then evaluate $\iint_S \vec{F} \cdot \vec{n} \, dS$. **Ans. 132**

VOLUME INTEGRAL

Let \vec{F} be a vector point function and volume V enclosed by a closed surface.

The volume integral = $\iiint_V \vec{F} \, dv$

Example 78. If $\vec{F} = 2z\hat{i} - x\hat{j} + y\hat{k}$, evaluate $\iiint_V \vec{F} \, dv$ where, v is the region bounded by the surfaces

$$x = 0, y = 0, x = 2, y = 4, z = x^2, z = 2.$$

Solution. $\iiint_V \vec{F} \, dv = \iiint_V (2z\hat{i} - x\hat{j} + y\hat{k}) \, dx \, dy \, dz$

$$= \int_0^2 dx \int_0^4 dy \int_{x^2}^2 (2z\hat{i} - x\hat{j} + y\hat{k}) \, dz = \int_0^2 dx \int_0^4 dy [z^2\hat{i} - xz\hat{j} + yzk\hat{k}]_{x^2}^2$$

$$= \int_0^2 dx \int_0^4 dy [4\hat{i} - 2x\hat{j} + 2yk\hat{k} - x^4\hat{i} + x^3\hat{j} - x^2yk\hat{k}]$$

Vectors

$$\begin{aligned}
 &= \int_0^2 dx \left[4y\hat{i} - 2xy\hat{j} + y^2\hat{k} - x^4y\hat{i} + x^3y\hat{j} - \frac{x^2y^2}{2}\hat{k} \right]_0^4 \\
 &= \int_0^2 (16\hat{i} - 8x\hat{j} + 16\hat{k} - 4x^4\hat{i} + 4x^3\hat{j} - 8x^2\hat{k}) dx \\
 &= \left[16x\hat{i} - 4x^2\hat{j} + 16x\hat{k} - \frac{4x^5}{5}\hat{i} + x^4\hat{j} - \frac{8x^3}{3}\hat{k} \right]_0^2 \\
 &= 32\hat{i} - 16\hat{j} + 32\hat{k} - \frac{128}{5}\hat{i} + 16\hat{j} - \frac{64}{3}\hat{k} = \frac{32\hat{i}}{5} + \frac{32\hat{k}}{3} = \frac{32}{15}(3\hat{i} + 5\hat{k}) \quad \text{Ans.}
 \end{aligned}$$

EXERCISE 5.12

- If $\vec{F} = (2x^2 - 3z)\hat{i} - 2xy\hat{j} - 4x\hat{k}$, then evaluate $\iiint_V \nabla \cdot \vec{F} dV$, where V is bounded by the plane $x = 0, y = 0, z = 0$ and $2x + 2y + z = 4$. Ans. $\frac{8}{3}$
- Evaluate $\iiint_V \phi dV$, where $\phi = 45x^2y$ and V is the closed region bounded by the planes $4x + 2y + z = 8, x = 0, y = 0, z = 0$. Ans. 128
- If $\vec{F} = (2x^2 - 3z)\hat{i} - 2xy\hat{j} - 4x\hat{k}$, then evaluate $\iiint_V \nabla \times \vec{F} dV$, where V is the closed region bounded by the planes $x = 0, y = 0, z = 0$ and $2x + 2y + z = 4$. Ans. $\frac{8}{3}(\hat{j} - \hat{k})$
- Evaluate $\iiint_V (2x + y) dV$, where V is closed region bounded by the cylinder $z = 4 - x^2$ and the planes $x = 0, y = 0, y = 2$ and $z = 0$. Ans. $\frac{80}{3}$
- If $\vec{F} = 2xz\hat{i} - x\hat{j} + y^2\hat{k}$, evaluate $\iiint_V \vec{F} dV$ over the region bounded by the surfaces $x = 0, y = 0, y = 6$ and $z = x^2, z = 4$. Ans. $(16\hat{i} - 3\hat{j} + 48\hat{k})$

GREEN'S THEOREM (For a plane)

Statement. If $\phi(x, y), \psi(x, y), \frac{\partial \phi}{\partial y}$ and $\frac{\partial \psi}{\partial x}$ be continuous functions over a region R bounded

by simple closed curve C in $x - y$ plane, then

$$\int_C (\phi dx + \psi dy) = \iint_R \left(\frac{\partial \psi}{\partial x} - \frac{\partial \phi}{\partial y} \right) dx dy \quad (\text{AMIETE, June 2010, U.P., I Semester, Dec. 2007})$$

Proof. Let the curve C be divided into two curves C_1 (ABC) and C_2 (CDA).

Let the equation of the curve C_1 (ABC) be $y = y_1(x)$ and equation of the curve C_2 (CDA) be $y = y_2(x)$.

Let us see the value of

$$\begin{aligned}
 \iint_R \frac{\partial \phi}{\partial y} dx dy &= \int_{x=a}^{x=c} \left[\int_{y=y_1(x)}^{y=y_2(x)} \frac{\partial \phi}{\partial y} dy \right] dx = \int_a^c [\phi(x, y)]_{y=y_1(x)}^{y=y_2(x)} dx \\
 &= \int_a^c [\phi(x, y_2) - \phi(x, y_1)] dx = \int_a^c \phi(x, y_2) dx - \int_a^c \phi(x, y_1) dx \\
 &= \int_a^c \phi(x, y_2) dx + \int_c^a \phi(x, y_1) dx \\
 &= - \left[\int_{c_2} \phi(x, y) dx + \int_{c_1} \phi(x, y) dx \right] = - \int_C \phi(x, y) dx
 \end{aligned}$$

Thus,
$$\int_c \phi dx = - \iint_R \frac{\partial \phi}{\partial y} dx dy \quad \dots(1)$$

Similarly, it can be shown that

$$\int_c \psi dy = \iint_R \frac{\partial \psi}{\partial x} dx dy \quad \dots(2)$$

On adding (1) and (2), we get
$$\int_c (\phi dx + \psi dy) = \iint_R \left(\frac{\partial \psi}{\partial x} - \frac{\partial \phi}{\partial y} \right) dx dy \quad \text{Proved.}$$

Note. Green's Theorem in vector form

where,
$$\int_c \vec{F} \cdot d\vec{r} = \iint_R (\nabla \times \vec{F}) \cdot \hat{k} dR$$
 is a unit vector along z-axis and $dR = dx dy$.

$$\vec{F} = \phi \hat{i} + \psi \hat{j}, \vec{r} = x \hat{i} + y \hat{j}, \hat{k}$$

Example 79. A vector field \vec{F} is given by $\vec{F} = \sin yi + x(1 + \cos y)j$.

Evaluate the line integral $\int_C \vec{F} \cdot d\vec{r}$ where C is the circular path given by $x^2 + y^2 = a^2$.

Solution.

$$\vec{F} = \sin yi + x(1 + \cos y)j$$

$$\int_C \vec{F} \cdot d\vec{r} = \int_C [\sin yi + x(1 + \cos y)j] \cdot (\hat{i}dx + \hat{j}dy) = \int_C \sin y dx + x(1 + \cos y) dy$$

On applying Green's Theorem, we have

$$\int_c (\phi dx + \psi dy) = \iint_s \left(\frac{\partial \psi}{\partial x} - \frac{\partial \phi}{\partial y} \right) dx dy$$

$$= \iint_s [(1 + \cos y) - \cos y] dx dy$$

where s is the circular plane surface of radius a .

$$= \iint_s dx dy = \text{Area of circle} = \pi a^2. \quad \text{Ans.}$$

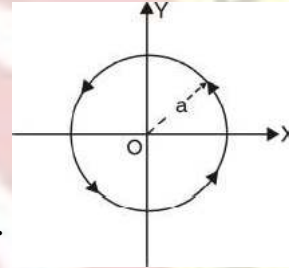

Example 80. Using Green's Theorem, evaluate $\int_c (x^2 y dx + x^2 dy)$, where c is the boundary described counter clockwise of the triangle with vertices $(0, 0), (1, 0), (1, 1)$.

(U.P., I Semester, Winter 2003)

Solution. By Green's Theorem, we have

$$\int_c (\phi dx + \psi dy) = \iint_R \left(\frac{\partial \psi}{\partial x} - \frac{\partial \phi}{\partial y} \right) dx dy$$

$$= \int_0^1 \int_0^x (x^2 y dx + x^2 dy) = \int_0^1 \int_0^x (2x - x^2) dx dy$$

$$= \int_0^1 (2x - x^2) dx [y]^0^x = \int_0^1 (2x - x^2)(x) dx = \int_0^1 (2x^2 - x^3) dx$$

$$= \left(\frac{2}{3}x^3 - \frac{1}{4}x^4 \right) \Big|_0^1 = \frac{5}{12}$$

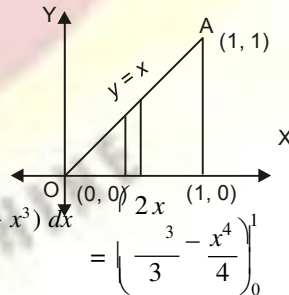

Ans.

Example 81. State and verify Green's Theorem in the plane for $\int (3x^2 - 8y^2) dx + (4y - 6xy) dy$ where C is the boundary of the region bounded by $x \geq 0, y \leq 0$ and $2x - 3y = 6$.

(Uttarakhand, I Semester, Dec. 2006)

Vectors

Solution. Statement: See Article 24.4 on page 576.

Here the closed curve C consists of straight lines OB , BA and AO , where coordinates of A and B are $(3, 0)$ and $(0, -2)$ respectively. Let R be the region bounded by C .

Then by Green's Theorem in plane, we have

$$\begin{aligned} & \int [(3x^2 - 8y^2) dx + (4y - 6xy) dy] \\ &= \iint_R \left[\frac{\partial}{\partial x} (4y - 6xy) - \frac{\partial}{\partial y} (3x^2 - 8y^2) \right] dx dy \quad \dots(1) \\ &= \iint_R (-6y + 16y) dx dy = \iint_R 10y dx dy \\ &= 10 \int_0^3 dx \int_{\frac{1}{3}(2x-6)}^0 y dy = 10 \int_0^3 dx \left[\frac{y^2}{2} \right]_{\frac{1}{3}(2x-6)}^0 = -\frac{5}{9} \int_0^3 dx (2x-6)^2 \\ &= -\frac{5}{9} \left[\frac{(2x-6)^3}{3 \times 2} \right]_0^3 = -\frac{5}{54} (0+6)^3 = -\frac{5}{54} (216) = -20 \quad \dots(2) \end{aligned}$$

Now we evaluate L.H.S. of (1) along OB , BA and AO .

Along OB , $x = 0$, $dx = 0$ and y varies from 0 to -2 .

Along BA , $x = \frac{1}{2}(6+3y)$, $dx = \frac{3}{2} dy$ and y varies from -2 to 0.

and along AO , $y = 0$, $dy = 0$ and x varies from 3 to 0.

$$\begin{aligned} \text{L.H.S. of (1)} &= \int [(3x^2 - 8y^2) dx + (4y - 6xy) dy] \\ &= \int_{OB} [(3x^2 - 8y^2) dx + (4y - 6xy) dy] + \int_{BA} [(3x^2 - 8y^2) dx + (4y - 6xy) dy] \\ &\quad + \int_{AO} [(3x^2 - 8y^2) dx + (4y - 6xy) dy] \\ &= \int_0^{-2} 4y dy + \int_{-2}^0 \left[\frac{3}{4} (6+3y)^2 - 8y^2 \right] \left(\frac{3}{2} dy \right) + [4y - 3(6+3y)y] dy + \int_3^0 3x^2 dx \\ &= [2y^2]_{-2}^0 + \int_{-2}^0 \left[\frac{9}{4} (6+3y)^2 - 12y^2 + 4y - 18y - 9y^2 \right] dy + (x^3)^0 \\ &= 2[4] + \int_{-2}^0 \left[\frac{9}{4} (6+3y)^2 - 21y^2 - 14y \right] dy + (0-27) \\ &= 8 + \left[\frac{9}{8} (6+3y)^3 - 7y^3 - 7y^2 \right]_{-2}^0 - 27 = -19 + \left[\frac{216}{8} + 7(-2)^3 + 7(-2)^2 \right] \\ &= -19 + 27 - 56 + 28 = -20 \quad \dots(3) \end{aligned}$$

With the help of (2) and (3), we find that (1) is true and so Green's Theorem is verified.

Example 82. Apply Green's Theorem to evaluate $\int_C [(2x^2 - y^2) dx + (x^2 + y^2) dy]$, where C is the boundary of the area enclosed by the x -axis and the upper half of circle $x^2 + y^2 = a^2$.
(M.D.U. Dec. 2009, U.P., I Sem., Dec. 2004)

Solution. $\int_C [(2x^2 - y^2) dx + (x^2 + y^2) dy]$

By Green's Theorem, we've $\int_C (\phi dx + \psi dy) = \iint_S \left(\frac{\partial \psi}{\partial x} - \frac{\partial \phi}{\partial y} \right) dx dy$

Vectors

$$\begin{aligned}
 &= \int_{-a}^a \int_0^{\sqrt{a^2-x^2}} \left[\frac{\partial}{\partial x} (x^2 + y^2) - \frac{\partial}{\partial y} (2x^2 - y) \right] dx dy \\
 &= \int_{-a}^a \int_0^{\sqrt{a^2-x^2}} (2x + 2y) dx dy = 2 \int_{-a}^a dx \int_0^{\sqrt{a^2-x^2}} (x + y) dy \\
 &= 2 \int_{-a}^a dx \left[xy + \frac{y^2}{2} \right]_0^{\sqrt{a^2-x^2}} = 2 \int_{-a}^a \left(x\sqrt{a^2-x^2} + \frac{a^2-x^2}{2} \right) dx \\
 &= 2 \int_{-a}^a x\sqrt{a^2-x^2} dx + \int_{-a}^a (a^2-x) dx = 0, \quad \left[\int_{-a}^a f(x) dx = 2 \int_0^a f(x) dx, f \text{ is even} \right. \\
 &\quad \left. = 0, f \text{ is odd} \right]
 \end{aligned}$$

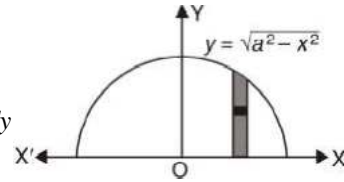

$$= 0 + 2 \int_0^a (a^2 - x^2) dx = 2 \left[a^2x - \frac{x^3}{3} \right]_0^a = 2 \left(a^3 - \frac{a^3}{3} \right) = \frac{4a^3}{3} \quad \text{Ans.}$$

Example 83. Evaluate $\int_C \frac{-y}{x^2 + y^2} dx + \frac{x}{x^2 + y^2} dy$, where $C = C_1 \cup C_2$ with $C_1 : x^2 + y^2 = 1$ and $C_2 : x = \pm 2, y = \pm 2$. (Gujarat, I Semester, Jan 2009)

$$\begin{aligned}
 \text{Solution. } &\int_C \frac{-y}{x^2 + y^2} dx + \frac{x}{x^2 + y^2} dy \\
 &= \iint \left(\frac{\partial}{\partial x} \frac{x}{x^2 + y^2} + \frac{\partial}{\partial y} \frac{-y}{x^2 + y^2} \right) dx dy \\
 &= \iint \left[\frac{(x^2 + y^2) - 2x(x)}{(x^2 + y^2)^2} + \frac{(x^2 + y^2) - 2y(y)}{(x^2 + y^2)^2} \right] dx dy \\
 &= \iint \left[\frac{x^2 + y^2 - 2x^2}{(x^2 + y^2)^2} + \frac{x^2 + y^2 - 2y^2}{(x^2 + y^2)^2} \right] dx dy \\
 &= \iint \left[\frac{y^2 - x^2}{(x^2 + y^2)^2} + \frac{x^2 - y^2}{(x^2 + y^2)^2} \right] dx dy = \iint 0 dx dy = 0 \quad \text{Ans.}
 \end{aligned}$$

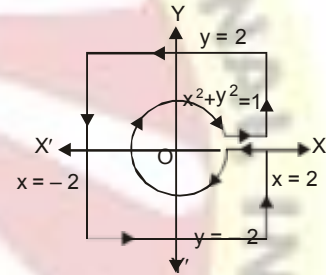

AREA OF THE PLANE REGION BY GREEN'S THEOREM

Proof. We know that

$$\int_C Mdx + Ndy = \iint_A \left(\frac{\partial N}{\partial x} - \frac{\partial M}{\partial y} \right) dx dy \quad \dots(1)$$

On putting $N = x \left(\frac{\partial N}{\partial x} = 1 \right)$ and $M = -y \left(\frac{\partial M}{\partial y} = 1 \right)$ in (1), we get

$$\int_C -y dx + x dy = \iint_A [1 - (-1)] dx dy = 2 \iint dx dy = 2A$$

$$\text{Area} = \frac{1}{2} \int_C (x dy - y dx)$$

Example 84. Using Green's theorem, find the area of the region in the first quadrant bounded by the curves

$$y = x, y = \frac{1}{x}, y = \frac{x}{4} \quad \text{(U.P. I, Semester, Dec. 2008)}$$

Solution. By Green's Theorem Area A of the region bounded by a closed curve C is given by

Vectors

$$A = \frac{1}{2} \int_C (x dy - y dx)$$

Here, C consists of the curves $C_1 : y = \frac{x}{4}$, $C_2 : y = \frac{1}{x}$

$$\left[A = \frac{1}{2} \int_C (x dy - y dx) = \frac{1}{2} \left(\int_{C_1} + \int_{C_2} + \int_{C_3} \right) (x dy - y dx) \right]$$

$$\left[\frac{1}{2} \int_C (x dy - y dx) = \frac{1}{2} \left(\int_{C_1} + \int_{C_2} + \int_{C_3} \right) (x dy - y dx) \right]$$

Along $C_1 : y = \frac{x}{4}, dy = \frac{1}{4} dx, x: 0 \text{ to } 2$

$$I_1 = \int_{C_1} (x dy - y dx) = \int_0^2 \left(x \frac{1}{4} dx - \frac{x}{4} dx \right) = 0$$

Along $C_2 : y = \frac{1}{x}, dy = -\frac{1}{x^2} dx, x: 2 \text{ to } 1$

$$I_2 = \int_{C_2} (x dy - y dx) = \int_2^1 \left(x \left(-\frac{1}{x^2} \right) dx - \frac{1}{x} dx \right) = [-2 \log x]_2^1 = 2 \log 2$$

Along $C_3 : y = x, dy = dx; x: 1 \text{ to } 0$

$$I_3 = \int_{C_3} (x dy - y dx) = \int_1^0 (x dx - x dx) = 0$$

$$A = \frac{1}{2} (I_1 + I_2 + I_3) = \frac{1}{2} (0 + 2 \log 2 + 0) = \log 2$$

Ans.

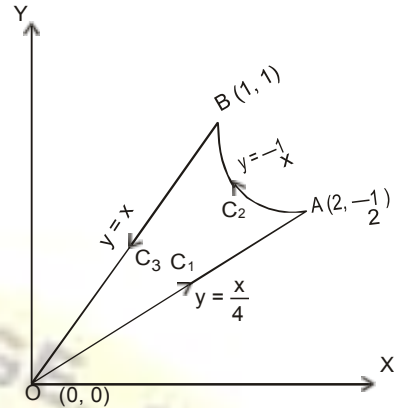

EXERCISE 5.13

- Evaluate $\int_C [(3x^2 - 6yz) dx + (2y + 3xz) dy + (1 - 4xyz^2) dz]$ from $(0, 0, 0)$ to $(1, 1, 1)$ along the path c given by the straight line from $(0, 0, 0)$ to $(0, 0, 1)$ then to $(0, 1, 1)$ and then to $(1, 1, 1)$.
- Verify Green's Theorem in plane for $\int_C (x^2 + 2xy) dx + (y^2 + x^3y) dy$, where c is a square with the vertices $P(0, 0), Q(1, 0), R(1, 1)$ and $S(0, 1)$. Ans. $-\frac{1}{2}$
- Verify Green's Theorem for $\int_C (x^2 - 2xy) dx + (x^2y + 3) dy$ around the boundary c of the region $y^2 = 8x$ and $x = 2$.
- Use Green's Theorem in a plane to evaluate the integral $\int_C [(2x^2 - y^2) dx + (x^2 + y^2) dy]$, where c is the boundary in the xy -plane of the area enclosed by the x -axis and the semi-circle $x^2 + y^2 = 1$ in the upper half xy -plane. Ans. $\frac{4}{3}$
- Apply Green's Theorem to evaluate $\int_C [(y - \sin x) dy + \cos x dx]$, where c is the plane triangle enclosed by the lines $y = 0, x = \frac{\pi}{2}$ and $y = \frac{2x}{\pi}$. Ans. $-\frac{\pi^2 + 8}{4\pi}$
- Either directly or by Green's Theorem, evaluate the line integral $\int_C e^{-x} (\cos y dx - \sin y dy)$, where c is the rectangle with vertices $(0, 0), (\pi, 0), \left(\pi, \frac{\pi}{2}\right)$ and $\left(0, \frac{\pi}{2}\right)$. Ans. $2(1 - e^{-\pi})$
(AMIETE II Sem June 2010)
- Verify the Green's Theorem to evaluate the line integral $\int_C (2y^2 dx + 3x dy)$, where c is the boundary of the closed region bounded by $y = x$ and $y = x^2$.

(U.P., I Semester, Dec. 20005, AMIETE Summer 2004, Winter 2001) Ans. $\frac{27}{4}$

Vectors

8. Evaluate $\iint_S \vec{F} \cdot \hat{n} ds$, where $\vec{F} = xy \hat{i} - x^2 \hat{j} + (x+z) \hat{k}$ and s is the region of the plane $2x + 2y + z = 6$ in the first octant. (A.M.I.E.T.E., Summer 2004, Winter 2001) Ans. $\frac{27}{4}$
9. Verify Green's Theorem for $\int_C [(xy + y^2) dx + x^2 dy]$ where C is the boundary by $y = x$ and $y = x^2$. (AMIETE, June 2010)

STOKE'S THEOREM (Relation between Line Integral and Surface Integral)

(Uttarakhand, I Sem. 2008, U.P., Ist Semester, Dec. 2006)

Statement. Surface integral of the component of curl \vec{F} along the normal to the surface S , taken over the surface S bounded by curve C is equal to the line integral of the vector point function \vec{F} taken along the closed curve C .

Mathematically

$$\int_C \vec{F} \cdot d\vec{r} = \iint_S \text{curl } \vec{F} \cdot \hat{n} ds$$

where $\hat{n} = \cos \alpha \hat{i} + \cos \beta \hat{j} + \cos \gamma \hat{k}$ is a unit external normal to any surface ds ,

Proof. Let $\vec{r} = x\hat{i} + y\hat{j} + z\hat{k}$
 $d\vec{r} = \hat{i} dx + \hat{j} dy + \hat{k} dz$
 $F = F_1 \hat{i} + F_2 \hat{j} + F_3 \hat{k}$

On putting the values of $\vec{F}, d\vec{r}$ in the statement of the theorem

$$\begin{aligned} & \int_C (F_1 \hat{i} + F_2 \hat{j} + F_3 \hat{k}) \cdot (\hat{i} dx + \hat{j} dy + \hat{k} dz) \\ &= \iint_S \left[\hat{i} \frac{\partial}{\partial x} + \hat{j} \frac{\partial}{\partial y} + \hat{k} \frac{\partial}{\partial z} \right] \times (F_1 \hat{i} + F_2 \hat{j} + F_3 \hat{k}) \cdot (\cos \alpha \hat{i} + \cos \beta \hat{j} + \cos \gamma \hat{k}) ds \\ & \int (F_1 dx + F_2 dy + F_3 dz) = \iint_S \left[\left(\frac{\partial F_3}{\partial y} - \frac{\partial F_2}{\partial z} \right) \hat{i} + \left(\frac{\partial F_1}{\partial z} - \frac{\partial F_3}{\partial x} \right) \hat{j} + \left(\frac{\partial F_2}{\partial x} - \frac{\partial F_1}{\partial y} \right) \hat{k} \right] \cdot (\cos \alpha \hat{i} + \cos \beta \hat{j} + \cos \gamma \hat{k}) ds \\ &= \iint_S \left[\left(\frac{\partial F_3}{\partial y} - \frac{\partial F_2}{\partial z} \right) \cos \alpha + \left(\frac{\partial F_1}{\partial z} - \frac{\partial F_3}{\partial x} \right) \cos \beta + \left(\frac{\partial F_2}{\partial x} - \frac{\partial F_1}{\partial y} \right) \cos \gamma \right] ds \quad \dots(1) \end{aligned}$$

Let us first prove

$$\int_C F_1 dx = \iint_S \left[\left(\frac{\partial F_1}{\partial z} \cos \beta - \frac{\partial F_1}{\partial y} \cos \gamma \right) \right] ds \quad \dots(2)$$

Let the equation of the surface S be $z = g(x, y)$. The projection of the surface on $x - y$ plane is region R .

$$\begin{aligned} \int_C F_1(x, y, z) dx &= \int_C F_1[x, y, g(x, y)] dx \\ &= - \iint_R \frac{\partial}{\partial y} F_1(x, y, g) dx dy \quad \text{[By Green's Theorem]} \\ &= - \iint_R \left(\frac{\partial F_1}{\partial y} + \frac{\partial F_1}{\partial z} \frac{\partial g}{\partial y} \right) dx dy \quad \dots(3) \end{aligned}$$

The direction cosines of the normal to the surface $z = g(x, y)$ are given by

$$\frac{\cos \alpha}{-\frac{\partial g}{\partial x}} = \frac{\cos \beta}{-\frac{\partial g}{\partial y}} = \frac{\cos \gamma}{1}$$

Vectors

And $dx dy =$ projection of ds on the xy -plane $= ds \cos \gamma$

Putting the values of ds in R.H.S. of (2)

$$\begin{aligned} \iint_S \left(\frac{\partial F_1}{\partial z} \cos \beta - \frac{\partial F_1}{\partial y} \cos \gamma \right) ds &= \iint_R \left(\frac{\partial F_1}{\partial z} \cos \beta - \frac{\partial F_1}{\partial y} \cos \gamma \right) \frac{dx dy}{\cos \gamma} \\ &= \iint_R \left(\frac{\partial F_1 \cos \beta}{\partial z \cos \gamma} - \frac{\partial F_1}{\partial y} \right) dx dy = \iint_R \left(\frac{\partial F_1}{\partial z} \left(-\frac{\partial g}{\partial y} \right) - \frac{\partial F_1}{\partial y} \right) dx dy \\ &= - \iint_R \left(\frac{\partial F_1}{\partial y} + \frac{\partial F_1}{\partial z} \frac{\partial g}{\partial y} \right) dx dy \end{aligned} \quad \dots(4)$$

From (3) and (4), we get

$$\int_c F_1 dx = \iint_S \left(\frac{\partial F_1}{\partial z} \cos \beta - \frac{\partial F_1}{\partial y} \cos \gamma \right) ds \quad \dots(5)$$

Similarly, $\int_c F_2 dy = \iint_S \left(\frac{\partial F_2}{\partial x} \cos \gamma - \frac{\partial F_2}{\partial z} \cos \alpha \right) ds \quad \dots(6)$

and $\int_c F_3 dz = \iint_S \left(\frac{\partial F_3}{\partial y} \cos \alpha - \frac{\partial F_3}{\partial x} \cos \beta \right) ds \quad \dots(7)$

On adding (5), (6) and (7), we get

$$\int_c (F_1 dx + F_2 dy + F_3 dz) = \iint_S \left(\frac{\partial F_1}{\partial z} \cos \beta - \frac{\partial F_1}{\partial y} \cos \gamma + \frac{\partial F_2}{\partial x} \cos \gamma - \frac{\partial F_2}{\partial z} \cos \alpha + \frac{\partial F_3}{\partial y} \cos \alpha - \frac{\partial F_3}{\partial x} \cos \beta \right) ds$$

Proved.

ANOTHER METHOD OF PROVING STOKES'S THEOREM

The circulation of vector F around a closed curve C is equal to the flux of the curl of the vector through the surface S bounded by the curve C .

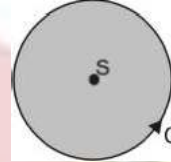

$$\int_c \vec{E} \cdot d\vec{r} = \iint_S \text{curl } \vec{F} \cdot \vec{n} dS = \iint_S \text{curl } \vec{F} \cdot d\vec{S}$$

Proof : The projection of any curved surface over xy -plane can be treated as kernel of the surface integral over actual surface.

Now, $\iint_S (\nabla \times \vec{F}) \cdot \vec{k} dS = \iint_S (\nabla \times \vec{F}) \cdot (\hat{i} \times \hat{j}) dx dy \quad [k = \hat{i} \times \hat{j}]$

$$= \iint_S [(F_x \hat{j} - F_y \hat{i}) \cdot (\hat{i} \times \hat{j})] dx dy = \iint_S [F_x - F_y] dx dy$$

$$= \iint_S [F_x dx + F_y dy] \text{ [By Green's theorem]}$$

$$= \iint_S [\hat{i} F_x + \hat{j} F_y] \cdot (\hat{i} dx + \hat{j} dy) = \int_c \vec{F} \cdot d\vec{r}$$

$$\iint_S \text{curl } \vec{F} \cdot \vec{n} dS = \int_c \vec{F} \cdot d\vec{r}$$

where, $\vec{F} = F_x \hat{i} + F_y \hat{j} + F_z \hat{k}$ and $d\vec{r} = dx \hat{i} + dy \hat{j} + dz \hat{k}$

Example 85. Evaluate by Stokes theorem $\int_c (yz dx + zx dy + xy dz)$ where C is the curve $x^2 + y^2 = 1, z = y^2$. (M.D.U., Dec 2009)

Solution. Here we have $\int_c yz dx + zx dy + xy dz$

$$= \int_c (yz \hat{i} + zx \hat{j} + xy \hat{k}) \cdot (\hat{i} dx + \hat{j} dy + \hat{k} dz)$$

Vectors

$$= \int F \cdot dx$$

$$\text{Curl } \vec{F} = \begin{vmatrix} \hat{i} & \hat{j} & \hat{k} \\ \frac{\partial}{\partial x} & \frac{\partial}{\partial y} & \frac{\partial}{\partial z} \\ yz & zx & xy \end{vmatrix}$$

$$= \int \text{curl } F \cdot \hat{n} \, ds$$

$$= (x-x)\hat{i} + (y-y)\hat{j} + (z-z)\hat{k}$$

$$= 0 = 0$$

Ans.

Example 86. Using Stoke's theorem or otherwise, evaluate

$$\int_c [(2x - y) dx - yz^2 dy - y^2 z dz]$$

where c is the circle $x^2 + y^2 = 1$, corresponding to the surface of sphere of unit radius.

(U.P., I Semester, Winter 2001)

Solution. $\int_c [(2x - y) dx - yz^2 dy - y^2 z dz]$

$$= \int_c [(2x - y)\hat{i} - yz^2\hat{j} - y^2z\hat{k}] \cdot (\hat{i} dx + \hat{j} dy + \hat{k} dz)$$

By Stoke's theorem $\int_c \vec{F} \cdot d\vec{r} = \iint_s \text{Curl } \vec{F} \cdot \vec{n} \, ds$... (1)

$$\text{Curl } \vec{F} = \nabla \times \vec{F} = \begin{vmatrix} \hat{i} & \hat{j} & \hat{k} \\ \frac{\partial}{\partial x} & \frac{\partial}{\partial y} & \frac{\partial}{\partial z} \\ 2x - y - yz^2 & -y^2z & \end{vmatrix}$$

$$= (-2yz + 2yz)\hat{i} - (0 - 0)\hat{j} + (0 + 1)\hat{k} = \hat{k}$$

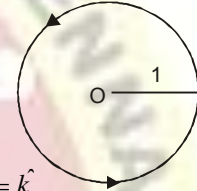

Putting the value of $\text{curl } \vec{F}$ in (1), we get

$$= \iint_s \hat{k} \cdot \hat{n} \, ds = \iint_s \hat{k} \cdot \hat{n} \frac{dx \, dy}{\hat{n} \cdot \hat{k}} = \iint_s dx \, dy = \text{Area of the circle} = \pi$$

$$\left[\cdot ds = \frac{dx \, dy}{(\hat{n} \cdot \hat{k})} \right]$$

Example 87. Evaluate $\int_c \vec{F} \cdot d\vec{r}$, where $F(x, y, z) = -y^2\hat{i} + x\hat{j} + z^2\hat{k}$ and C is the curve of intersection of the plane $y + z = 2$ and the cylinder $x^2 + y^2 = 1$. (Gujarat, I sem. Jan. 2009)

Solution. $\int_c \vec{F} \cdot d\vec{r} = \iint_s \text{curl } \vec{F} \cdot \hat{n} \, ds = \iint_s \text{curl}(-y^2\hat{i} + x\hat{j} + z^2\hat{k}) \cdot \hat{n} \, ds$... (1)

$$F(x, y, z) = -y^2\hat{i} + x\hat{j} + z^2\hat{k} \quad (\text{By Stoke's Theorem})$$

$$\text{Curl } \vec{F} = \begin{vmatrix} \hat{i} & \hat{j} & \hat{k} \\ \frac{\partial}{\partial x} & \frac{\partial}{\partial y} & \frac{\partial}{\partial z} \\ -y^2 & x & z^2 \end{vmatrix}$$

$$= \hat{i}(0 - 0) - \hat{j}(0 - 0) + \hat{k}(1 + 2y) = (1 + 2y)\hat{k}$$

Normal vector = ∇F

$$= \left(\hat{i} \frac{\partial}{\partial x} + \hat{j} \frac{\partial}{\partial y} + \hat{k} \frac{\partial}{\partial z} \right) (y + z - 2) = \hat{j} + \hat{k}$$

Unit normal vector $\hat{n} = \frac{\hat{j} + \hat{k}}{\sqrt{2}}$

$$ds = \frac{dx \, dy}{\hat{n} \cdot \hat{k}}$$

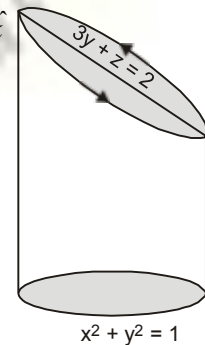

Vectors

On putting the values of $\text{curl } \vec{F}, \hat{n}$ and ds in (1), we get

$$\begin{aligned} \int_C \vec{F} \cdot d\vec{r} &= \iint_S (1+2y) \hat{k} \cdot \frac{\hat{j} + \hat{k}}{\sqrt{2}} \frac{dx dy}{\left(\frac{\hat{j} + \hat{k}}{\sqrt{2}}\right) \cdot \hat{i}} \\ &= \iint \frac{1+2y}{\sqrt{2}} \frac{dx dy}{\frac{1}{\sqrt{2}}} = \iint (1+2y) dx dy = \int_0^{2\pi} \int_0^1 (1+2r \sin \theta) r d\theta dr \\ &= \int_0^{2\pi} \int_0^1 (r + 2r^2 \sin \theta) d\theta dr \\ &= \int_0^{2\pi} d\theta \left[\frac{r^2}{2} + \frac{2r^3}{3} \sin \theta \right]_0^1 = \int_0^{2\pi} \left[\frac{1}{2} + \frac{2}{3} \sin \theta \right] d\theta \\ &= \left[\frac{\theta}{2} - \frac{2}{3} \cos \theta \right]_0^{2\pi} = \left(\pi - \frac{2}{3} - 0 + \frac{2}{3} \right) = \pi \quad \text{Ans.} \end{aligned}$$

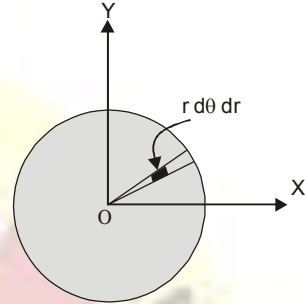

Example 88. Apply Stoke's Theorem to find the value of

$$\int_C (y dx + z dy + x dz)$$

where c is the curve of intersection of $x^2 + y^2 + z^2 = a^2$ and $x + z = a$. (Nagpur, Summer 2001)

Solution. $\int_C (y dx + z dy + x dz)$

$$\begin{aligned} &= \int_C (y\hat{i} + z\hat{j} + x\hat{k}) \cdot (\hat{i} dx + \hat{j} dy + \hat{k} dz) = \int_C (y\hat{i} + z\hat{j} + x\hat{k}) \cdot d\vec{r} \\ &= \iint_S \text{curl} (y\hat{i} + z\hat{j} + x\hat{k}) \cdot \hat{n} ds \quad \text{(By Stoke's Theorem)} \\ &= \iint_S \left(\hat{i} \frac{\partial}{\partial x} + \hat{j} \frac{\partial}{\partial y} + \hat{k} \frac{\partial}{\partial z} \right) \times (y\hat{i} + z\hat{j} + x\hat{k}) \cdot \hat{n} ds = \iint_S -(\hat{i} + \hat{j} + \hat{k}) \cdot \hat{n} ds \dots(1) \end{aligned}$$

where S is the circle formed by the intersection of $x^2 + y^2 + z^2 = a^2$ and $x + z = a$.

$$\hat{n} = \frac{\nabla \phi}{|\nabla \phi|} = \frac{\left(\hat{i} \frac{\partial}{\partial x} + \hat{j} \frac{\partial}{\partial y} + \hat{k} \frac{\partial}{\partial z} \right) (x + z - a)}{\left| \nabla \phi \right|} = \frac{\hat{i} + \hat{k}}{\sqrt{1+1}}$$

$$\therefore \hat{n} = \frac{\hat{i}}{\sqrt{2}} + \frac{\hat{k}}{\sqrt{2}}$$

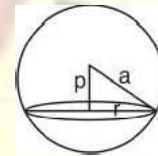

Putting the value of \hat{n} in (1), we have

$$\begin{aligned} &= \iint_S -(\hat{i} + \hat{j} + \hat{k}) \cdot \left(\frac{\hat{i}}{\sqrt{2}} + \frac{\hat{k}}{\sqrt{2}} \right) ds \\ &= \iint_S -\left(\frac{1}{\sqrt{2}} + \frac{1}{\sqrt{2}} \right) ds \quad \left[\text{Use } r^2 = R^2 - p^2 = a^2 - \frac{a^2}{2} = \frac{a^2}{2} \right] \\ &= \frac{-2}{\sqrt{2}} \iint_S ds = \frac{-2}{\sqrt{2}} \pi \left(\frac{a}{\sqrt{2}} \right)^2 = -\frac{\pi a^2}{\sqrt{2}} \quad \text{Ans.} \end{aligned}$$

Example 89. Directly or by Stoke's Theorem, evaluate $\iint_S \text{curl } \vec{v} \cdot \hat{n} ds$, $\vec{v} = \hat{i}y + \hat{j}z + \hat{k}x$, s is

the surface of the paraboloid $z = 1 - x^2 - y^2$, $z^3 \geq 0$ and \hat{n} is the unit vector normal to s .

Solution.
$$\nabla \times \vec{v} = \begin{vmatrix} \hat{i} & \hat{j} & \hat{k} \\ \frac{\partial}{\partial x} & \frac{\partial}{\partial y} & \frac{\partial}{\partial z} \\ y & z & x \end{vmatrix} = -\hat{i} - \hat{j} - \hat{k}$$

Obviously $\hat{n} = \hat{k}$.

Therefore $(\nabla \times \vec{v}) \cdot \hat{n} = (-\hat{i} - \hat{j} - \hat{k}) \cdot \hat{k} = -1$

Hence
$$\iint_S (\nabla \times \vec{v}) \cdot \hat{n} \, ds = \iint_S (-1) \, dx \, dy = - \iint_S dx \, dy$$

$$= -\pi (1)^2 = -\pi. \quad (\text{Area of circle} = \pi r^2) \text{ Ans.}$$

Example 90. Use Stoke's Theorem to evaluate $\int_c \vec{v} \cdot d\vec{r}$, where $\vec{v} = y^2\hat{i} + xy\hat{j} + xz\hat{k}$, and c is the bounding curve of the hemisphere $x^2 + y^2 + z^2 = 9, z > 0$, oriented in the positive direction.

Solution. By Stoke's theorem

$$\int_c \vec{v} \cdot d\vec{r} = \iint_S (\text{curl } \vec{v}) \cdot \hat{n} \, ds = \iint_S (\nabla \times \vec{v}) \cdot \hat{n} \, ds$$

$$\nabla \times \vec{v} = \begin{vmatrix} \hat{i} & \hat{j} & \hat{k} \\ \frac{\partial}{\partial x} & \frac{\partial}{\partial y} & \frac{\partial}{\partial z} \\ y^2 & xy & xz \end{vmatrix} = (0-0)\hat{i} - (z-0)\hat{j} + (y-2y)\hat{k}$$

$$= -z\hat{j} - y\hat{k}$$

$$\nabla \phi = \left(\hat{i} \frac{\partial}{\partial x} + \hat{j} \frac{\partial}{\partial y} + \hat{k} \frac{\partial}{\partial z} \right) (x^2 + y^2 + z^2 - 9)$$

$$\hat{n} = \frac{\nabla \phi}{|\nabla \phi|} = \frac{2x\hat{i} + 2y\hat{j} + 2z\hat{k}}{\sqrt{4x^2 + 4y^2 + 4z^2}} = \frac{x\hat{i} + y\hat{j} + z\hat{k}}{\sqrt{x^2 + y^2 + z^2}} = \frac{x\hat{i} + y\hat{j} + z\hat{k}}{3}$$

$$(\nabla \times \vec{v}) \cdot \hat{n} = (-z\hat{j} - y\hat{k}) \cdot \frac{x\hat{i} + y\hat{j} + z\hat{k}}{3} = \frac{-yz - yz - 2yz}{3} = \frac{-2yz}{3}$$

$$\hat{n} \cdot \hat{k} \, ds = dx \, dy \Rightarrow \frac{x\hat{i} + y\hat{j} + z\hat{k}}{3} \cdot \hat{k} \, ds = dx \, dy \Rightarrow \frac{z}{3} \, ds = dx \, dy$$

$\therefore ds = \frac{3}{z} dx \, dy$

$$\iint_S (\nabla \times \vec{v}) \cdot \hat{n} \, ds = \iint_S \left(\frac{-2yz}{3} \right) \left(\frac{3}{z} dx \, dy \right) = - \iint_S 2y \, dx \, dy$$

$$= - \int_0^{2\pi} \int_0^3 2r \sin \theta \, r \, dr \, d\theta = -2 \int_0^{2\pi} \sin \theta \, d\theta \int_0^3 r^2 \, dr$$

$$= -2 (-\cos \theta)^{2\pi}_0 \cdot \left[\frac{r^3}{3} \right]_0^3 = -2 (-1 + 1) 9 = 0 \text{ Ans.}$$

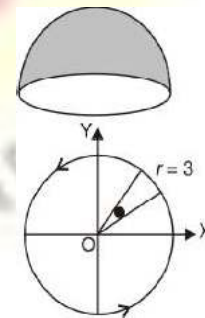

Example 91. Evaluate the surface integral $\iint_S \text{curl } F \cdot \hat{n} \, dS$ by transforming it into a line integral, S being that part of the surface of the paraboloid $z = 1 - x^2 - y^2$ for which $z \geq 0$ and $\vec{F} = y\hat{i} + z\hat{j} + x\hat{k}$. (K. University, Dec. 2008)

Vectors

Solution.

$$\vec{\nabla} \times \vec{F} = \begin{vmatrix} \hat{i} & \hat{j} & \hat{k} \\ \frac{\partial}{\partial x} & \frac{\partial}{\partial y} & \frac{\partial}{\partial z} \\ y & z & x \end{vmatrix} = -\hat{i} - \hat{j} - \hat{k}$$

Obviously $\hat{n} = \hat{k}$.

Therefore $(\vec{\nabla} \times \vec{F}) \cdot \hat{n} = (-\hat{i} - \hat{j} - \hat{k}) \cdot \hat{k} = -1$

Hence $\iint_S (\vec{\nabla} \times \vec{F}) \cdot \hat{n} \, ds = \iint_S (-1) \, dx \, dy = - \iint_S dx \, dy$
 $= -\pi (1)^2 = -\pi.$ (Area of circle = πr^2) **Ans.**

Example 92. Evaluate $\int_C \vec{F} \cdot d\vec{r}$ by Stoke's Theorem, where $\vec{F} = y \hat{i} + x \hat{j} - (x+z) \hat{k}$ and C is the boundary of triangle with vertices at $(0, 0, 0)$, $(1, 0, 0)$ and $(1, 1, 0)$.

(U.P., I Semester, Winter 2000)

Solution. We have, $\text{curl } \vec{F} = \vec{\nabla} \times \vec{F}$

$$= \begin{vmatrix} \hat{i} & \hat{j} & \hat{k} \\ \frac{\partial}{\partial x} & \frac{\partial}{\partial y} & \frac{\partial}{\partial z} \\ y^2 & x^2 & -(x+z) \end{vmatrix} = 0 \hat{i} + \hat{j} 2(x-y) \hat{k}.$$

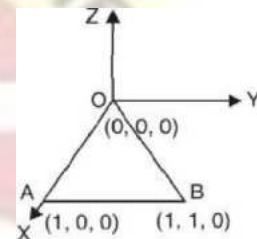

We observe that z co-ordinate of each vertex of the triangle is zero.

Therefore, the triangle lies in the xy -plane.

$$\therefore \hat{n} = \hat{k}$$

$$\therefore \text{curl } \vec{F} \cdot \hat{n} = [j + 2(x-y)k] \cdot k = 2(x-y).$$

In the figure, only xy -plane is considered.

The equation of the line OB is $y = x$

By Stoke's theorem, we have

$$\begin{aligned} \int_C \vec{F} \cdot d\vec{r} &= \iint_S (\text{curl } \vec{F} \cdot \hat{n}) \, ds \\ &= \int_{x=0}^1 \int_{y=0}^x 2(x-y) \, dx \, dy = 2 \int_0^1 \left[xy - \frac{y^2}{2} \right]_0^x dx \\ &= 2 \int_0^1 \left[x^2 - \frac{x^2}{2} \right] dx = 2 \int_0^1 \frac{x^2}{2} dx = \int_0^1 x^2 dx = \left[\frac{x^3}{3} \right]_0^1 = \frac{1}{3}. \end{aligned}$$

Ans.

Example 93. Evaluate $\int_C \vec{F} \cdot d\vec{r}$ by Stoke's Theorem, where $\vec{F} = (x^2 + y^2) \hat{i} - 2xy \hat{j}$ and C

is the boundary of the rectangle $x = \pm a$, $y = 0$ and $y = b$. (U.P., I Semester, Winter 2002)

Solution. Since the z co-ordinate of each vertex of the given rectangle is zero, hence the given rectangle must lie in the xy -plane.

Here, the co-ordinates of A , B , C and D are $(a, 0)$, (a, b) , $(-a, b)$ and $(-a, 0)$ respectively.

$$\therefore \text{Curl } \vec{F} = \begin{vmatrix} \hat{i} & \hat{j} & \hat{k} \\ \frac{\partial}{\partial x} & \frac{\partial}{\partial y} & \frac{\partial}{\partial z} \\ x^2 + y^2 & -2xy & 0 \end{vmatrix} = -4y \hat{k}$$

Here, $\hat{n} = \hat{k}$, so by Stoke's theorem, we've

$$\begin{aligned} \int_C \vec{F} \cdot d\vec{r} &= \iint_S \text{curl } \vec{F} \cdot \hat{n} \, ds \\ &= \iint_S (-4y\hat{k}) \cdot (\hat{k}) \, dx \, dy = -4 \int_{x=-a}^a \int_{y=0}^b y \, dx \, dy \\ &= -4 \int_{-a}^a \left[\frac{y^2}{2} \right]_0^b dx = -2b^2 \int_{-a}^a dx = -4ab^2 \end{aligned}$$

Ans.

Example 94. Apply Stoke's Theorem to calculate $\int_C 4y \, dx + 2z \, dy + 6y \, dz$ where c is the curve of intersection of $x^2 + y^2 + z^2 = 6z$ and $z = x + 3$.

Solution.

$$\begin{aligned} \int_C \vec{F} \cdot d\vec{r} &= \int_C 4y \, dx + 2z \, dy + 6y \, dz \\ &= \int_C (4y\hat{i} + 2z\hat{j} + 6y\hat{k}) \cdot (\hat{i} \, dx + \hat{j} \, dy + \hat{k} \, dz) \end{aligned}$$

$$\vec{F} = 4y\hat{i} + 2z\hat{j} + 6y\hat{k}$$

$$\nabla \times \vec{F} = \begin{vmatrix} \hat{i} & \hat{j} & \hat{k} \\ \frac{\partial}{\partial x} & \frac{\partial}{\partial y} & \frac{\partial}{\partial z} \\ 4y & 2z & 6y \end{vmatrix} = (6-2)\hat{i} - (0-0)\hat{j} + (0-4)\hat{k} = 4\hat{i} - 4\hat{k}$$

S is the surface of the circle $x^2 + y^2 + z^2 = 6z$, $z = x + 3$, \hat{n} is normal to the plane $x - z + 3 = 0$

$$\nabla \phi = \left(\hat{i} \frac{\partial}{\partial x} + \hat{j} \frac{\partial}{\partial y} + \hat{k} \frac{\partial}{\partial z} \right) (x - z + 3) = \hat{i} - \hat{k} \quad |\nabla \phi| = \sqrt{1+1} = \sqrt{2}$$

$$\hat{n} = \frac{\nabla \phi}{|\nabla \phi|} = \frac{\hat{i} - \hat{k}}{\sqrt{2}}$$

$$(\nabla \times \vec{F}) \cdot \hat{n} = (4\hat{i} - 4\hat{k}) \cdot \frac{\hat{i} - \hat{k}}{\sqrt{2}} = \frac{4+4}{\sqrt{2}} = 4\sqrt{2}$$

$$\int_C \vec{F} \cdot d\vec{r} = \iint_S (\text{curl } \vec{F}) \cdot \hat{n} \, ds = \iint_S 4\sqrt{2} \, (dx \, dz) = 4\sqrt{2} \text{ (area of circle)}$$

Centre of the sphere $x^2 + y^2 + (z - 3)^2 = 9$, $(0, 0, 3)$ lies on the plane $z = x + 3$. It means that the given circle is a great circle of sphere, where radius of the circle is equal to the radius of the sphere.

$$\text{Radius of circle} = 3, \text{ Area} = \pi(3)^2 = 9\pi$$

$$\iint_S (\nabla \times \vec{F}) \cdot \hat{n} \, ds = 4\sqrt{2}(9\pi) = 36\sqrt{2}\pi$$

Ans.

Example 95. Verify Stoke's Theorem for the function $\vec{F} = z\hat{i} + x\hat{j} + y\hat{k}$, where C is the unit circle in xy -plane bounding the hemisphere $z = \sqrt{1-x^2-y^2}$. (U.P., I Semester Comp. 2002)

Solution. Here $\vec{F} = z\hat{i} + x\hat{j} + y\hat{k}$ (1)

Also, $\vec{r} = x\hat{i} + y\hat{j} + z\hat{k} \Rightarrow d\vec{r} = dx\hat{i} + dy\hat{j} + dz\hat{k}$.

$\therefore \vec{F} \cdot d\vec{r} = z \, dx + x \, dy + y \, dz$.

$\therefore \int_C \vec{F} \cdot d\vec{r} = \int_C (z \, dx + x \, dy + y \, dz)$ (2)

Vectors

On the circle $C, x^2 + y^2 = 1, z = 0$ on the xy -plane. Hence on C , we have $z = 0$ so that $dz = 0$. Hence (2) reduces to

$$\int_C \vec{F} \cdot d\vec{r} = \int_C x \, dy \tag{3}$$

Now the parametric equations of C , i.e., $x^2 + y^2 = 1$ are

$$x = \cos \phi, \quad y = \sin \phi \tag{4}$$

$$\begin{aligned} \text{Using (4), (3) reduces to } \int_C \vec{F} \cdot d\vec{r} &= \int_{\phi=0}^{2\pi} \cos \phi \cos \phi \, d\phi = \int_0^{2\pi} \frac{1 + \cos 2\phi}{2} \, d\phi \\ &= \frac{1}{2} \left[\phi + \frac{\sin 2\phi}{2} \right]_0^{2\pi} = \pi \end{aligned} \tag{5}$$

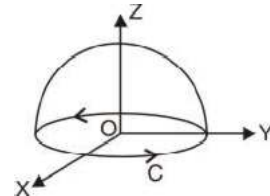

Let $P(x, y, z)$ be any point on the surface of the hemisphere $x^2 + y^2 + z^2 = 1$, O origin is the centre of the sphere.

Radius = $OP = x\hat{i} + y\hat{j} + z\hat{k}$ Normal = $x\hat{i} + y\hat{j} + z\hat{k}$

$$\hat{n} = \frac{x\hat{i} + y\hat{j} + z\hat{k}}{\sqrt{x^2 + y^2 + z^2}} = x\hat{i} + y\hat{j} + z\hat{k}$$

(Radius is \perp to tangent i.e. Radius is normal)

$$x = \sin \theta \cos \phi, \quad y = \sin \theta \sin \phi, \quad z = \cos \theta \tag{6}$$

$$\hat{n} = \sin \theta \cos \phi \hat{i} + \sin \theta \sin \phi \hat{j} + \cos \theta \hat{k}$$

Also,
$$\text{Curl } \vec{F} = \begin{vmatrix} \hat{i} & \hat{j} & \hat{k} \\ \partial/\partial x & \partial/\partial y & \partial/\partial z \\ z & x & y \end{vmatrix} = \hat{i} + \hat{j} + \hat{k} \tag{7}$$

$$\begin{aligned} \text{Curl } \vec{F} \cdot \hat{n} &= (\hat{i} + \hat{j} + \hat{k}) \cdot (\sin \theta \cos \phi \hat{i} + \sin \theta \sin \phi \hat{j} + \cos \theta \hat{k}) \\ &= \sin \theta \cos \phi + \sin \theta \sin \phi + \cos \theta \end{aligned}$$

$$\begin{aligned} \therefore \iint_S \text{Curl } \vec{F} \cdot \hat{n} \, dS &= \int_{\theta=0}^{\pi/2} \int_{\phi=0}^{2\pi} (\hat{i} + \hat{j} + \hat{k}) \cdot (\sin \theta \cos \phi \hat{i} + \sin \theta \sin \phi \hat{j} + \cos \theta \hat{k}) \sin \theta \, d\theta \, d\phi \\ &= \int_0^{\pi/2} \sin \theta \, d\theta \int_0^{2\pi} (\sin \theta \cos \phi + \sin \theta \sin \phi + \cos \theta) \, d\phi \\ &= \int_0^{\pi/2} \sin \theta \, d\theta [0 + 0 + 2\pi \cos \theta] = 2\pi \int_0^{\pi/2} \sin \theta \cos \theta \, d\theta \\ &= \pi \int_0^{\pi/2} \sin 2\theta \, d\theta = \pi \left[-\frac{\cos 2\theta}{2} \right]_0^{\pi/2} \\ &= -(\pi/2) [-1 - 1] = \pi. \end{aligned}$$

From (5) and (8), $\int_C \vec{F} \cdot d\vec{r} = \iint_S \text{curl } \vec{F} \cdot \hat{n} \, dS$, which verifies Stokes's theorem.

Example 96. Verify Stoke's theorem for the vector field $\vec{F} = (2x - y)\hat{i} - yz^2\hat{j} - y^2z\hat{k}$ over the upper half of the surface $x^2 + y^2 + z^2 = 1$ bounded by its projection on xy - plane. (Nagpur University, Summer 2001)

Solution. Let S be the upper half surface of the sphere $x^2 + y^2 + z^2 = 1$. The boundary C or S is a circle in the xy plane of radius unity and centre O . The equation of C are $x^2 + y^2 = 1, z = 0$ whose parametric form is

$$x = \cos t, \quad y = \sin t, \quad z = 0, \quad 0 < t < 2\pi$$

$$\int_C \vec{F} \cdot d\vec{r} = \int_C [(2x - y)\hat{i} - yz^2\hat{j} - y^2z\hat{k}] \cdot [\hat{i} \, dx + \hat{j} \, dy + \hat{k} \, dz]$$

Vectors

$$\begin{aligned}
 &= \int_C [(2x - y) dx - yz^2 dy - y^2 z dz] = \int_C (2x - y) dx, \text{ since on } C, z = 0 \text{ and } 2z = 0 \\
 &= \int_0^{2\pi} (2 \cos t - \sin t) \frac{dx}{dt} dt = \int_0^{2\pi} (2 \cos t - \sin t) (-\sin t) dt \\
 &= \int_0^{2\pi} (-\sin 2t + \sin^2 t) dt = \int_0^{2\pi} \left(-\sin 2t + \frac{1 - \cos 2t}{2} \right) dt \\
 &= \left[\frac{\cos 2t}{2} - t + \frac{\sin 2t}{4} \right]_0^{2\pi} = \frac{1}{2} + \pi - \frac{1}{2} = \pi \quad \dots(1)
 \end{aligned}$$

$$\text{Curl } \vec{F} = \begin{vmatrix} \hat{i} & \hat{j} & \hat{k} \\ \frac{\partial}{\partial x} & \frac{\partial}{\partial y} & \frac{\partial}{\partial z} \\ 2x - y & -yz^2 & -y^2 z \end{vmatrix} = (-2yz + 2yz)\hat{i} + (0 - 0)\hat{j} + (0 + 1)\hat{k} = \hat{k}$$

$$\iint_S \text{Curl } \vec{F} \cdot \vec{n} \, ds = \iint_S \hat{k} \cdot \hat{n} \, ds = \iint_S \hat{n} \cdot \hat{k} \, ds = \iint_R \hat{n} \cdot \hat{k} \, dx \, dy$$

Where R is the projection of S on xy-plane.

$$\begin{aligned}
 &= \int_{-1}^1 \int_{-\sqrt{1-x^2}}^{\sqrt{1-x^2}} dx \, dy = \int_{-1}^1 2 \sqrt{1-x^2} \, dx = 4 \int_0^1 \sqrt{1-x^2} \, dx \\
 &= 4 \left[\frac{x}{2} \sqrt{1-x^2} + \frac{1}{2} \sin^{-1} x \right]_0^1 = 4 \left[\frac{1}{2} \frac{\pi}{2} \right] = \pi \quad \dots(2)
 \end{aligned}$$

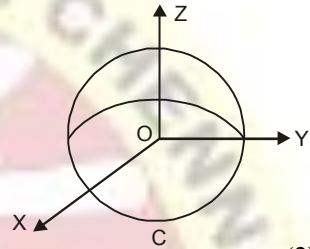

From (1) and (2), we have

$$\therefore \int_C \vec{F} \cdot d\vec{r} = \iint_S \text{Curl } \vec{F} \cdot \vec{n} \, ds \text{ which is the Stoke's theorem.}$$

Ans.

Example 97. Verify Stoke's Theorem for $\vec{F} = (x^2 + y - 4)\hat{i} + 3xy\hat{j} + (2xz + z^2)\hat{k}$ over the surface of hemisphere $x^2 + y^2 + z^2 = 16$ above the xy-plane.

Solution. $\int_C \vec{F} \cdot d\vec{r}$, where c is the boundary of the circle $x^2 + y^2 + z^2 = 16$ (bounding the hemispherical surface)

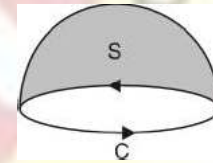

$$\begin{aligned}
 &= \int_C [(x^2 + y - 4)\hat{i} + 3xy\hat{j} + (2xz + z^2)\hat{k}] \cdot (\hat{i} dx + \hat{j} dy) \\
 &= \int_C [(x^2 + y - 4) dx + 3xy dy] \\
 \text{Putting } x &= 4 \cos \theta, y = 4 \sin \theta, dx = -4 \sin \theta d\theta, dy = 4 \cos \theta d\theta \\
 &= \int_0^{2\pi} [(16 \cos^2 \theta + 4 \sin \theta - 4)(-4 \sin \theta d\theta) + (192 \sin \theta \cos^2 \theta d\theta)] \\
 &= 16 \int_0^{2\pi} [-4 \cos^2 \theta \sin \theta - \sin^2 \theta + \sin \theta + 12 \sin \theta \cos^2 \theta] d\theta \\
 &= 16 \int_0^{2\pi} (8 \sin \theta \cos^2 \theta - \sin^2 \theta + \sin \theta) d\theta \quad \left\{ \begin{array}{l} \int_0^{2\pi} \sin^n \theta \cos \theta d\theta = 0 \\ \int_0^{2\pi} \cos^n \theta \sin \theta d\theta = 0 \end{array} \right. \\
 &= -16 \int_0^{2\pi} \sin^2 \theta d\theta \\
 &= -16 \times 4 \int_0^{\frac{\pi}{2}} \sin^2 \theta d\theta = -64 \left(\frac{1}{2} \frac{\pi}{2} \right) = -16 \pi.
 \end{aligned}$$

To evaluate surface integral $\nabla \times \vec{F} = \begin{vmatrix} \hat{i} & \hat{j} & \hat{k} \\ \frac{\partial}{\partial x} & \frac{\partial}{\partial y} & \frac{\partial}{\partial z} \\ x^2 + y - 4 & 3xy & 2xz + z^2 \end{vmatrix}$

Vectors

$$\begin{aligned}
 &= (0-0)\hat{i} - (2z-0)\hat{j} + (3y-1)\hat{k} = -2z\hat{j} + (3y-1)\hat{k} \\
 \nabla\phi &= \left(\hat{i}\frac{\partial}{\partial x} + \hat{j}\frac{\partial}{\partial y} + \hat{k}\frac{\partial}{\partial z} \right) (x^2 + y^2 + z^2 - 16) \\
 \hat{n} &= \frac{|\nabla\phi|}{|\nabla\phi|} = \frac{2x\hat{i} + 2y\hat{j} + 2z\hat{k}}{\sqrt{4x^2 + 4y^2 + 4z^2}} = \frac{x\hat{i} + y\hat{j} + z\hat{k}}{\sqrt{x^2 + y^2 + z^2}} = \frac{x\hat{i} + y\hat{j} + z\hat{k}}{4} \\
 (\nabla \times \vec{F}) \cdot \hat{n} &= [-2z\hat{j} + (3y-1)\hat{k}] \cdot \frac{x\hat{i} + y\hat{j} + z\hat{k}}{4} = \frac{-2yz + (3y-1)z}{4} \\
 \hat{k} \cdot \hat{n} \, ds &= dx \, dy \Rightarrow \frac{x\hat{i} + y\hat{j} + z\hat{k}}{4} \cdot \hat{k} \, ds = dx \, dy \Rightarrow \frac{z}{4} \, ds = dx \, dy \\
 \therefore \iint (\nabla \times \vec{F}) \cdot \hat{n} \, ds &= \iint \frac{-2yz + (3y-1)z}{4} \left(\frac{4}{z} \, dx \, dy \right) = \iint [-2y + (3y-1)] \, dx \, dy = \iint (y-1) \, dx \, dy
 \end{aligned}$$

On putting $x = r \cos \theta$, $y = r \sin \theta$, $dx \, dy = r \, d\theta \, dr$, we get

$$\begin{aligned}
 &= \iint (r \sin \theta - 1) r \, d\theta \, dr = \int d\theta \int (r^2 \sin \theta - r) \, dr \\
 &= \int_0^{2\pi} d\theta \left(\frac{r^3}{3} \sin \theta - \frac{r^2}{2} \right)_0^4 = \int_0^{2\pi} d\theta \left(\frac{64}{3} \sin \theta - 8 \right) \\
 &= \left(-\frac{64}{3} \cos \theta - 8\theta \right)_0^{2\pi} = -\frac{64}{3} - 16\pi + \frac{64}{3} = -16\pi
 \end{aligned}$$

The line integral is equal to the surface integral, hence Stoke's Theorem is verified. **Proved.**

Example 98. Verify Stoke's theorem for a vector field defined by $\vec{F} = (x^2 - y^2)\hat{i} + 2xy\hat{j}$ in the rectangular in xy -plane bounded by lines $x = 0$, $x = a$, $y = 0$, $y = b$.
(Nagpur University, Summer 2000)

Solution. Here we have to verify Stoke's theorem $\int_C \vec{F} \cdot d\vec{r} = \iint_S (\nabla \times \vec{F}) \cdot \hat{n} \, ds$
Where 'C' be the boundary of rectangle (ABCD) and S be the surface enclosed by curve C.

$$\vec{F} = (x^2 - y^2)\hat{i} + (2xy)\hat{j}$$

$$\vec{F} \cdot d\vec{r} = [(x^2 - y^2)\hat{i} + 2xy\hat{j}] \cdot [dx\hat{i} + dy\hat{j}]$$

$$\Rightarrow \vec{F} \cdot d\vec{r} = (x^2 + y^2) \, dx + 2xy \, dy \quad \dots(1)$$

$$\text{Now, } \int_C \vec{F} \cdot d\vec{r} = \int_{OA} \vec{F} \cdot d\vec{r} + \int_{AB} \vec{F} \cdot d\vec{r} + \int_{BC} \vec{F} \cdot d\vec{r} + \int_{CO} \vec{F} \cdot d\vec{r} \quad \dots(2)$$

Along OA, put $y = 0$ so that $k \, dy = 0$ in (1) and $\vec{F} \cdot d\vec{r} = x^2 \, dx$,

Where x is from 0 to a .

$$\therefore \int_{OA} \vec{F} \cdot d\vec{r} = \int_0^a x^2 \, dx = \left[\frac{x^3}{3} \right]_0^a = \frac{a^3}{3} \quad \dots(3)$$

Along AB, put $x = a$ so that $dx = 0$ in (1), we get $\vec{F} \cdot d\vec{r} = 2ay \, dy$

Where y is from 0 to b .

$$\therefore \int_{AB} \vec{F} \cdot d\vec{r} = \int_0^b 2ay \, dy = [ay^2]_0^b = ab \quad \dots(4)$$

Vectors

Along BC, put $y = b$ and $dy = 0$ in (1) we get $\vec{F} \cdot \vec{dr} = (x^2 - b^2) dx$, where x is from a to 0 .

$$\therefore \int_{BC} \vec{F} \cdot \vec{dr} = \int_a^0 (x^2 - b^2) dx = \left[\frac{x^3}{3} - b^2x \right]_a^0 = \frac{-a^3}{3} + b^2a \quad \dots(5)$$

Along CO, put $x = 0$ and $dx = 0$ in (1), we get $\vec{F} \cdot \vec{dr} = 0$

$$\therefore \int_{CO} \vec{F} \cdot \vec{dr} = 0 \quad \dots(6)$$

Putting the values of integrals (3), (4), (5) and (6) in (2), we get

$$\int_C \vec{F} \cdot \vec{dr} = \frac{a^3}{3} + ab^2 - \frac{a^3}{3} + ab^2 + 0 = 2ab^2 \quad \dots(7)$$

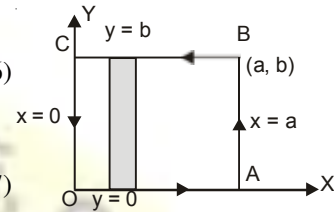

Now we have to evaluate R.H.S. of Stoke's Theorem i.e. $\iint_S (\nabla \times \vec{F}) \cdot \hat{n} ds$
We have,

$$\nabla \times \vec{F} = \begin{vmatrix} \hat{i} & \hat{j} & \hat{k} \\ \frac{\partial}{\partial x} & \frac{\partial}{\partial y} & \frac{\partial}{\partial z} \\ x^2 - y^2 & 2xy & 0 \end{vmatrix} = (2y + 2y) \hat{k} = 4y \hat{k}$$

Also the unit vector normal to the surface S in outward direction is $\hat{n} = \hat{k}$
(z -axis is normal to surface S)

$$\therefore \iint_S (\nabla \times \vec{F}) \cdot \hat{n} ds = \iint_R 4y \hat{k} \cdot \hat{k} dx dy = \iint_R 4y dx dy.$$

Where R be the region of the surface S .

Consider a strip parallel to y -axis. This strip starts on line $y = 0$ (i.e. x -axis) and end on the line $y = b$. We move this strip from $x = 0$ (y -axis) to $x = a$ to cover complete region R .

$$\therefore \iint_S (\nabla \times \vec{F}) \cdot \hat{n} ds = \int_0^a \int_0^b 4y dy dx = \int_0^a [2y^2]_0^b dx = \int_0^a 2b^2 dx = 2b^2 [x]_0^a = 2ab^2 \quad \dots(8)$$

\therefore From (7) and (8), we get

$$\int_C \vec{F} \cdot \vec{dr} = \iint_S (\nabla \times \vec{F}) \cdot \hat{n} ds \text{ and hence the Stoke's theorem is verified.}$$

Example 99. Verify Stoke's Theorem for the function

$\vec{F} = x^2\hat{i} - xy\hat{j}$
integrated round the square in the plane $z = 0$ and bounded by the lines $x = 0, y = 0, x = a, y = a$.

Solution. We have, $\vec{F} = x^2\hat{i} - xy\hat{j}$

$$\nabla \times \vec{F} = \begin{vmatrix} \hat{i} & \hat{j} & \hat{k} \\ \frac{\partial}{\partial x} & \frac{\partial}{\partial y} & \frac{\partial}{\partial z} \\ x^2 & -xy & 0 \end{vmatrix} = (0-0)\hat{i} - (0-0)\hat{j} + (-y-0)\hat{k} = -y\hat{k}$$

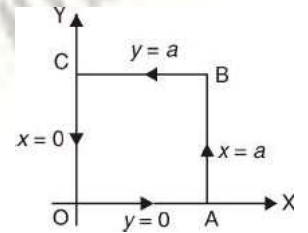

($\hat{n} \perp$ to xy plane i.e. \hat{k})

Vectors

$$\begin{aligned} \iint_S (\nabla \times \vec{F}) \cdot \hat{n} \, ds &= \iint_S (-yk) \cdot k \, dx \, dy \\ &= \int_0^a dx \int_0^a -y \, dy = \int_0^a dx \left[-\frac{y^2}{2} \right]_0^a = -\frac{a^2}{2} (x)_0^a = -\frac{a^3}{2} \end{aligned} \quad \dots(1)$$

To obtain line integral

$$\int_C \vec{F} \cdot d\vec{r} = \int_C (x^2 \hat{i} - xy \hat{j}) \cdot (\hat{i} \, dx + \hat{j} \, dy) = \int_C (x^2 \, dx - xy \, dy)$$

where c is the path $OABCO$ as shown in the figure.

$$\text{Also, } \int_C \vec{F} \cdot d\vec{r} = \int_{OABCO} \vec{F} \cdot d\vec{r} = \int_{OA} \vec{F} \cdot d\vec{r} + \int_{AB} \vec{F} \cdot d\vec{r} + \int_{BC} \vec{F} \cdot d\vec{r} + \int_{CO} \vec{F} \cdot d\vec{r} \quad \dots(2)$$

Along OA , $y = 0, dy = 0$

$$\begin{aligned} \int_{OA} \vec{F} \cdot d\vec{r} &= \int_{OA} (x^2 dx - xy dy) \\ &= \int_0^a x^2 dx = \left[\frac{x^3}{3} \right]_0^a = \frac{a^3}{3} \end{aligned}$$

Along AB , $x = a, dx = 0$

$$\begin{aligned} \int_{AB} \vec{F} \cdot d\vec{r} &= \int_{AB} (x^2 dx - xy dy) \\ &= \int_0^a -a y \, dy = -a \left[\frac{y^2}{2} \right]_0^a = -\frac{a^3}{2} \end{aligned}$$

Along BC , $y = a, dy = 0$

$$\int_{BC} \vec{F} \cdot d\vec{r} = \int_{BC} (x^2 dx - xy dy) = \int_a^0 x^2 dx = \left[\frac{x^3}{3} \right]_a^0 = -\frac{a^3}{3}$$

Along CO , $x = 0, dx = 0$

$$\int_{CO} \vec{F} \cdot d\vec{r} = \int_{CO} (x^2 dx - xy dy) = 0$$

Putting the values of these integrals in (2), we have

$$\int_C \vec{F} \cdot d\vec{r} = \frac{a^3}{3} - \frac{a^3}{2} - \frac{a^3}{3} + 0 = -\frac{a^3}{2} \quad \dots(3)$$

$$\text{From (1) and (3), } \iint_S (\nabla \times \vec{F}) \cdot \hat{n} \, ds = \int_C \vec{F} \cdot d\vec{r}$$

Hence, Stoke's Theorem is verified.

Ans.

Example 100. Verify Stoke's Theorem for $\vec{F} = (x + y) \hat{i} + (2x - z) \hat{j} + (y + z) \hat{k}$ for the surface of a triangular lamina with vertices $(2, 0, 0), (0, 3, 0)$ and $(0, 0, 6)$.

(Nagpur University 2004, K. U. Dec. 2009, 2008, A.M.I.E.T.E., Summer 2000)

Solution. Here the path of integration c consists of the straight lines AB, BC, CA where the co-ordinates of A, B, C and $(2, 0, 0), (0, 3, 0)$ and $(0, 0, 6)$ respectively. Let S be the plane surface of triangle ABC bounded by C . Let \hat{n} be unit normal vector to surface S . Then by Stoke's Theorem, we must have

$$\int_C \vec{F} \cdot d\vec{r} = \iint_S \text{curl } \vec{F} \cdot \hat{n} \, ds \quad \dots(1)$$

Vectors

$$\text{L.H.S. of (1)} = \int_{ABC}^c \vec{F} \cdot d\vec{r} = \int_{AB} \vec{F} \cdot d\vec{r} + \int_{BC} \vec{F} \cdot d\vec{r} + \int_{CA} \vec{F} \cdot d\vec{r}$$

Along line AB, $z = 0$, equation of AB is $\frac{x}{2} + \frac{y}{3} = 1$

$$\Rightarrow y = \frac{3}{2}(2-x), dy = -\frac{3}{2}dx$$

At A, $x = 2$, At B, $x = 0$, $\vec{r} = x\hat{i} + y\hat{j}$

$$\begin{aligned} \int_{AB} \vec{F} \cdot d\vec{r} &= \int_{AB} [(x+y)\hat{i} + 2x\hat{j} + y\hat{k}] \cdot (\hat{i}dx + \hat{j}dy) \\ &= \int_{AB} \left(\frac{x+y}{2} dx + 2x \left(-\frac{3}{2}dx\right) \right) \\ &= \int_2^0 \left(-\frac{7x}{2} + 3 \right) dx = \left(-\frac{7x^2}{4} + 3x \right)_2^0 \\ &= (7-6) = +1 \end{aligned}$$

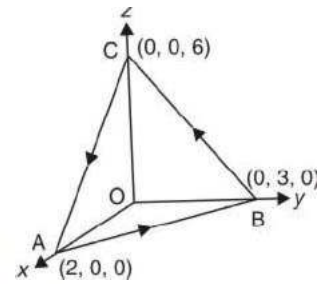

line	Eq. of line		Lower limit	Upper limit
AB	$\frac{x}{2} + \frac{y}{3} = 1$ $z = 0$	$dy = -\frac{3}{2}dx$	At A $x = 2$	At B $x = 0$
BC	$\frac{y}{3} + \frac{z}{6} = 1$ $x = 0$	$dz = -2dy$	At B $y = 3$	At C $y = 0$
CA	$\frac{x}{2} + \frac{z}{6} = 1$ $y = 0$	$dz = -3dx$	At C $x = 0$	At A $x = 2$

Along line BC, $x = 0$, Equation of BC is $\frac{y}{3} + \frac{z}{6} = 1$ or $z = 6 - 2y$, $dz = -2dy$

At B, $y = 3$, At C, $y = 0$, $\vec{r} = y\hat{j} + z\hat{k}$

$$\begin{aligned} \int_{BC} \vec{F} \cdot d\vec{r} &= \int_{BC} [yi\hat{i} + z\hat{j} + (y+z)\hat{k}] \cdot (jdy + kdz) = \int_{BC} -zdy + (y+z)dz \\ &= \int_3^0 (-6+2y)dy + (y+6-2y)(-2dy) \\ &= \int_3^0 (4y-18)dy = (2y^2-18y)_3^0 = 36 \end{aligned}$$

Along line CA, $y = 0$, Eq. of CA, $\frac{x}{2} + \frac{z}{6} = 1$ or $z = 6 - 3x$, $dz = -3dx$

At C, $x = 0$, at A, $x = 2$, $\vec{r} = x\hat{i} + z\hat{k}$

$$\begin{aligned} \int_{CA} \vec{F} \cdot d\vec{r} &= \int_{CA} [x\hat{i} + (2x-z)\hat{j} + z\hat{k}] \cdot [dx\hat{i} + dz\hat{k}] = \int_{CA} (xdx + zdz) \\ &= \int_0^2 xdx + (6-3x)(-3dx) = \int_0^2 (10x-18)dx = [5x^2-18x]_0^2 = -16 \end{aligned}$$

Vectors

$$\text{L.H.S. of (1)} = \int_{ABC} \vec{F} \cdot d\vec{r} = \int_{AB} \vec{F} \cdot d\vec{r} + \int_{BC} \vec{F} \cdot d\vec{r} + \int_{CA} \vec{F} \cdot d\vec{r} = 1 + 36 - 16 = 21 \quad \dots(2)$$

$$\text{Curl } \vec{F} = \nabla \times \vec{F} = \begin{vmatrix} \hat{i} & \hat{j} & \hat{k} \\ \frac{\partial}{\partial x} & \frac{\partial}{\partial y} & \frac{\partial}{\partial z} \\ (x+y) & (2x-z) & (y+z) \end{vmatrix}$$

$$= \begin{vmatrix} \hat{i} & \hat{j} & \hat{k} \\ \frac{\partial}{\partial x} & \frac{\partial}{\partial y} & \frac{\partial}{\partial z} \\ x+y & 2x-z & y+z \end{vmatrix} = (1+1)\hat{i} - (0-0)\hat{j} + (2-1)\hat{k} = 2\hat{i} + \hat{k}$$

$$\text{Equation of the plane of ABC is } \frac{x}{2} + \frac{y}{3} + \frac{z}{6} = 1$$

Normal to the plane ABC is

$$\nabla \phi = \left(\hat{i} \frac{\partial}{\partial x} + \hat{j} \frac{\partial}{\partial y} + \hat{k} \frac{\partial}{\partial z} \right) \left(\frac{x}{2} + \frac{y}{3} + \frac{z}{6} - 1 \right) = \frac{\hat{i}}{2} + \frac{\hat{j}}{3} + \frac{\hat{k}}{6}$$

$$\text{Unit Normal Vector} = \frac{\frac{\hat{i}}{2} + \frac{\hat{j}}{3} + \frac{\hat{k}}{6}}{\sqrt{\frac{1}{4} + \frac{1}{9} + \frac{1}{36}}}$$

$$n^{\wedge} = \frac{1}{\sqrt{14}} (3\hat{i} + 2\hat{j} + \hat{k})$$

$$\begin{aligned} \text{R.H.S. of (1)} &= \iint_s \text{curl } \vec{F} \cdot n^{\wedge} ds = \iint_s (2\hat{i} + \hat{k}) \cdot \frac{1}{\sqrt{14}} (3\hat{i} + 2\hat{j} + \hat{k}) \frac{dx dy}{\sqrt{14} (3i + 2j + k).k} \\ &= \iint_s \frac{(6+1)}{\sqrt{14}} \frac{dx dy}{1} = 7 \iint dx dy = 7 \text{ Area of } \Delta \text{ OAB} \\ &= 7 \left(\frac{1}{2} \times 2 \times 3 \right) = 21 \quad \dots(3) \end{aligned}$$

with the help of (2) and (3) we find (1) is true and so Stoke's Theorem is verified.

Example 101. Verify Stoke's Theorem for

$$\vec{F} = (y-z+2)\hat{i} + (yz+4)\hat{j} - (xz)\hat{k}$$

over the surface of a cube $x=0, y=0, z=0, x=2, y=2, z=2$ above the XOY plane (open the bottom).

Solution. Consider the surface of the cube as shown in the figure. Bounding path is OABCO shown by arrows.

$$\begin{aligned} \int_c \vec{F} \cdot d\vec{r} &= \int [(y-z+2)\hat{i} + (yz+4)\hat{j} - (xz)\hat{k}] \cdot (dx + dy + dz) \\ &= \int_c (y-z+2) dx + (yz+4) dy - xz dz \end{aligned}$$

$$\int_c \vec{F} \cdot d\vec{r} = \int_{OA} \vec{F} \cdot d\vec{r} + \int_{AB} \vec{F} \cdot d\vec{r} + \int_{BC} \vec{F} \cdot d\vec{r} + \int_{CO} \vec{F} \cdot d\vec{r} \quad \dots(1)$$

(1) Along OA, $y=0, dy=0, z=0, dz=0$

	Line	Equ. of line		Lower limit	Upper limit	$F \cdot dr$
1	OA	$y = 0$ $z = 0$	$dy = 0$ $dz = 0$	$x = 0$	$x = 2$	$2 dx$
2	AB	$x = 2$ $z = 0$	$dx = 0$ $dz = 0$	$y = 0$	$y = 2$	$4 dy$
3	BC	$y = 2$ $z = 0$	$dy = 0$ $dz = 0$	$x = 2$	$x = 0$	$4 dx$
4	CO	$x = 0$ $z = 0$	$dx = 0$ $dz = 0$	$y = 2$	$y = 0$	$4 dy$

$$\int_{OA}^{\rightarrow} F \cdot dr = \int_0^2 2 dx = [2x]_0^2 = 4$$

(2) Along AB , $x = 2$, $dx = 0$, $z = 0$, $dz = 0$

$$\int_{AB}^{\rightarrow} F \cdot dr = \int_0^2 4 dy = 4(y)_0^2 = 8$$

(3) Along BC , $y = 2$, $dy = 0$, $z = 0$, $dz = 0$

$$\int_{BC}^{\rightarrow} F \cdot dr = \int_0^2 (2 - 0 + 2) dx = (4x)_2^0 = -8$$

(4) Along CO , $x = 0$, $dx = 0$, $z = 0$, $dz = 0$

$$\begin{aligned} \int_{CO}^{\rightarrow} F \cdot dr &= \int (y - 0 + 2) \times 0 + (0 + 4) dy - 0 \\ &= 4 \int dy = 4(y)_2^0 = -8 \end{aligned}$$

On putting the values of these integrals in (1), we get

$$\int_c^{\rightarrow} F \cdot dr = 4 + 8 - 8 - 8 = -4$$

To obtain surface integral

$$\nabla \times \vec{F} = \begin{vmatrix} \hat{i} & \hat{j} & \hat{k} \\ \frac{\partial}{\partial x} & \frac{\partial}{\partial y} & \frac{\partial}{\partial z} \\ y - z + 2 & yz + 4 & -xz \end{vmatrix}$$

$$= (0 - y) \hat{i} - (-z + 1) \hat{j} + (0 - 1) \hat{k} = -y \hat{i} + (z - 1) \hat{j} - \hat{k}$$

Here we have to integrate over the five surfaces, $ABDE$, $OCGF$, $BCGD$, $OAEF$, $DEFG$.

Over the surface $ABDE$ ($x = 2$), $\hat{n} = \hat{i}$, $ds = dy dz$

$$\begin{aligned} \iint (\nabla \times \vec{F}) \cdot \hat{n} ds &= \iint [F(x, y, z)]_{z=f_1(x, y)}^{z=f_2(x, y)} \hat{i} \cdot \hat{i} dx dz = \iint -y dy dz \\ &= \iint_R -y dy dz \end{aligned}$$

Vectors

	Surface	Outward normal	ds	
1	ABDE	i	$dy dz$	$x = 2$
2	OCGF	$-i$	$dy dz$	$x = 0$
3	BCGD	j	$dx dz$	$y = 2$
4	OAEF	$-j$	$dx dz$	$y = 0$
5	DEFG	k	$dx dy$	$z = 2$

$$= - \int_0^2 y dy \int_0^2 dz = - \left[\frac{y^2}{2} \right]_0^2 [z]_0^2 = -4$$

Over the surface OCGF ($x = 0$), $\hat{n} = -i$, $ds = dy dz$

$$\begin{aligned} \iint (\nabla \times \vec{F}) \cdot \hat{n} ds &= \iint [-y\hat{i} + (z-1)\hat{j} - \hat{k}] \cdot (-\hat{i}) dy dz \\ &= \iint y dy dz = \int_0^2 y dy \int_0^2 dz = 2 \left[\frac{y^2}{2} \right]_0^2 = 4 \end{aligned}$$

(3) Over the surface BCGD, ($y = 2$), $\hat{n} = j$, $ds = dx dz$

$$\begin{aligned} \iint (\nabla \times \vec{F}) \cdot \hat{n} ds &= \iint [-y\hat{i} + (z-1)\hat{j} - \hat{k}] \cdot \hat{j} dx dz \\ &= - \iint (z-1) dx dz = \int_0^2 dx \int_0^2 (z-1) dz = -(x)_0^2 \left[\frac{z^2}{2} - z \right]_0^2 = 0 \end{aligned}$$

(4) Over the surface OAEF, ($y = 0$), $\hat{n} = -\hat{j}$, $ds = dx dz$

$$\begin{aligned} \iint (\nabla \times \vec{F}) \cdot \hat{n} ds &= \iint [-y\hat{i} + (z-1)\hat{j} - \hat{k}] \cdot (-\hat{j}) dx dz \\ &= - \iint (z-1) dx dz = - \int_0^2 dx \int_0^2 (z-1) dz = -(x)_0^2 \left[\frac{z^2}{2} - z \right]_0^2 = 0 \end{aligned}$$

(5) Over the surface DEFG, ($z = 2$), $\hat{n} = k$, $ds = dx dy$

$$\begin{aligned} \iint (\nabla \times \vec{F}) \cdot \hat{n} ds &= \iint [-y\hat{i} + (z-1)\hat{j} - \hat{k}] \cdot \hat{k} dx dy = - \iint dx dy \\ &= - \int_0^2 dx \int_0^2 dy = -[x]_0^2 [y]_0^2 = -4 \end{aligned}$$

Total surface integral = $-4 + 4 + 0 + 0 - 4 = -4$

$$\text{Thus } \iint_S \text{curl } \vec{F} \cdot \hat{n} ds = \int_C \vec{F} \cdot d\vec{r} = -4$$

which verifies Stoke's Theorem.

Ans.

EXERCISE 5.14

- Use the Stoke's Theorem to evaluate $\int_C y^2 dx + xy dy + xz dz$,
where C is the bounding curve of the hemisphere $x^2 + y^2 + z^2 = 1, z \geq 0$, oriented in the positive direction. **Ans.** 0
- Evaluate $\int_S (\text{curl } F) \cdot \hat{n} dA$, using the Stoke's Theorem, where $\vec{F} = y\hat{i} + z\hat{j} + x\hat{k}$ and S is the paraboloid $z = f(x, y) = 1 - x^2 - y^2, z \geq 0$. **Ans.** π
- Evaluate the integral for $\int_C y^2 dx + z^2 dy + x^2 dz$, where C is the triangular closed path joining the points $(0, 0, 0), (0, a, 0)$ and $(0, 0, a)$ by transforming the integral to surface integral using Stoke's Theorem. **Ans.** $\frac{a^3}{3}$.
- Verify Stoke's Theorem for $\vec{A} = 3y\hat{i} - xz\hat{j} + yz^2\hat{k}$, where S is the surface of the paraboloid $2z = x^2 + y^2$ bounded by $z = 2$ and c is its boundary traversed in the clockwise direction. **Ans.** $-\frac{20}{19}\pi$
- Evaluate $\int_C \vec{F} \cdot d\vec{R}$ where $\vec{F} = y\hat{i} + xz\hat{j} - zy\hat{k}$, C is the circle $x^2 + y^2 = 4, z = 1.5$. **Ans.** $\frac{\pi}{2}$
- If S is the surface of the sphere $x^2 + y^2 + z^2 = 9$. Prove that $\int_S \text{curl } \vec{F} \cdot d\vec{s} = 0$.
- Verify Stoke's Theorem for the vector field $\vec{F} = (2y + z)\hat{i} + (x - z)\hat{j} + (y - x)\hat{k}$ over the portion of the plane $x + y + z = 1$ cut off by the co-ordinate planes.
- Evaluate $\int_C \vec{F} \cdot d\vec{r}$ by Stoke's Theorem for $\vec{F} = yz\hat{i} + zx\hat{j} + xy\hat{k}$ and C is the curve of intersection of $x^2 + y^2 = 1$ and $z = \frac{2}{3}$. **Ans.** 0
- If $\vec{F} = (x - z)\hat{i} + (x + yz)\hat{j} + 3xy\hat{k}$ and S is the surface of the cone $z = a - \sqrt{x^2 + y^2}$ above the xy -plane, show that $\iint_S \text{curl } \vec{F} \cdot d\vec{S} = 3\pi a^4 / 4$.
- If $\vec{F} = 3y\hat{i} - xy\hat{j} + yz^2\hat{k}$ and S is the surface of the paraboloid $2z = x^2 + y^2$ bounded by $z = 2$, show by using Stoke's Theorem that $\iint_S (\nabla \times \vec{F}) \cdot d\vec{S} = 20\pi$.
- If $\vec{F} = (y^2 + z^2 - x^2)\hat{i} + (z^2 + x^2 - y^2)\hat{j} + (x^2 + y^2 - z^2)\hat{k}$, evaluate $\int_C \vec{F} \cdot \hat{n} ds$ integrated over the portion of the surface $x^2 + y^2 - 2ax + az = 0$ above the plane $z = 0$ and verify Stoke's Theorem; where \hat{n} is unit vector normal to the surface. (A.M.I.E.T.E., Winter 20002) **Ans.** $2\pi a^3$
- Evaluate by using Stoke's Theorem $\int_C [\sin z dx - \cos x dy + \sin y dz]$ where C is the boundary of rectangle $0 \leq x \leq \pi, 0 \leq y \leq 1, z = 3$. (AMIETE, June 2010)

GAUSS'S THEOREM OF DIVERGENCE

(Relation between surface integral and volume integral)

(U.P., Ist Semester, Jan., 2011, Dec, 2006)

Statement. The surface integral of the normal component of a vector function F taken around a closed surface S is equal to the integral of the divergence of F taken over the volume V enclosed by the surface S .

Mathematically

$$\iint_S \vec{F} \cdot \hat{n} ds = \iiint_V \text{div } \vec{F} dw$$

Vectors

Proof. Let $\vec{F} = F_1 \hat{i} + F_2 \hat{j} + F_3 \hat{k}$.

Putting the values of \vec{F}, \hat{n} in the statement of the divergence theorem, we have

$$\begin{aligned} \iiint_V (F_1 \hat{i} + F_2 \hat{j} + F_3 \hat{k}) \cdot \hat{n} \, ds &= \iiint_V \left(\hat{i} \frac{\partial}{\partial x} + \hat{j} \frac{\partial}{\partial y} + \hat{k} \frac{\partial}{\partial z} \right) (F_1 \hat{i} + F_2 \hat{j} + F_3 \hat{k}) \, dx \, dy \, dz \\ &= \iiint_V \left(\frac{\partial F_1}{\partial x} + \frac{\partial F_2}{\partial y} + \frac{\partial F_3}{\partial z} \right) \, dx \, dy \, dz \end{aligned} \quad \dots(1)$$

We require to prove (1).

Let us first evaluate $\iiint_V \frac{\partial F_3}{\partial z} \, dx \, dy \, dz$.

$$\begin{aligned} \iiint_V \frac{\partial F_3}{\partial z} \, dx \, dy \, dz &= \iint_R \left[\int_{z=f_1(x,y)}^{z=f_2(x,y)} \frac{\partial F_3}{\partial z} \, dz \right] \, dx \, dy \\ &= \iint_R [F_3(x, y, f_2) - F_3(x, y, f_1)] \, dx \, dy \end{aligned} \quad \dots(2)$$

For the upper part of the surface i.e. S_2 , we have

$$dx \, dy = ds_2 \cos r_2 = \hat{n}_2 \cdot \hat{k} \, ds_2$$

Again for the lower part of the surface i.e. S_1 , we have,

$$dx \, dy = -\cos r_1, \, ds_1 = \hat{n}_1 \cdot \hat{k} \, ds_1$$

$$\iint_R F_3(x, y, f_2) \, dx \, dy = \iint_{S_2} F_3 \hat{n}_2 \cdot \hat{k} \, ds_2$$

and $\iint_R F_3(x, y, f_1) \, dx \, dy = -\iint_{S_1} F_3 \hat{n}_1 \cdot \hat{k} \, ds_1$

Putting these values in (2), we have

$$\iiint_V \frac{\partial F_3}{\partial z} \, dv = \iint_{S_2} F_3 \hat{n}_2 \cdot \hat{k} \, ds_2 + \iint_{S_1} F_3 \hat{n}_1 \cdot \hat{k} \, ds_1 = \iint_S F_3 \hat{n} \cdot \hat{k} \, ds \quad \dots(3)$$

Similarly, it can be shown that

$$\iiint_V \frac{\partial F_2}{\partial y} \, dv = \iint_S F_2 \hat{n} \cdot \hat{j} \, ds \quad \dots(4)$$

$$\iiint_V \frac{\partial F_1}{\partial x} \, dv = \iint_S F_1 \hat{n} \cdot \hat{i} \, ds \quad \dots(5)$$

Adding (3), (4) & (5), we have

$$\begin{aligned} \iiint_V \left(\frac{\partial F_1}{\partial x} + \frac{\partial F_2}{\partial y} + \frac{\partial F_3}{\partial z} \right) \, dv &= \iint_S (F_1 \hat{i} + F_2 \hat{j} + F_3 \hat{k}) \cdot \hat{n} \, ds \\ \Rightarrow \iiint_V (\nabla \cdot \vec{F}) \, dv &= \iint_S \vec{F} \cdot \hat{n} \, ds \quad \text{Proved.} \end{aligned}$$

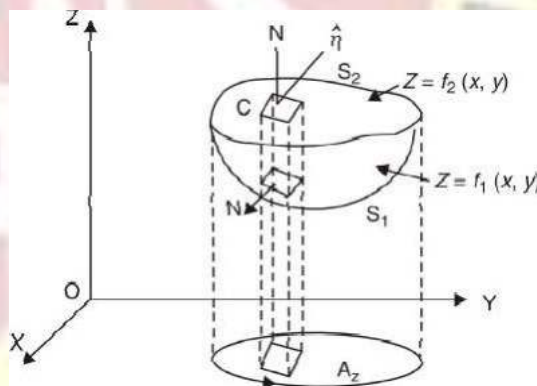

Example 102. State Gauss's Divergence theorem $\iint_S \vec{F} \cdot \hat{n} \, ds = \iiint_V \text{Div } \vec{F} \, dv$ where S is the surface of the sphere $x^2 + y^2 + z^2 = 16$ and $\vec{F} = 3xi + 4y j + 5zk$.
(Nagpur University, Winter 2004)

Solution. Statement of Gauss's Divergence theorem is given in Art 24.8 on page 597.

Thus by Gauss's divergence theorem,

$$\iint_S \vec{F} \cdot \hat{n} \, ds = \iiint_V \nabla \cdot \vec{F} \, dv \quad \text{Here } \vec{F} = 3xi + 4y j + 5zk$$

Vectors

$$\nabla \cdot \vec{F} = \left(\hat{i} \frac{\partial}{\partial x} + \hat{j} \frac{\partial}{\partial y} + \hat{k} \frac{\partial}{\partial z} \right) \cdot (3x\hat{i} + 4y\hat{j} + 5z\hat{k})$$

$$\nabla \cdot \vec{F} = 3 + 4 + 5 = 14$$

Putting the value of $\nabla \cdot \vec{F}$, we get

$$\begin{aligned} \iint_S \vec{F} \cdot \hat{n} \, ds &= \iiint_V 14 \, dv && \text{where } v \text{ is volume of a sphere} \\ &= 14v \\ &= 14 \frac{4}{3} \pi (4)^3 = \frac{3584\pi}{3} \end{aligned} \quad \text{Ans.}$$

Example 103. Evaluate $\iint_S \vec{F} \cdot \hat{n} \, ds$ where $\vec{F} = 4xz\hat{i} - y^2\hat{j} + yz\hat{k}$ and S is the surface of the cube bounded by $x = 0, x = 1, y = 0, y = 1, z = 0, z = 1$.

(U.P., 1st Semester, 2009, Nagpur University, Winter 2003)

Solution. By Divergence theorem,

$$\begin{aligned} \iint_S \vec{F} \cdot \hat{n} \, ds &= \iiint_V (\nabla \cdot \vec{F}) \, dv \\ &= \iiint_V \left(\hat{i} \frac{\partial}{\partial x} + \hat{j} \frac{\partial}{\partial y} + \hat{k} \frac{\partial}{\partial z} \right) \cdot (4xz\hat{i} - y^2\hat{j} + yz\hat{k}) \, dv \\ &= \iiint_V \left[\frac{\partial}{\partial x} (4xz) + \frac{\partial}{\partial y} (-y^2) + \frac{\partial}{\partial z} (yz) \right] dx \, dy \, dz \\ &= \iiint_V (4z - 2y + y) \, dx \, dy \, dz \\ &= \iiint_V (4z - y) \, dx \, dy \, dz = \int_0^1 \int_0^1 \left(\frac{4z^2}{2} - yz \right) dx \, dy \\ &= \int_0^1 \int_0^1 (2z^2 - yz) \, dx \, dy = \int_0^1 \int_0^1 (2 - y) \, dx \, dy \\ &= \int_0^1 \left(2y - \frac{y^2}{2} \right) dy = \frac{3}{2} \int_0^1 dx = \frac{3}{2} [x]_0^1 = \frac{3}{2} (1) = \frac{3}{2} \quad \text{Ans.} \end{aligned}$$

Note: This question is directly solved as on example 14 on Page 574.

Example 104. Find $\iint_S \vec{F} \cdot \hat{n} \, ds$, where $\vec{F} = (2x + 3z)\hat{i} - (xz + y)\hat{j} + (y + 2z)\hat{k}$ and S is the surface of the sphere having centre $(3, -1, 2)$ and radius 3.

(AMIE TE, Dec. 2010, U.P., 1 Semester, Winter 2005, 2000)

Solution. Let V be the volume enclosed by the surface S .

By Divergence theorem, we've

$$\begin{aligned} \iint_S \vec{F} \cdot \hat{n} \, ds &= \iiint_V \text{div } \vec{F} \, dv \\ \text{Now, } \text{div } \vec{F} &= \frac{\partial}{\partial x} (2x + 3z) + \frac{\partial}{\partial y} [-(xz + y)] + \frac{\partial}{\partial z} (y + 2z) = 2 - 1 + 2 = 3 \end{aligned}$$

$$\therefore \iint_S \vec{F} \cdot \hat{n} \, ds = \iiint_V 3 \, dv = 3 \iiint_V dv = 3V.$$

Again V is the volume of a sphere of radius 3. Therefore

$$V = \frac{4}{3} \pi r^3 = \frac{4}{3} \pi (3)^3 = 36\pi.$$

$$\therefore \iint_S \vec{F} \cdot \hat{n} \, ds = 3V = 3 \times 36\pi = 108\pi \quad \text{Ans.}$$

Vectors

Example 105. Use Divergence Theorem to evaluate $\iint_S \vec{A} \cdot d\vec{s}$, where $\vec{A} = x^3 \hat{i} + y^3 \hat{j} + z^3 \hat{k}$ and S is the surface of the sphere $x^2 + y^2 + z^2 = a^2$.

(AMIETE, Dec. 2009)

Solution. $\iint_S \vec{A} \cdot d\vec{s} = \iiint_V \text{div } \vec{A} \, dV$
 $= \iiint_V \left(\hat{i} \frac{\partial}{\partial x} + \hat{j} \frac{\partial}{\partial y} + \hat{k} \frac{\partial}{\partial z} \right) \cdot (x^3 \hat{i} + y^3 \hat{j} + z^3 \hat{k}) \, dV$
 $= \iiint_V (3x^2 + 3y^2 + 3z^2) \, dV = 3 \iiint_V (x^2 + y^2 + z^2) \, dV$
 On putting $x = r \sin \theta \cos \phi$, $y = r \sin \theta \sin \phi$, $z = r \cos \theta$, we get

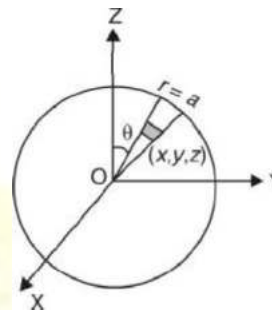

$$= 3 \int_0^\pi \int_0^{2\pi} \int_0^a r^2 (r^2 \sin \theta \, dr \, d\theta \, d\phi) = 3 \times 8 \int_0^\pi \sin \theta \, d\theta \int_0^{2\pi} d\phi \int_0^a r^4 \, dr$$

$$= 24 \left(\frac{\pi}{2} \right) \left(-\cos \theta \right)_0^\pi \left(\frac{r^5}{5} \right)_0^a = 24 \left(\frac{\pi}{2} \right) (-0 + 1) \left(\frac{a^5}{5} \right) = \frac{12\pi a^5}{5}$$

Ans.

Example 106. Use divergence Theorem to show that

$\iint_S \nabla (x^2 + y^2 + z^2) \cdot d\vec{s} = 6V$ where S is any closed surface enclosing volume V . (U.P., I Semester, Winter 2002)

Solution. Here $\nabla (x^2 + y^2 + z^2) = \left(\hat{i} \frac{\partial}{\partial x} + \hat{j} \frac{\partial}{\partial y} + \hat{k} \frac{\partial}{\partial z} \right) \cdot (x^2 + y^2 + z^2)$
 $= 2x \hat{i} + 2y \hat{j} + 2z \hat{k} = 2(x \hat{i} + y \hat{j} + z \hat{k})$

$$\therefore \iint_S \nabla (x^2 + y^2 + z^2) \cdot d\vec{s} = \iint_S \nabla (x^2 + y^2 + z^2) \cdot \hat{n} \, ds$$

\hat{n} being outward drawn unit normal vector to S

$$= \iint_S 2(x \hat{i} + y \hat{j} + z \hat{k}) \cdot \hat{n} \, ds$$

$$= 2 \iiint_V \text{div} (x \hat{i} + y \hat{j} + z \hat{k}) \, dv \quad \dots(1)$$

(By Divergence Theorem)

(V being volume enclosed by S)

Now, $\text{div} (x \hat{i} + y \hat{j} + z \hat{k}) = \left(\hat{i} \frac{\partial}{\partial x} + \hat{j} \frac{\partial}{\partial y} + \hat{k} \frac{\partial}{\partial z} \right) \cdot (x \hat{i} + y \hat{j} + z \hat{k})$
 $= \frac{\partial x}{\partial x} + \frac{\partial y}{\partial y} + \frac{\partial z}{\partial z} = 3 \quad \dots(2)$

From (1) & (2), we have

$$\iint_S \nabla (x^2 + y^2 + z^2) \cdot d\vec{s} = 2 \iiint_V 3 \, dv = 6 \iiint_V dv = 6V \quad \text{Proved.}$$

Example 107. Evaluate $\iint_S (y^2 z^2 \hat{i} + z^2 x^2 \hat{j} + z^2 y^2 \hat{k}) \cdot \hat{n} \, dS$, where S is the part of the sphere $x^2 + y^2 + z^2 = 1$ above the xy -plane and bounded by this plane.

Solution. Let V be the volume enclosed by the surface S . Then by divergence Theorem, we have

$$\iint_S (y^2 z^2 \hat{i} + z^2 x^2 \hat{j} + z^2 y^2 \hat{k}) \cdot \hat{n} \, dS = \iiint_V \text{div} (y^2 z^2 \hat{i} + z^2 x^2 \hat{j} + z^2 y^2 \hat{k}) \, dV$$

$$= \iiint_V \left[\frac{\partial}{\partial x} (y^2 z^2) + \frac{\partial}{\partial y} (z^2 x^2) + \frac{\partial}{\partial z} (z^2 y^2) \right] \, dV = \iiint_V 2z \, y^2 \, dV = 2 \iiint_V z y^2 \, dV$$

Changing to spherical polar coordinates by putting

$$x = r \sin \theta \cos \phi, \quad y = r \sin \theta \sin \phi, \quad z = r \cos \theta, \quad dV = r^2 \sin \theta \, dr \, d\theta \, d\phi$$

To cover V , the limits of r will be 0 to 1, those of θ will be 0 to $\frac{\pi}{2}$ and those of ϕ will be 0 to 2π .

$$\begin{aligned} \therefore \quad 2 \iiint_V zy^2 \, dV &= 2 \int_0^{2\pi} \int_0^{\pi/2} \int_0^1 (r \cos \theta) (r^2 \sin^2 \theta \sin^2 \phi) r^2 \sin \theta \, dr \, d\theta \, d\phi \\ &= 2 \int_0^{2\pi} \int_0^{\pi/2} \int_0^1 r^5 \sin^3 \theta \cos \theta \sin^2 \phi \, dr \, d\theta \, d\phi \\ &= 2 \int_0^{2\pi} \int_0^{\pi/2} \sin^3 \theta \cos \theta \sin^2 \phi \left[\frac{r^6}{6} \right]_0^1 d\theta \, d\phi \\ &= \frac{2}{6} \int_0^{2\pi} \sin^2 \phi \cdot \frac{2}{4 \cdot 2} d\phi = \frac{1}{12} \int_0^{2\pi} \sin^2 \phi \, d\phi = \frac{\pi}{12} \quad \text{Ans.} \end{aligned}$$

Example 108. Use Divergence Theorem to evaluate $\iint_S F \cdot dS$ where $F = 4x\hat{i} - 2y\hat{j} + z\hat{k}$ and S is the surface bounding the region $x^2 + y^2 = 4, z = 0$ and $z = 3$.
(A.M.I.E.T.E., Summer 2003, 2001)

Solution. By Divergence Theorem,

$$\begin{aligned} \iint_S F \cdot dS &= \iiint_V \text{div } F \, dV \\ &= \iiint_V \left(\hat{i} \frac{\partial}{\partial x} + \hat{j} \frac{\partial}{\partial y} + \hat{k} \frac{\partial}{\partial z} \right) \cdot (4x\hat{i} - 2y\hat{j} + z\hat{k}) \, dV \\ &= \iiint_V (4 - 4y + 2z) \, dx \, dy \, dz \\ &= \iint dx \, dy \int_0^3 (4 - 4y + 2z) \, dz = \iint dx \, dy [4z - 4yz + z^2]_0^3 \\ &= \iint (12 - 12y + 9) \, dx \, dy = \iint (21 - 12y) \, dx \, dy \end{aligned}$$

Let us put $x = r \cos \theta, y = r \sin \theta$

$$\begin{aligned} &= \int_0^{2\pi} d\theta \int_0^2 (21 - 12r \sin \theta) r \, dr = \int_0^{2\pi} d\theta \int_0^2 (21r - 12r^2 \sin \theta) \, dr \\ &= \int_0^{2\pi} d\theta \left[\frac{21r^2}{2} - 4r^3 \sin \theta \right]_0^2 = \int_0^{2\pi} d\theta (42 - 32 \sin \theta) = (42\theta + 32 \cos \theta) \Big|_0^{2\pi} \\ &= 84\pi + 32 - 32 = 84\pi \quad \text{Ans.} \end{aligned}$$

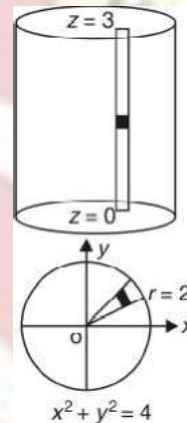

Example 109. Apply the Divergence Theorem to compute $\iint_S u \cdot n \, ds$, where S is the surface of the cylinder $x^2 + y^2 = a^2$ bounded by the planes $z = 0, z = b$ and where $u = \hat{i}x - \hat{j}y + \hat{k}z$.

Solution. By Gauss's Divergence Theorem

$$\begin{aligned} \iint_S u \cdot n \, ds &= \iiint_V (\nabla \cdot u) \, dv \\ &= \iiint_V \left(\hat{i} \frac{\partial}{\partial x} + \hat{j} \frac{\partial}{\partial y} + \hat{k} \frac{\partial}{\partial z} \right) \cdot (\hat{i}x - \hat{j}y + \hat{k}z) \, dv \\ &= \iiint_V \left(\frac{\partial x}{\partial x} - \frac{\partial y}{\partial y} + \frac{\partial z}{\partial z} \right) \, dv = \iiint_V (1 - 1 + 1) \, dv \\ &= \iiint_V dv = \iiint_V dx \, dy \, dz = \text{Volume of the cylinder} = \pi a^2 b \quad \text{Ans.} \end{aligned}$$

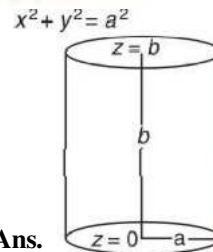

Vectors

Example 110. Apply Divergence Theorem to evaluate $\iiint_V \vec{F} \cdot \hat{n} \, ds$, where

$\vec{F} = 4x^3\hat{i} - x^2y\hat{j} + x^2z\hat{k}$ and S is the surface of the cylinder $x^2 + y^2 = a^2$ bounded by the planes $z = 0$ and $z = b$.
(U.P. Ist Semester, Dec. 2006)

Solution. We have,

$$\begin{aligned} \vec{F} &= 4x^3\hat{i} - x^2y\hat{j} + x^2z\hat{k} \\ \therefore \operatorname{div} \vec{F} &= \left(\hat{i} \frac{\partial}{\partial x} + \hat{j} \frac{\partial}{\partial y} + \hat{k} \frac{\partial}{\partial z} \right) \cdot (4x^3\hat{i} - x^2y\hat{j} + x^2z\hat{k}) \\ &= \frac{\partial}{\partial x} (4x^3) + \frac{\partial}{\partial y} (-x^2y) + \frac{\partial}{\partial z} (x^2z) = 12x^2 - x^2 + x^2 = 12x^2 \\ \text{Now, } \iiint_V \operatorname{div} \vec{F} \, dV &= 12 \int_{x=-a}^a \int_{y=-\sqrt{a^2-x^2}}^{\sqrt{a^2-x^2}} \int_{z=0}^b x^2 \, dz \, dy \, dx \\ &= 12 \int_{x=-a}^a \int_{y=-\sqrt{a^2-x^2}}^{\sqrt{a^2-x^2}} x^2 (z)_0^b \, dy \, dx = 12b \int_{-a}^a x^2 (y)_{-\sqrt{a^2-x^2}}^{\sqrt{a^2-x^2}} \, dx \\ &= 12b \int_{-a}^a x^2 \cdot 2\sqrt{a^2-x^2} \, dx = 24b \int_{-a}^a x^2 \sqrt{a^2-x^2} \, dx \\ &= 48b \int_0^a x^2 \sqrt{a^2-x^2} \, dx \quad [\text{Put } x = a \sin \theta, \, dx = a \cos \theta \, d\theta] \\ &= 48b \int_0^{\pi/2} a^2 \sin^2 \theta \cdot a \cos \theta \cdot a \cos \theta \, d\theta \\ &= 48ba^4 \int_0^{\pi/2} \sin^2 \theta \cdot \cos^2 \theta \, d\theta = 48ba^4 \frac{\frac{3}{2} \frac{3}{2}}{2 \cdot 2} \\ &= 48ba^4 \frac{\frac{1}{\sqrt{\pi}} \cdot \frac{1}{\sqrt{\pi}}}{2 \cdot 2} = 3ba^4\pi \end{aligned}$$

Ans.

Example 111. Evaluate surface integral $\iint_S \vec{F} \cdot \hat{n} \, ds$, where $\vec{F} = (x^2 + y^2 + z^2)(\hat{i} + \hat{j} + \hat{k})$, S is the surface of the tetrahedron $x = 0, y = 0, z = 0, x + y + z = 2$ and n is the unit normal in the outward direction to the closed surface S .

Solution. By Divergence theorem

$$\iint_S \vec{F} \cdot \hat{n} \, ds = \iiint_V \operatorname{div} \vec{F} \, dv$$

where S is the surface of tetrahedron $x = 0, y = 0, z = 0, x + y + z = 2$

$$\begin{aligned} &= \iiint_V \left(\hat{i} \frac{\partial}{\partial x} + \hat{j} \frac{\partial}{\partial y} + \hat{k} \frac{\partial}{\partial z} \right) \cdot (x^2 + y^2 + z^2)(\hat{i} + \hat{j} + \hat{k}) \, dv \\ &= \iiint_V (2x + 2y + 2z) \, dv \\ &= 2 \iiint_V (x + y + z) \, dx \, dy \, dz \\ &= 2 \int_0^2 dx \int_0^{2-x} dy \int_0^{2-x-y} (x + y + z) \, dz \\ &= 2 \int_0^2 dx \int_0^{2-x} dy \left(xz + yz + \frac{z^2}{2} \right)_0^{2-x-y} \end{aligned}$$

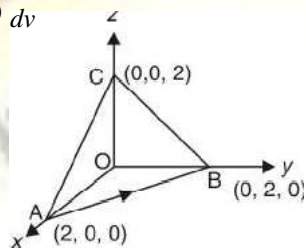

Vectors

$$\begin{aligned}
&= 2 \int_0^2 dx \int_0^{2-x} dy \left[2x^2 - xy + 2y - xy - y + \frac{(2-x-y)^2}{2} \right] \\
&= 2 \int_0^2 dx \left[2xy - x^2y - xy^2 + y^2 - \frac{y^3}{3} - \frac{(2-x-y)^3}{6} \right]_0^{2-x} \\
&= 2 \int_0^2 dx \left[2x(2-x) - x^2(2-x) - x(2-x)^2 + (2-x)^2 - \frac{(2-x)^3}{3} + \frac{(2-x)^3}{6} \right] \\
&= 2 \int_0^2 dx \left[4x - 2x^2 - 2x^2 + x^3 - 4x + 4x^2 - x^3 + (2-x)^2 - \frac{(2-x)^3}{3} + \frac{(2-x)^3}{6} \right] \\
&= 2 \int_0^2 dx \left[2x^2 - \frac{4x^3}{3} + \frac{x^4}{4} - 2x^2 + \frac{4x^3}{3} - \frac{x^4}{4} - \frac{(2-x)^3}{3} + \frac{(2-x)^4}{12} - \frac{(2-x)^4}{24} \right]_0^2 \\
&= 2 \left[-\frac{(2-x)^3}{3} + \frac{(2-x)^4}{12} - \frac{(2-x)^4}{24} \right]_0^2 = 2 \left[\frac{8}{3} - \frac{16}{12} + \frac{16}{24} \right] = 4 \quad \text{Ans.}
\end{aligned}$$

Example 112. Use the Divergence Theorem to evaluate

$\iint_S (x \, dy \, dz + y \, dz \, dx + z \, dx \, dy)$
 where S is the portion of the plane $x + 2y + 3z = 6$ which lies in the first Octant.
 (U.P., I Semester, Winter 2003)

Solution. $\iint_S (f_1 \, dy \, dz + f_2 \, dx \, dz + f_3 \, dx \, dy)$
 $= \iiint_V \left(\frac{\partial f_1}{\partial x} + \frac{\partial f_2}{\partial y} + \frac{\partial f_3}{\partial z} \right) dx \, dy \, dz$

where S is a closed surface bounding a volume V .

$$\begin{aligned}
\therefore \iint_S (x \, dy \, dz + y \, dz \, dx + z \, dx \, dy) &= \iiint_V \left(\frac{\partial x}{\partial x} + \frac{\partial y}{\partial y} + \frac{\partial z}{\partial z} \right) dx \, dy \, dz \\
&= \iiint_V (1 + 1 + 1) \, dx \, dy \, dz = 3 \iiint_V dx \, dy \, dz \\
&= 3 (\text{Volume of tetrahedron } OABC) \\
&= 3 \left[\frac{1}{3} \text{Area of the base } \Delta OAB \times \text{height } OC \right] \\
&= 3 \left[\frac{1}{3} \left(\frac{1}{2} \times 6 \times 3 \right) \times 2 \right] = 18 \quad \text{Ans.}
\end{aligned}$$

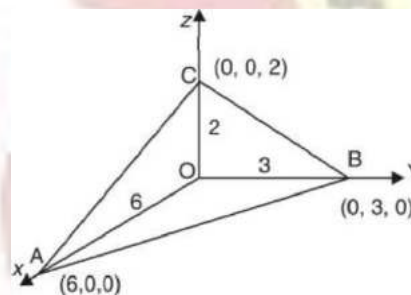

Example 113. Use Divergence Theorem to evaluate : $\iint (x \, dy \, dz + y \, dz \, dx + z \, dx \, dy)$
 over the surface of a sphere radius a . (K. University, Dec. 2009)

Solution. Here, we have

$$\begin{aligned}
&= \iiint_V \left[\frac{\partial x}{\partial x} + \frac{\partial y}{\partial y} + \frac{\partial z}{\partial z} \right] dx \, dy \, dz = \iiint_V \left(\frac{\partial x}{\partial x} + \frac{\partial y}{\partial y} + \frac{\partial z}{\partial z} \right) dx \, dy \, dz \\
&= \iiint_V (1 + 1 + 1) \, dx \, dy \, dz = 3 (\text{volume of the sphere}) \\
&= 3 \left(\frac{4}{3} \pi a^3 \right) = 4 \pi a^3 \quad \text{Ans.}
\end{aligned}$$

Vectors

Example 114. Using the divergence theorem, evaluate the surface integral

$$\iint_S (yz \, dy \, dz + xz \, dx \, dz + xy \, dx \, dy) \text{ where } S : x^2 + y^2 + z^2 = 4.$$

(AMIETE, Dec. 2010, UP, I Sem., Dec 2008)

Solution.
$$\iint_S (f_1 \, dy \, dz + f_2 \, dx \, dz + f_3 \, dx \, dy)$$

$$= \iiint_V \left(\frac{\partial f_1}{\partial x} + \frac{\partial f_2}{\partial y} + \frac{\partial f_3}{\partial z} \right) dx \, dy \, dz$$

where S is closed surface bounding a volume V.

$$\therefore \iint_S (yz \, dy \, dz + xz \, dx \, dz + xy \, dx \, dy)$$

$$= \iiint_V \left(\frac{\partial (yz)}{\partial x} + \frac{\partial (xz)}{\partial y} + \frac{\partial (xy)}{\partial z} \right) dx \, dy \, dz = \iiint_V (0 + 0 + 0) \, dx \, dy \, dz$$

Example 115. Evaluate $\iint_S xz^2 \, dy \, dz + (x^2y - z^3) \, dz \, dx + (2xy + y^2z) \, dx \, dy$

Ans.

where S is the surface of hemispherical region bounded by

$$z = \sqrt{a^2 - x^2 - y^2} \text{ and } z = 0.$$

Solution.
$$\iint_S (f_1 \, dy \, dz + f_2 \, dz \, dx + f_3 \, dx \, dy) = \iiint_V \left(\frac{\partial f_1}{\partial x} + \frac{\partial f_2}{\partial y} + \frac{\partial f_3}{\partial z} \right) dx \, dy \, dz$$

where S is a closed surface bounding a volume V.

$$\therefore \iint_S xz^2 \, dy \, dz + (x^2y - z^3) \, dz \, dx + (2xy + y^2z) \, dx \, dy$$

$$= \iiint_V \left[\frac{\partial}{\partial x} (xz^2) + \frac{\partial}{\partial y} (x^2y - z^3) + \frac{\partial}{\partial z} (2xy + y^2z) \right] dx \, dy \, dz$$

(Here V is the volume of hemisphere)

$$= \iiint_V (z^2 + x^2 + y^2) \, dx \, dy \, dz$$

Let $x = r \sin \theta \cos \phi$, $y = r \sin \theta \sin \phi$, $z = r \cos \theta$

$$= \iiint r^2 (r^2 \sin \theta \, dr \, d\theta \, d\phi) = \int_0^{2\pi} d\phi \int_0^\pi 2 \sin \theta \, d\theta \int_0^a r^4 \, dr$$

$$= \int_0^{2\pi} (-\cos \theta)^{\pi/2} \left(\frac{r^5}{5} \right)_0^a = 2\pi (-0 + 1) \frac{a^5}{5} = \frac{2\pi a^5}{5}$$

Ans.

Example 116. Evaluate $\iint_S F \cdot \hat{n} \, ds$ over the entire surface of the region above the xy-plane

bounded by the cone $z^2 = x^2 + y^2$ and the plane $z = 4$, if $F = 4xz \hat{i} + xyz^2 \hat{j} + 3z \hat{k}$.

Solution. If V is the volume enclosed by S, then V is bounded by the surfaces $z = 0$, $z = 4$, $z^2 = x^2 + y^2$.

By divergence theorem, we have

$$\iint_S F \cdot \hat{n} \, ds = \iiint_V \text{div } F \, dx \, dy \, dz$$

$$= \iiint_V \left[\frac{\partial}{\partial x} (4xz) + \frac{\partial}{\partial y} (xyz^2) + \frac{\partial}{\partial z} (3z) \right] dx \, dy \, dz$$

$$= \iiint_V (4z + xz^2 + 3) \, dx \, dy \, dz$$

Limits of z are $\sqrt{x^2 + y^2}$ and 4.

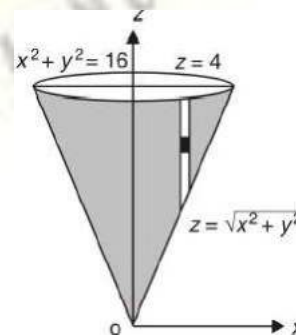

$$\begin{aligned} \iiint_V (4z + xz^2 + 3) dz dy dx &= \iiint_V [2z^2 + xz^3 + 3z]^4 dy dx \\ &= \iiint_V \left(\sqrt{x^2 + y^2} \left(32 + 64x + 12 \right) - \left\{ 2(x^2 + y^2) + x(x^2 + y^2)^{3/2} + 3 \sqrt{x^2 + y^2} \right\} \right) dy dx \\ &= \iiint_V \left(44 + \frac{64x}{\sqrt{x^2 + y^2}} - 2(x^2 + y^2) - x(x^2 + y^2)^{3/2} - 3 \sqrt{x^2 + y^2} \right) dy dx \end{aligned}$$

Putting $x = r \cos \theta$ and $y = r \sin \theta$, we have

$$\begin{aligned} &= \int_0^{2\pi} \int_0^4 \left(44 + \frac{64r \cos \theta}{r} - 2r^2 - r \cos \theta r^3 - 3r \right) r dr d\theta \\ \text{Limits of } r \text{ are } 0 \text{ to } 4, \\ \text{and limits of } \theta \text{ are } 0 \text{ to } 2\pi. \\ &= \int_0^{2\pi} \int_0^4 \left(44r + \frac{64r^2 \cos \theta}{3} - 2r^3 - r^4 \cos \theta - 3r^2 \right) dr d\theta \\ &= \int_0^{2\pi} \left[22r^2 + \frac{64 \times r^3 \cos \theta}{9} - \frac{r^4}{2} - \frac{r^6}{6} \cos \theta - r^3 \right]_0^4 d\theta \\ &= \int_0^{2\pi} \left[22(4)^2 + \frac{64 \times (4)^3 \cos \theta}{9} - \frac{(4)^4}{2} - \frac{(4)^6}{6} \cos \theta - (4)^3 \right] d\theta \\ &= \int_0^{2\pi} \left[352 + \frac{64 \times 64}{9} \cos \theta - 128 - \frac{(4)^6}{6} \cos \theta - 64 \right] d\theta \\ &= \int_0^{2\pi} \left[160 + \left(\frac{64 \times 64}{9} - \frac{(4)^6}{6} \right) \cos \theta \right] d\theta \\ &= \left[160\theta + \left(\frac{64 \times 64}{9} - \frac{(4)^6}{6} \right) \sin \theta \right]_0^{2\pi} = 160(2\pi) + \left(\frac{64 \times 64}{9} - \frac{(4)^6}{6} \right) \sin 2\pi \\ &= 320\pi \end{aligned}$$

Ans.

Example 117. The vector field $\vec{F} = x^2 \hat{i} + z \hat{j} + yz \hat{k}$ is defined over the volume of the cuboid given by $0 \leq x \leq a, 0 \leq y \leq b, 0 \leq z \leq c$, enclosing the surface S . Evaluate the surface integral $\iint_S \vec{F} \cdot d\vec{s}$

(U.P., I Semester, Winter 2001)

Solution. By Divergence Theorem, we have

$$\iint_S (x^2 \hat{i} + z \hat{j} + yz \hat{k}) \cdot d\vec{s} = \iiint_V \text{div} (x^2 \hat{i} + z \hat{j} + yz \hat{k}) dv,$$

where V is the volume of the cuboid enclosing the surface S .

$$\begin{aligned} &= \iiint_V \left(\hat{i} \frac{\partial}{\partial x} + \hat{j} \frac{\partial}{\partial y} + \hat{k} \frac{\partial}{\partial z} \right) \cdot (x^2 \hat{i} + z \hat{j} + yz \hat{k}) dv \\ &= \iiint_V \left\{ \frac{\partial}{\partial x} (x^2) + \frac{\partial}{\partial y} (z) + \frac{\partial}{\partial z} (yz) \right\} dx dy dz \\ &= \int_{x=0}^a \int_{y=0}^b \int_{z=0}^c (2x + y) dx dy dz = \int_0^a dx \int_0^b dy \int_0^c (2x + y) dz \\ &= \int_0^a dx \int_0^b [2xz + yz]_0^c dy = \int_0^a dx \int_0^b (2xc + yc) dy \end{aligned}$$

Vectors

$$\begin{aligned}
 &= c \int_0^a dx \int_0^b (2x + y) dy = c \int_0^a \left[2xy + \frac{y^2}{2} \right]_0^b dx = c \int_0^a \left(2bx + \frac{b^2}{2} \right) dx \\
 &= c \left[\frac{2bx^2}{2} + \frac{b^2x}{2} \right]_0^a = c \left[a^2b + \frac{ab^2}{2} \right] = abc \left(a + \frac{b}{2} \right) \quad \text{Ans.}
 \end{aligned}$$

Example 118. Verify the divergence Theorem for the function $\vec{F} = 2x^2y\hat{i} - y^2\hat{j} + 4xz^2\hat{k}$ taken over the region in the first octant bounded by $y^2 + z^2 = 9$ and $x = 2$.

Solution. $\iiint_V \nabla \cdot \vec{F} dV = \iiint_V \left(i \frac{\partial}{\partial x} + j \frac{\partial}{\partial y} + k \frac{\partial}{\partial z} \right) \cdot (2x^2y\hat{i} - y^2\hat{j} + 4xz^2\hat{k}) dV$

$$\begin{aligned}
 &= \iiint_V (4xy - 2y + 8xz) dx dy dz = \int_0^2 dx \int_0^3 dy \int_0^{\sqrt{9-y^2}} (4xy - 2y + 8xz) dz \\
 &= \int_0^2 dx \int_0^3 dy (4xyz - 2yz + 4xz^2) \Big|_0^{\sqrt{9-y^2}} \\
 &= \int_0^2 dx \int_0^3 [4xy\sqrt{9-y^2} - 2y\sqrt{9-y^2} + 4x(9-y^2)] dy \\
 &= \int_0^2 dx \left[\frac{4x}{2} \frac{2}{3} (9-y^2)^{3/2} + \frac{2}{3} (9-y^2)^{3/2} + 36xy - \frac{4xy^3}{3} \right]_0^3 \\
 &= \int_0^2 (0 + 0 + 108x - 36x + 36x - 18) dx = \int_0^2 (108x - 18) dx = \left[54x^2 - 18x \right]_0^2 \\
 &= 216 - 36 = 180 \quad \dots(1)
 \end{aligned}$$

Here $\iint_S \vec{F} \cdot \hat{n} ds = \iint_{OABC} \vec{F} \cdot \hat{n} ds + \iint_{OCE} \vec{F} \cdot \hat{n} ds + \iint_{OADE} \vec{F} \cdot \hat{n} ds + \iint_{ABD} \vec{F} \cdot \hat{n} ds + \iint_{BDEC} \vec{F} \cdot \hat{n} ds$

$\iint_{BDEC} \vec{F} \cdot \hat{n} ds = \iint_{BDEC} (2x^2y\hat{i} - y^2\hat{j} + 4xz^2\hat{k}) \cdot \hat{n} ds$

Normal vector

$$\begin{aligned}
 &= \nabla\phi = \left(i \frac{\partial}{\partial x} + j \frac{\partial}{\partial y} + k \frac{\partial}{\partial z} \right) (y^2 + z^2 - 9) \\
 &= 2y\hat{j} + 2z\hat{k}
 \end{aligned}$$

Unit normal vector $= \hat{n} = \frac{2y\hat{j} + 2z\hat{k}}{\sqrt{4y^2 + 4z^2}} = \frac{y\hat{j} + z\hat{k}}{\sqrt{y^2 + z^2}}$

$$= \frac{y\hat{j} + z\hat{k}}{\sqrt{9}} = \frac{y\hat{j} + z\hat{k}}{3}$$

$\iint_{BDEC} (2x^2y\hat{i} - y^2\hat{j} + 4xz^2\hat{k}) \cdot \frac{y\hat{j} + z\hat{k}}{3} ds = \frac{1}{3} \iint_{BDEC} (-y^3 + 4xz^3) ds$

$\left[dx dy = ds (\hat{n} \cdot \hat{k}) = ds \left(\frac{y\hat{j} + z\hat{k}}{3} \cdot \hat{k} \right) = ds \frac{z}{3} \text{ or } ds = \frac{3 dx dy}{z} \right]$

$$\begin{aligned}
 &= \frac{1}{3} \iint_{BDEC} (-y^3 + 4xz^3) \frac{3 dx dy}{z} = \int_0^2 dx \int_0^3 \left(-\frac{y^3}{z} + 4xz^2 \right) dy \quad \left(\begin{array}{l} y = 3 \sin \theta \\ z = 3 \cos \theta \end{array} \right) \\
 &= \int_0^2 dx \int_0^{\pi/2} \left[\frac{-27 \sin^3 \theta}{3 \cos \theta} + 4x (9 \cos^2 \theta) \right]
 \end{aligned}$$

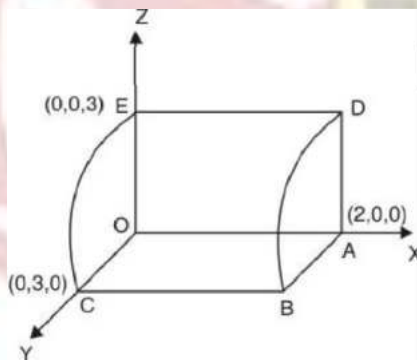

Vectors

$$= \int_0^2 dx \left(\frac{-27 \times 2}{3} + \frac{108 x \times 2}{3} \right) = \int_0^2 (-18 + 72x) dx$$

$$= \left[-18x + 36x^2 \right]_0^2 = 108 \quad \dots(2)$$

$$\iint_{OABC} \vec{F} \cdot \hat{n} \, ds = \iint_{OABC} (2x^2 y \hat{i} - y^2 \hat{j} + 4xz^2 \hat{k}) \cdot (-\hat{k}) \, ds$$

$$= \iint_{OABC} 4xz^2 \, ds = 0 \quad \dots(3) \text{ because in } OABC \text{ } xy\text{-plane, } z = 0$$

$$\iint_{OADE} \vec{F} \cdot \hat{n} \, ds = \iint_{OADE} (2x^2 y \hat{i} - y^2 \hat{j} + 4xz^2 \hat{k}) \cdot (-\hat{j}) \, ds = \iint_{OADE} y^2 \, ds = 0 \quad \dots(4)$$

OADE because in *OADE* *xz*-plane, *y* = 0

$$\iint_{OCE} \vec{F} \cdot \hat{n} \, ds = \iint_{OCE} (2x^2 y \hat{i} - y^2 \hat{j} + 4xz^2 \hat{k}) \cdot (-\hat{i}) \, ds = \iint_{OCE} -2x^2 y \, ds = 0 \quad \dots(5)$$

OCE because in *OCE* *yz*-plane, *x* = 0

$$\iint_{ABD} \vec{F} \cdot \hat{n} \, ds = \iint_{ABD} (2x^2 y \hat{i} - y^2 \hat{j} + 4xz^2 \hat{k}) \cdot (\hat{i}) \, ds = \iint_{ABD} 2x^2 y \, ds$$

$$= \iint 2x^2 y \, dy \, dz = \int_0^3 dz \int_0^{\sqrt{9-z^2}} 2(2)^2 y \, dy \quad \text{because in } ABD \text{ plane, } x = 2$$

$$= 8 \int_0^3 dz \left[\frac{y^2}{2} \right]_0^{\sqrt{9-z^2}} = 4 \int_0^3 dz (9 - z^2) = 4 \left[9z - \frac{z^3}{3} \right]_0^3 = 4 [27 - 9] = 72 \quad \dots(6)$$

On adding (2), (3), (4), (5) and (6), we get

$$\iint_S \vec{F} \cdot \hat{n} \, ds = 108 + 0 + 0 + 0 + 72 = 180 \quad \dots(7)$$

From (1) and (7), we have $\iiint_V \nabla \cdot \vec{F} \, dV = \iint_S \vec{F} \cdot \hat{n} \, ds$
Hence the theorem is verified.

Example 119. Verify the Gauss divergence Theorem for

$\vec{F} = (x^2 - yz) \hat{i} + (y^2 - zx) \hat{j} + (z^2 - xy) \hat{k}$ taken over the rectangular parallelepiped
 $0 \leq x \leq a, 0 \leq y \leq b, 0 \leq z \leq c.$ (U.P., I Semester, Compartment 2002)

Solution. We have

$$\operatorname{div} \vec{F} = \nabla \cdot \vec{F} = \left(\hat{i} \frac{\partial}{\partial x} + \hat{j} \frac{\partial}{\partial y} + \hat{k} \frac{\partial}{\partial z} \right) \cdot [(x^2 - yz) \hat{i} + (y^2 - zx) \hat{j} + (z^2 - xy) \hat{k}]$$

$$= \frac{\partial}{\partial x} (x^2 - yz) + \frac{\partial}{\partial y} (y^2 - zx) + \frac{\partial}{\partial z} (z^2 - xy) = 2x + 2y + 2z$$

$$\therefore \text{Volume integral} = \iiint_V \nabla \cdot \vec{F} \, dV = \iiint_V 2(x + y + z) \, dV$$

$$= 2 \int_{x=0}^a \int_{y=0}^b \int_{z=0}^c (x + y + z) \, dx \, dy \, dz = 2 \int_0^a dx \int_0^b dy \int_0^c (x + y + z) \, dz$$

$$= 2 \int_0^a dx \int_0^b dy \left(xz + yz + \frac{z^2}{2} \right) = 2 \int_0^a dx \int_0^b dy \left(cx + cy + \frac{c^2}{2} \right)$$

$$= 2 \int_0^a dx \left(cxy + c \frac{y^2}{2} + \frac{c^2 y}{2} \right) = 2 \int_0^a dx \left(bcx + \frac{b^2 c}{2} + \frac{bc^2}{2} \right)$$

Vectors

$$= 2 \left[\frac{bcx^2}{2} + \frac{b^2cx}{2} + \frac{bc^2x}{2} \right]_0^a = [a^2bc + ab^2c + abc^2]$$

$$= abc(a + b + c) \quad \dots(A)$$

To evaluate $\iint_S \vec{F} \cdot \hat{n} \, ds$, where S consists of six plane surfaces.

$$\iint_S \vec{F} \cdot \hat{n} \, ds = \iint_{OABC} \vec{F} \cdot \hat{n} \, ds + \iint_{DEFG} \vec{F} \cdot \hat{n} \, ds + \iint_{OAFG} \vec{F} \cdot \hat{n} \, ds$$

$$+ \iint_{BCDE} \vec{F} \cdot \hat{n} \, ds + \iint_{ABEF} \vec{F} \cdot \hat{n} \, ds + \iint_{OCDE} \vec{F} \cdot \hat{n} \, ds$$

$$\iint_{OABC} \vec{F} \cdot \hat{n} \, ds = \iint_{OABC} \{(x^2 - yz)\hat{i} + (y^2 - xz)\hat{j} + (z^2 - xy)\hat{k}\} \cdot (-\hat{k}) \, ds$$

$$= - \int_0^a \int_0^b (z^2 - xy) \, dx \, dy$$

$$= - \int_0^a \int_0^b (0 - xy) \, dx \, dy = \frac{a^2b^2}{4} \quad \dots(1)$$

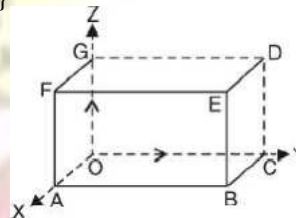

$$\iint_{DEFG} \vec{F} \cdot \hat{n} \, ds = \iint_{DEFG} \{(x^2 - yz)\hat{i} + (y^2 - xz)\hat{j} + (z^2 - xy)\hat{k}\} \cdot (\hat{k}) \, dx \, dy$$

$$= \int_0^a \int_0^b (z^2 - xy) \, dx \, dy = \int_0^a \int_0^b (c^2 - xy) \, dx \, dy$$

$$= \int_0^a \left[c^2y - \frac{xy^2}{2} \right]_0^b \, dx = \int_0^a \left(c^2b - \frac{xb^2}{2} \right) \, dx$$

$$= \left[c^2bx - \frac{x^2b^2}{4} \right]_0^a = abc^2 - \frac{a^2b^2}{4} \quad \dots(2)$$

$$\iint_{OAFG} \vec{F} \cdot \hat{n} \, ds = \iint_{OAFG} \{(x^2 - yz)\hat{i} + (y^2 - xz)\hat{j} + (z^2 - xy)\hat{k}\} \cdot (-\hat{j}) \, dx \, dz$$

$$= - \iint_{OAFG} (y^2 - xz) \, dx \, dz$$

$$= - \int_0^a dx \int_0^c (0 - xz) \, dz = \int_0^a dx \left[\frac{xz^2}{2} \right]_0^c = \int_0^a \frac{xc^2}{2} \, dx = \left[\frac{x^2c^2}{4} \right]_0^a = \frac{a^2c^2}{4} \quad \dots(3)$$

$$\iint_{BCDE} \vec{F} \cdot \hat{n} \, ds = \iint_{BCDE} \{(x^2 - yz)\hat{i} + (y^2 - xz)\hat{j} + (z^2 - xy)\hat{k}\} \cdot \hat{j} \, dx \, dz = \iint_{BCDE} (y^2 - xz) \, dx \, dz$$

$$= - \int_0^a dx \int_0^c (b^2 - xz) \, dz = \int_0^a \left(b^2z - \frac{xz^2}{2} \right) \Big|_0^c \, dx = \int_0^a \left(b^2c - \frac{xc^2}{2} \right) \, dx$$

$$= \left[b^2cx - \frac{x^2c^2}{4} \right]_0^a = ab^2c - \frac{a^2c^2}{4} \quad \dots(4)$$

$$\iint_{ABEF} \vec{F} \cdot \hat{n} \, ds = \iint_{ABEF} \{(x^2 - yz)\hat{i} + (y^2 - xz)\hat{j} + (z^2 - xy)\hat{k}\} \cdot \hat{i} \, dy \, dz$$

$$= \iint_{ABEF} (x^2 - yz) \, dy \, dz = \int_0^a dx \int_0^c \int_0^b (a^2 - yz) \, dy \, dz = \int_0^a dx \left[a^2z - \frac{yz^2}{2} \right]_0^b$$

Vectors

$$= \int_0^b \left(a^2c - \frac{yc^2}{2} \right) dy = \left[a^2cy - \frac{y^2c^2}{4} \right]_0^b = a^2bc - \frac{b^2c^2}{4} \quad \dots(5)$$

$$\begin{aligned} \iint_{OC DG} \vec{F} \cdot \hat{n} \, ds &= \iint_{OC DG} \{ (x^2 - yz)\hat{i} + (y^2 - zx)\hat{j} + (z^2 - xy)\hat{k} \} \cdot (-\hat{i}) \, dy \, dz \\ &= \int_0^b \int_0^c (x^2 - yz) \, dy \, dz = - \int_0^b dy \int_0^c (-yz) \, dz = - \int_0^b dy \left[\frac{-y z^2}{2} \right]_0^c \\ &= \int_0^b \frac{yc^2}{2} \, dy = \left[\frac{y^2 c^2}{4} \right]_0^b = \frac{b^2 c^2}{4} \quad \dots(6) \end{aligned}$$

Adding (1), (2), (3), (4), (5) and (6), we get

$$\begin{aligned} \iint \vec{F} \cdot \hat{n} \, ds &= \left(\frac{a^2 b^2}{4} \right) + \left(\frac{a^2 b^2}{2} \right) + \left(\frac{a^2 c^2}{4} \right) + \left(\frac{a^2 c^2}{2} \right) \\ &\quad + \left(a^2 bc - \frac{b^2 c^2}{4} \right) + \left(\frac{b^2 c^2}{4} \right) + \left(a^2 bc - \frac{b^2 c^2}{4} \right) \\ &= abc^2 + ab^2c + a^2bc \\ &= abc(a + b + c) \quad \dots(B) \end{aligned}$$

From (A) and (B), Gauss divergence Theorem is verified.

Verified.

Example 120. Verify Divergence Theorem, given that $\vec{F} = 4xz\hat{i} - y^2\hat{j} + yz\hat{k}$ and S is the surface of the cube bounded by the planes $x = 0, x = 1, y = 0, y = 1, z = 0, z = 1$.

Solution. $\nabla \cdot \vec{F} = \left(\hat{i} \frac{\partial}{\partial x} + \hat{j} \frac{\partial}{\partial y} + \hat{k} \frac{\partial}{\partial z} \right) \cdot (4xz\hat{i} - y^2\hat{j} + yz\hat{k})$

$$\begin{aligned} &= 4z - 2y + y \\ &= 4z - y \end{aligned}$$

Volume Integral = $\iiint \nabla \cdot \vec{F} \, dv$

$$= \iiint (4z - y) \, dx \, dy \, dz$$

$$= \int_0^1 dx \int_0^1 dy \int_0^1 (4z - y) \, dz$$

$$= \int_0^1 dx \int_0^1 dy (2z^2 - yz) \Big|_0^1 = \int_0^1 dx \int_0^1 dy (2 - y)$$

$$= \int_0^1 dx \left(2y - \frac{y^2}{2} \right) \Big|_0^1 = \int_0^1 dx \left(2 - \frac{1}{2} \right) = \frac{3}{2} \int_0^1 dx = \frac{3}{2} (x) \Big|_0^1 = \frac{3}{2} \quad \dots(1)$$

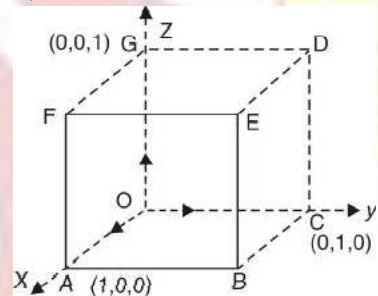

To evaluate $\iint_S \vec{F} \cdot \hat{n} \, ds$, where S consists of six plane surfaces.

Over the face $OABC, z = 0, dz = 0, \hat{n} = -\hat{k}, ds = dx \, dy$

$$\iint \vec{F} \cdot \hat{n} \, ds = \int_0^1 \int_0^1 (-y^2\hat{j}) \cdot (-\hat{k}) \, dx \, dy = 0$$

Over the face $BCDE, y = 1, dy = 0$

Vectors

$$\iint \vec{F} \cdot \hat{n} \, ds = \int_0^1 \int_0^1 (4xz\hat{i} - \hat{j} + z\hat{k}) \cdot (\hat{j}) \, dx \, dz$$

$$\hat{n} = \hat{j}, \, ds = dx \, dz = \int_0^1 \int_0^1 dx \, dz$$

$$= - \int_0^1 dx \int_0^1 dz = -(x)_0^1 (z)_0^1 = -(1)(1) = -1$$

Over the face $DEFG$, $z = 1$, $dz = 0$, $\hat{n} = \hat{k}$, $ds = dx \, dy$

$$\begin{aligned} \iint \vec{F} \cdot \hat{n} \, ds &= \int_0^1 \int_0^1 [4x(1) - y^2\hat{j} + y(1)\hat{k}] \cdot (\hat{k}) \, dx \, dy \\ &= \int_0^1 \int_0^1 y \, dx \, dy = \int_0^1 dx \int_0^1 y \, dy = (x)_0^1 \left(\frac{y^2}{2} \right)_0^1 = \frac{1}{2} \end{aligned}$$

Over the face $OCDG$, $x = 0$, $dx = 0$, $\hat{n} = -\hat{i}$, $ds = dy \, dz$

$$\iint \vec{F} \cdot \hat{n} \, ds = \int_0^1 \int_0^1 (0\hat{i} - y^2\hat{j} + yz\hat{k}) \cdot (-\hat{i}) \, dy \, dz = 0$$

Over the face $AOGF$, $y = 0$, $dy = 0$, $\hat{n} = -\hat{j}$, $ds = dx \, dz$

$$\iint \vec{F} \cdot \hat{n} \, ds = \int_0^1 \int_0^1 (4xz\hat{i}) \cdot (-\hat{j}) \, dx \, dz = 0$$

Over the face $ABEF$, $x = 1$, $dx = 0$, $\hat{n} = \hat{i}$, $ds = dy \, dz$

$$\begin{aligned} \iint \vec{F} \cdot \hat{n} \, ds &= \int_0^1 \int_0^1 [(4z\hat{i} - y^2\hat{j} + yz\hat{k}) \cdot (\hat{i})] \, dy \, dz = \int_0^1 \int_0^1 4z \, dy \, dz \\ &= \int_0^1 dy \int_0^1 4z \, dz = \int_0^1 dy (2z^2)_0^1 = 2 \int_0^1 dy = 2(y)_0^1 = 2 \end{aligned}$$

On adding we see that over the whole surface

$$\iint \vec{F} \cdot \hat{n} \, ds = \left(0 - 1 + \frac{1}{2} + 0 + 0 + 2 \right) = \frac{3}{2} \quad \dots(2)$$

From (1) and (2), we have $\iiint_V \nabla \cdot \vec{F} \, dv = \iint_S \vec{F} \cdot \hat{n} \, ds$

EXERCISE 5.15

1. Use Divergence Theorem to evaluate $\iint_S (y^2z^2\hat{i} + z^2x^2\hat{j} + x^2y^2\hat{k}) \cdot \overline{ds}$,

where S is the upper part of the sphere $x^2 + y^2 + z^2 = 9$ above xy - plane.

$$\text{Ans. } \frac{243\pi}{8}$$

2. Evaluate $\iint_S (\nabla \times \vec{F}) \cdot ds$, where S is the surface of the paraboloid $x^2 + y^2 + z = 4$ above the xy -plane and $\vec{F} = (x^2 + y - 4)\hat{i} + 3xy\hat{j} + (2xz + z^2)\hat{k}$.

$$\text{Ans. } -4\pi$$

3. Evaluate $\iint_S [xz^2 \, dy \, dz + (x^2y - z^3) \, dz \, dx + (2xy + y^2z) \, dx \, dy]$, where S is the surface enclosing a region bounded by hemisphere $x^2 + y^2 + z^2 = 4$ above XY -plane.

4. Verify Divergence Theorem for $\vec{F} = x^2\hat{i} + z\hat{j} + yz\hat{k}$, taken over the cube bounded by $x = 0$, $x = 1$, $y = 0$, $y = 1$, $z = 0$, $z = 1$.

5. Evaluate $\iint_S (2xy\hat{i} + yz^2\hat{j} + xz\hat{k}) \cdot \overline{ds}$ over the surface of the region bounded by

$$x = 0, \, y = 0, \, y = 3, \, z = 0 \text{ and } x + 2z = 6$$

$$\text{Ans. } \frac{351}{2}$$

Verified.

Vectors

6. Verify Divergence Theorem for $\vec{P} = (x + y^2)\hat{i} - 2x\hat{j} + 2yz\hat{k}$ and the volume of a tetrahedron bounded by co-ordinate planes and the plane $2x + y + 2z = 6$.
(Nagpur, Winter 2000, A.M.I.E.T.E., Winter 2000)
7. Verify Divergence Theorem for the function $\vec{F} = y\hat{i} + x\hat{j} + z^2\hat{k}$ over the region bounded by $x^2 + y^2 = 9$, $z = 0$ and $z = 2$.
8. Use the Divergence Theorem to evaluate $\iint_S x^3 dy dz + x^2 y dz dx + x^2 z dx dy$, where S is the surface of the region bounded by the closed cylinder $x^2 + y^2 = a^2$, ($0 \leq z \leq b$) and $z = 0$, $z = b$.
Ans. $\frac{5\pi a^4 b}{4}$
9. Evaluate the integral $\iint_S (z^2 - x) dy dz - xy dx dz + 3z dx dy$, where S is the surface of closed region bounded by $z = 4 - y^2$ and planes $x = 0$, $x = 3$, $z = 0$ by transforming it with the help of Divergence Theorem to a triple integral.
Ans. 16
10. Evaluate $\iint_S \frac{ds}{\sqrt{a^2 x^2 + b^2 y^2 + c^2 z^2}}$ over the closed surface of the ellipsoid $ax^2 + by^2 + cz^2 = 1$ by applying Divergence Theorem.
Ans. $\frac{4\pi}{\sqrt{abc}}$
11. Apply Divergence Theorem to evaluate $\iint_S (l x^2 + m y^2 + n z^2) ds$ taken over the sphere $(x - a)^2 + (y - b)^2 + (z - c)^2 = r^2$, l, m, n being the direction cosines of the external normal to the sphere.
(AMIETE June 2010, 2009) **Ans.** $\frac{8\pi}{3} (a + b + c) r^3$
12. Show that $\iiint_V (u \nabla \cdot \vec{V} + \nabla u \cdot \vec{V}) dv = \iint_S u \vec{V} \cdot \vec{ds}$.
13. If $E = \text{grad } \phi$ and $\nabla^2 \phi = 4\pi\rho$, prove that $\iint_S \vec{E} \cdot \vec{n} ds = -4\pi \iiint_V \rho dv$ where \vec{n} is the outward unit normal vector, while dS and dV are respectively surface and volume elements.
- Pick up the correct option from the following:**
14. If \vec{F} is the velocity of a fluid particle then $\int_C \vec{F} \cdot d\vec{r}$ represents.
(a) Work done (b) Circulation (c) Flux (d) Conservative field.
(U.P. Ist Semester, Dec 2009) **Ans.** (b)
15. If $\vec{f} = ax\vec{i} + by\vec{j} + cz\vec{k}$, a, b, c , constants, then $\iint_S \vec{f} \cdot d\vec{S}$ where S is the surface of a unit sphere is
(a) $\frac{\pi}{3}(a+b+c)$ (b) $\frac{4}{3}\pi(a+b+c)$ (c) $2\pi(a+b+c)$ (d) $\pi(a+b+c)$
(U.P., Ist Semester, 2009) **Ans.** (b)
16. A force field \vec{F} is said to be conservative if
(a) $\text{Curl } \vec{F} = 0$ (b) $\text{grad } \vec{F} = 0$ (c) $\text{Div } \vec{F} = 0$ (d) $\text{Curl } (\text{grad } \vec{F}) = 0$
(AMIETE, Dec. 2006) **Ans.** (a)
17. The line integral $\int_C x^2 dx + y^2 dy$, where C is the boundary of the region $x^2 + y^2 < a^2$ equals
(a) 0, (b) a (c) πa^2 (d) $\frac{1}{2}\pi a^2$
(AMIETE, Dec. 2006) **Ans.** (b)